



- U.S.A. : **KUBOTA TRACTOR CORPORATION**
3401 Del Amo Blvd., Torrance, CA 90503, U.S.A.
Telephone : (310)370-3370
- Western Division : 1175 S. Guild Avc., Lodi, CA 95240
Telephone : (209)334-9910
- Central Division : 14855 FAA Blvd., Fort Worth, TX 76155
Telephone : (817)571-0900
- Northern Division : 6300 at One Kubota Way, Groveport, OH 43125
Telephone : (614)835-1100
- Southeast Division : 1025 Northbrook Parkway, Suwanee, GA 30024
Telephone : (770)995-8855
- Canada : **KUBOTA CANADA LTD.**
5900 14th Avenue, Markham, Ontario, L3S 4K4, Canada
Telephone : (905)294-7477
- France : **KUBOTA EUROPE S.A.S**
19-25, Rue Jules Vercey, Z.I. BP88, 95101 Argenteuil Cedex, France
Telephone : (33)1-3426-3434
- Italy : **KUBOTA EUROPE S.A.S Italy Branch**
Via Grandi, 29 20068 Peschiera Borrome (MI) Italy
Telephone : (39)02-51650377
- Germany : **KUBOTA (DEUTSCHLAND) GmbH**
Senefelder Str. 3-5 63110 Rodgau /Nieder-Roden, Germany
Telephone : (49)6106-873-0
- U.K. : **KUBOTA (U.K.) LTD.**
Dormer Road, Thame, Oxfordshire, OX9 3UN, U.K.
Telephone : (44)1844-214500
- Spain : **KUBOTA ESPAÑA S.A.**
Avenida Recomba No.5, Poligno Industrial la Laguna, Leganes, 28914 (Madrid) Spain
Telephone : (34)91-508-6442
- Australia : **KUBOTA TRACTOR AUSTRALIA PTY LTD.**
25-29 Permas Way, Truganina, VIC 3029, Australia
Telephone : (61)-3-9394-4400
- Malaysia : **SIME KUBOTA SDN. BHD.**
No.3 Jalan Sepadu 25/123 Taman Perindustrian Axis,
Seksyen 25, 40400 Shah Alam, Selangor Darul Ehsan Malasia
Telephone : (60)3-736-1388
- Philippines : **KUBOTA PHILIPPINES, INC.**
155 Panay Avenue, South Triangle Homes, 1103 Quezon City, Philippines
Telephone : (63)2-9201071
- Taiwan : **SHIN TAIWAN AGRICULTURAL MACHINERY CO., LTD.**
16, Fengping 2nd Rd, Taliaw Shiang Kaohsiung 83107, Taiwan R.O.C.
Telephone : (886)7-702-2333
- Indonesia : **P.T. KUBOTA INDONESIA**
JALAN. Setyabudi 279, Semarang, Indonesia
Telephone : (62)-24-7472849
- Thailand : **SIAM KUBOTA CORPORATION CO., LTD.**
101/19-24 Moo 20, Navanakorn Industrial Estate, Tambon Khlongnueng, Amphur Khlongluang,
Pathumthani 12120, THAILAND
Telephone : (66)2-909-0300
- Korea : **KUBOTA KOREA CO., LTD.**
106-24 Mongsan-Ri, Mankyung-Up, Kimje-City, Chonrapuk-Do, KOREA
Telephone : (82)-63-544-5822
- India : **KUBOTA AGRICULTURAL MACHINERY INDIA PVT. LTD.**
Regus, Level 2 Altius, Olympia Tech Park, No.1 SIDCO Industrial Estate, Guindy, Chennai 600032, TN, India
Telephone : (91)-44-4299-4237
- Vietnam : **KUBOTA VIETNAM CO., LTD.**
Lot B-3A2-CN, My Phuoc 3 Industrial Park, Ben Cat District, Binh Duong Province, Vietnam
Telephone : (84)-650-3577-507

KUBOTA Corporation

English (U.S.A.)
Code No. 3C782-9971-2

OPERATOR'S MANUAL

KUBOTA TRACTOR

MODELS **M8540**
M9540



1AGAIDGAP001A

M
8
5
4
0
·
M
9
5
4
0

READ AND SAVE THIS MANUAL



ABBREVIATION LIST

Abbreviations	Definitions
2WD	Two Wheel Drive
4WD	Four Wheel Drive
API	American Petroleum Institute
ASABE	American Society of Agricultural and Biological Engineers, USA
ASTM	American Society for Testing and Materials, USA
DIN	Deutsches Institut für Normung, GERMANY
DT	Dual Traction [4WD]
fpm	Feet Per Minute
GST	Glide Shift Transmission
Hi-Lo	High Speed-Low Speed
HST	Hydrostatic Transmission
m/s	Meters Per Second
PTO	Power Take Off
RH/LH	Right-hand and left-hand sides are determined by facing in the direction of forward travel
ROPS	Roll-Over Protective Structures
rpm	Revolutions Per Minute
r/s	Revolutions Per Second
SAE	Society of Automotive Engineers, USA
SMV	Slow Moving Vehicle

California Proposition 65

⚠ WARNING ⚠

Engine exhaust, some of its constituents, certain vehicle components and fluids, contain or emit chemicals known to the State of California to cause cancer and birth defects or other reproductive harm.

IMPORTANT

The engine in this machine is not equipped by the manufacturer with a standard spark arrester. It is a violation of California Public Resource Code Section 4442 to use or operate this engine on or near any forest-covered, brush-covered land, or grass-covered land unless the exhaust system is equipped with a working spark arrester meeting state laws. Other states or federal areas may have similar laws.

KUBOTA Corporation is ...

Since its inception in 1890, KUBOTA Corporation has grown to rank as one of the major firms in Japan.

To achieve this status, the company has through the years diversified the range of its products and services to a remarkable extent. Nineteen plants and 16,000 employees produce over 1,000 different items, large and small.













































All these products and all the services which accompany them, however, are unified by one central commitment. KUBOTA makes products which, taken on a national scale, are basic necessities. Products which are indispensable. Products which are intended to help individuals and nations fulfill the potential inherent in their environment. KUBOTA is the Basic Necessities Giant.

This potential includes water supply, food from the soil and from the sea, industrial development, architecture and construction, and transportation.

Thousands of people depend on KUBOTA's know-how, technology, experience and customer service. You too can depend on KUBOTA.

UNIVERSAL SYMBOLS

As a guide to the operation of your tractor, various universal symbols have been utilized on the instruments and controls. The symbols are shown below with an indication of their meaning.

	Safety Alert Symbol		Draft Control-Shallow Position
	Diesel Fuel		Draft Control-Deep Position
	Fuel-Level		3-Point Lowering Speed Control
	Engine-Rotational Speed		Remote Cylinder-Retract
	Hourmeter/Elapsed Operating Hours		Remote Cylinder-Extend
	Engine Coolant-Temperature		Hazard Warning Lights
	Diesel Preheat/Glow Plugs(Low Temperature Start Aid)		Headlight-Low Beam
	Parking Brake		Headlight-High Beam
	Engine Intake/Combustion Air-Filter		Four-Wheel Drive-On
	Battery Charging Condition		Four-Wheel Drive-Off
	Engine Oil-Pressure		Front-Wheel Drive-On
	Turn Signal		Fast
	Electrical Power-accessories		Slow
	Engine-Run		Creep
	Engine-Start		Windshield Wiper
	Engine-Stop		Windshield Wiper Intermittent
	Power Take-Off Clutch Control-Off (Disengaged) Position		Windshield Washer
	Power Take-Off Clutch Control-On (Engaged) Position		Lock
	Bi-Speed turn		Rear Window Defroster
	Differential Lock		Steering Wheel-Tilt Control
	Position Control-Raised Position		Empty
	Position Control-Lowered Position		Full
			PTO 540 rpm
			PTO 1000 rpm

FOREWORD

You are now the proud owner of a KUBOTA Tractor. This tractor is a product of KUBOTA quality engineering and manufacturing. It is made of fine materials and under a rigid quality control system. It will give you long, satisfactory service. To obtain the best use of your tractor, please read this manual carefully. It will help you become familiar with the operation of the tractor and contains many helpful hints about tractor maintenance. It is KUBOTA's policy to utilize as quickly as possible every advance in our research. The immediate use of new techniques in the manufacture of products may cause some small parts of this manual to be outdated. KUBOTA distributors and dealers will have the most up-to-date information. Please do not hesitate to consult with them.



SAFETY FIRST

This symbol, the industry's "Safety Alert Symbol", is used throughout this manual and on labels on the machine itself to warn of the possibility of personal injury. Read these instructions carefully. It is essential that you read the instructions and safety regulations before you attempt to assemble or use this unit.



DANGER : Indicates an imminently hazardous situation which, if not avoided, will result in death or serious injury.



WARNING : Indicates a potentially hazardous situation which, if not avoided, could result in death or serious injury.



CAUTION : Indicates a potentially hazardous situation which, if not avoided, may result in minor or moderate injury.

IMPORTANT : Indicates that equipment or property damage could result if instructions are not followed.

NOTE : Gives helpful information.

CONTENTS

- ▲ SAFE OPERATION ▲ -1
- SERVICING OF TRACTOR..... 1
- SPECIFICATIONS..... 2
 - SPECIFICATION TABLE 2
 - TRAVELING SPEEDS 4
- IMPLEMENT LIMITATIONS 6
- INSTRUMENT PANEL AND CONTROLS..... 8
- PRE-OPERATION CHECK 12
 - DAILY CHECK 12
- OPERATING THE ENGINE..... 13
 - STARTING THE ENGINE 13
 - COLD WEATHER STARTING 17
 - Block Heater (if equipped) 17
 - STOPPING THE ENGINE..... 17
 - WARMING UP 17
 - Warm-up and Transmission Oil at Low Temperature Range 17
 - JUMP STARTING 18
- OPERATING THE TRACTOR..... 19
 - OPERATING NEW TRACTOR 19
 - Do not Operate the Tractor at Full Speed for the First 50 Hours..... 19
 - Changing Lubricating Oil for New Tractors..... 19
 - STARTING 19
 - Operator's Seat..... 19
 - Seat Belt 20
 - Tilt Steering Adjustment..... 21
 - Light Switch 21
 - Turn Signal / Hazard Light Switch 21
 - Horn Button..... 22
 - Brake Pedals (Right and Left)..... 22
 - Clutch Pedal 24
 - Main Gear Shift Lever..... 25
 - Range Gear Shift Lever 25
 - Hydraulic-Shuttle Shift Lever 25
 - Main Gear Shift Lever..... 26
 - Range Gear Shift Lever 26
 - Synchro-Shuttle Shift Lever 26
 - Main Gear Shift Lever..... 27
 - Range Gear Shift Lever 27
 - Hydraulic-Shuttle Shift Lever 27
 - Dual Speed Shift Switch 28
 - Creep Speed (if equipped)..... 28
 - Front Wheel Drive Lever..... 29
 - 4WD Switch 30

Hand Throttle Lever	31
Foot Throttle	31
Parking Brake Lever	31
STOPPING.....	31
Stopping.....	31
CHECK DURING DRIVING	32
Immediately Stop the Engine if:	32
Easy Checker(TM).....	32
Fuel Gauge	32
Coolant Temperature Gauge	33
Tachometer.....	33
PTO RPM / TRAVEL SPEED MONITOR.....	34
Changing Display Mode.....	34
PTO Speed Display Mode Switching.....	36
Entering the Travel Speed Coefficient.....	37
PARKING	38
Parking.....	38
OPERATING TECHNIQUES	39
Differential Lock.....	39
Operating the Tractor on a Road	39
Operating on Slopes and Rough Terrain.....	40
Directions for Use of Power Steering.....	40
Trailer Electrical Outlet	40
PTO	41
PTO OPERATION.....	41
PTO Clutch Control Lever.....	41
PTO Clutch Control Switch.....	42
1000 rpm PTO Shaft.....	43
LCD Monitor Message.....	43
PTO Shaft Cover and Shaft Cap	44
THREE-POINT HITCH & DRAWBAR.....	45
3-POINT HITCH.....	46
Selecting the holes of Lower Links	46
Adjusting Lateral Float.....	46
Selecting the Top Link Mounting Holes	46
Drawbar	46
Lifting Rod (Left).....	47
Lifting Rod (Right).....	47
Top Link.....	48
Telescopic Stabilizers	48
Telescopic Lower Links	49
DRAWBAR.....	49
Adjusting Drawbar Length	49
Swing Drawbar	49
HYDRAULIC UNIT.....	50
3-POINT HITCH CONTROL SYSTEM.....	50
Position Control	50
Draft Control	50
Mixed Control.....	50
Float Control	51

3-point Hitch Lowering Speed.....	51
REMOTE HYDRAULIC CONTROL SYSTEM.....	51
Remote Control Valve.....	51
Remote Control Valve Lever.....	52
Remote Control Valve Coupler Connecting and Disconnecting	52
Flow Control Valve (option)	53
Adjusting the flow rate	53
Positions and advantages of the flow control valve.....	54
Hydraulic Control Unit Use Reference Chart.....	55
TIRES, WHEELS AND BALLAST.....	56
TIRES.....	56
Inflation Pressure.....	56
Dual Tires	56
WHEEL ADJUSTMENT	56
Front Wheels (with two wheel drive).....	56
Front Wheels (with four wheel drive)	57
Rear Wheels	58
BALLAST	59
Front Ballast.....	59
Rear Ballast	59
CAB OPERATION	61
DOOR AND WINDOW	61
Locking and Unlocking the Door.....	61
Opening the Door	61
Rear Window	62
Side Window.....	62
DOME LIGHT	62
Dome Light	62
WORK LIGHT	63
Work Light Switch.....	63
Front Work Light	63
Rear Work Light.....	63
WIPER	64
Front Wiper / Washer Switch	64
Rear Wiper / Washer Switch (if equipped).....	64
Using the Wipers in Cold Season	64
AIR CONDITIONER.....	65
Airflow	65
Air Control Vent	65
Control Panel.....	66
Operation.....	67
REAR / SIDE DEFOGGER WITH TIMER (if equipped).....	69
CIGARETTE LIGHTER.....	69
INSTALLING THE IMPLEMENT CONTROL BOX.....	69
Electrical Outlet.....	69
MAINTENANCE.....	70
SERVICE INTERVALS	70
LUBRICANTS	73
PERIODIC SERVICE.....	75

HOW TO OPEN THE HOOD	75
Hood	75
DAILY CHECK	76
Walk Around Inspection.....	76
Checking and Refueling.....	76
Checking Water Separator	76
Checking Engine Oil Level.....	77
Checking Transmission Fluid Level.....	77
Checking Coolant Level.....	78
Cleaning Evacuator Valve	78
Cleaning Grill, Radiator Screen, Oil Cooler and Battery Mount.....	78
Cleaning Air Conditioner Condenser Screen.....	80
Checking Dust Indicator.....	80
Checking Brake Pedal	80
Checking Brake Pedals and Clutch Pedal	81
Checking Gauges, Meter and Easy Checker(TM).....	81
Checking Head Light, Hazard Light etc.	81
Checking Seat Belt	81
EVERY 50 HOURS	81
Checking Engine Start System	81
Checking Wheel Bolt Torque.....	82
EVERY 100 HOURS	83
Checking Battery Condition	83
Cleaning Air Cleaner Primary Element.....	85
Adjusting Fan Belt Tension.....	85
Adjusting Clutch Pedal.....	86
Adjusting Brake Pedal	86
Checking Parking Brake Lever	87
Checking Fuel Line.....	87
Lubricating Grease Fittings.....	88
EVERY 200 HOURS	89
Checking Radiator Hose and Clamp	89
Checking Intake Air Line.....	90
Checking Power Steering Line	90
Adjusting Toe-in.....	90
Draining Fuel Tank Water.....	91
Cleaning Inner Air Filter.....	91
Cleaning Fresh Air Filter	92
Checking Air Conditioner Condenser	93
Adjusting Air-Conditioner Belt Tension	93
EVERY 300 HOURS	94
Replacing Hydraulic Oil Filter	94
Changing Engine Oil.....	95
EVERY 400 HOURS	95
Replacing Fuel Filter.....	95
Cleaning Water Separator	96
Lubricating Grease Fitting [2WD Model].....	96
EVERY 600 HOURS	97
Replacing Engine Oil Filter	97
Changing Transmission Fluid	97
Changing Front Differential Case Oil	98
Changing Front Axle Gear Case Oil	99

Adjusting Front Axle Pivot.....	99
EVERY 800 HOURS	99
Adjusting Engine Valve Clearance	99
EVERY 1500 HOURS	99
Checking Fuel Injection Nozzle (Injection Pressure)	99
EVERY 3000 HOURS	99
Checking Turbocharger	99
Checking Injection Pump	99
Checking Intake Air Heater	99
EVERY 1 YEAR	99
Replacing Air Cleaner Primary Element and Secondary Element.....	99
Checking Air-Conditioner Pipe and Hose	99
Checking CAB Isolation Cushion.....	99
EVERY 2 YEARS.....	100
Flushing Cooling System and Changing Coolant	100
Anti-Freeze	101
Replacing Radiator Hose (Water pipes)	102
Cleaning Master Cylinder Filter	102
Replacing Power Steering Hose.....	102
Replacing Fuel Hose	102
Replacing Intake Air Line.....	102
Replacing Lift Cylinder Hose	102
Replacing Master Cylinder Kit	102
Replacing Equalizer Kit.....	102
Replacing Brake Seal 1 and 2	102
Replacing Air Conditioner Hose.....	102
SERVICE AS REQUIRED.....	102
Bleeding Fuel System.....	102
Bleeding Brake System	103
Draining Clutch Housing Water	103
Replacing Fuse.....	103
Replacing Light Bulb.....	105
Replacing Head Lamp	106
Lubricating Points	106
Adding Washer Liquid.....	106
Checking the Amount of Refrigerant (gas)	106
STORAGE	108
TRACTOR STORAGE	108
REMOVING THE TRACTOR FROM STORAGE.....	108
TROUBLESHOOTING.....	109
ENGINE TROUBLESHOOTING	109
OPTIONS.....	110
MOUNTING THE SUPPORT PLATE.....	110
Installation Procedures	110



SAFE OPERATION

Careful operation is your best insurance against an accident.

Read and understand this manual carefully before operating the tractor.

All operators, no matter how much experience they may have, should read this and other related manuals before operating the tractor or any implement attached to it. It is the owner's obligation to instruct all operators in safe operation.

1. BEFORE OPERATING THE TRACTOR

1. Know your equipment and its limitations. Read this entire manual before attempting to start and operate the tractor.
2. Pay special attention to the danger, warning and caution labels on the tractor.
3. KUBOTA recommends the use of a CAB or Roll Over Protective Structures (ROPS) and seat belt in almost all applications. This combination will reduce the risk of serious injury or death, should the tractor be upset. If the CAB or ROPS is loosened or removed for any reason, make sure that all parts are reinstalled correctly before operating the tractor.
Never modify or repair a CAB or ROPS because welding, bending, drilling, grinding, or cutting may weaken the structure.
A damaged CAB or ROPS structure must be replaced, not repaired or revised. If any structural member of the CAB or ROPS is damaged, replace the entire structure at your local KUBOTA Dealer.

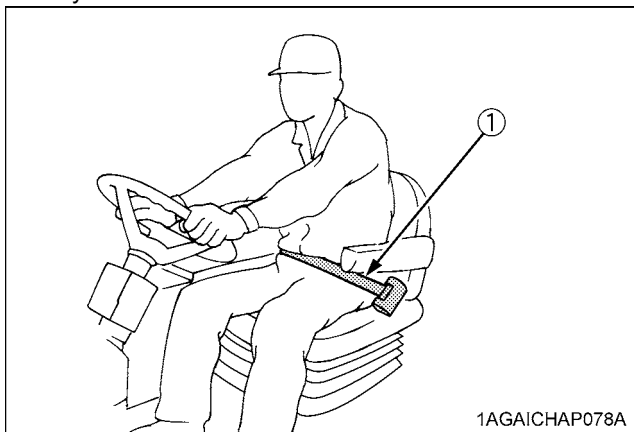

(1) Seat belt

4. Always use the seat belt if the tractor has a CAB or ROPS. Do not use the seat belt if there is no CAB or ROPS. Check the seat belt regularly and replace if frayed or damaged.

5. Do not operate tractor or any implement attached to it while under the influence of alcohol, medication, controlled substances or while fatigued.
6. Carefully check the vicinity before operating tractor or any implement attached to it. Check for overhead clearance which may interfere with a CAB or ROPS. Do not allow any bystanders around or near tractor during operation.
7. Before allowing other people to use your tractor, explain how to operate and have them read this manual before operation.
8. Never wear loose, torn, or bulky clothing around tractor. It may catch on moving parts or controls, leading to the risk of an accident. Use additional safety items, e.g. hard hat, safety boots or shoes, eye and hearing protection, gloves, etc., as appropriate or required.
9. Do not allow passengers to ride on any part of the tractor at anytime. The operator must remain in the tractor seat during operation.
10. Check brakes, clutch, linkage pins and other mechanical parts for improper adjustment and wear. Replace worn or damaged parts promptly. Check the tightness of all nuts and bolts regularly. (For further details, see "MAINTENANCE" section.)
11. Keep your tractor clean. Dirt, grease, and trash build up may contribute to fires and lead to personal injury.
12. Use only implements meeting the specifications listed under "IMPLEMENT LIMITATIONS" in this manual or implements approved by KUBOTA.
13. Use proper weights on the front or rear of the tractor to reduce the risk of upsets. When using the front loader, put an implement or ballast on the 3-point hitch to improve stability. Follow the safe operating procedures specified in the implement or attachment manual.

▲-2 SAFE OPERATION

14. The narrower the tread, the greater the risk of a tractor upset. For maximum stability, adjust the wheels to the widest practical tread width for your application. (See "TIRES, WHEELS AND BALLAST" section.)

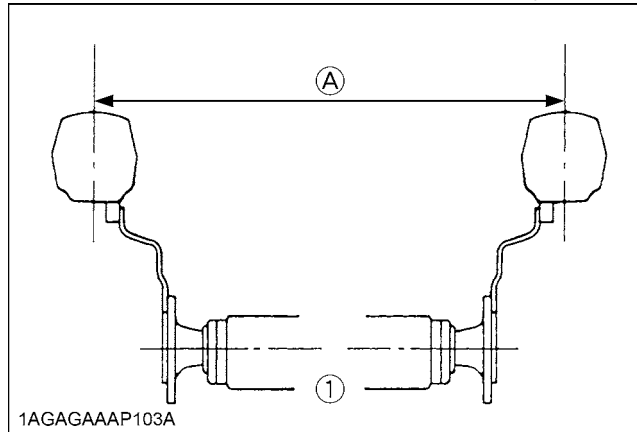

(1) Rear wheels (A) Tread Width

15. Do not modify the tractor. Unauthorized modification may affect the function of the tractor, which may result in personal injury.

2. OPERATING THE TRACTOR

Operator safety is a priority. Safe operation, specifically with respect to overturning hazards, entails understanding the equipment and environmental conditions at the time of use. Some prohibited uses which can affect overturning hazards include traveling and turning with implements and loads carried too high etc. This manual sets forth some of the obvious risks, but the list is not, and cannot be, exhaustive. It is the operator's responsibility to be alert for any equipment or environmental condition that could compromise safe operation.

◆ Starting

1. Always sit in the operator's seat when starting engine or operating levers or controls. Adjust seat per instructions in the operating the tractor section. Never start engine while standing on the ground.
2. Before starting the engine, make sure that all levers (including auxiliary control levers) are in their neutral positions, that the parking brake is engaged, and that both the clutch and the Power Take-Off (PTO) are disengaged or "OFF".
Fasten the seat belt if the tractor has a CAB, a fixed ROPS or a foldable ROPS in the upright and locked position.
3. Do not start engine by shorting across starter terminals or bypassing the safety start switch. Machine may start in gear and move if normal starting circuitry is bypassed.
4. Do not operate or idle engine in a non-ventilated area. Carbon monoxide gas is colorless, odorless, and deadly.

5. Check before each use that operator presence controls are functioning correctly. Test safety systems. (See "Checking Engine Start System" in "EVERY 50 HOURS" in "PERIODIC SERVICE" section.)
Do not operate unless they are functioning correctly.

◆ Working

1. Pull only from the drawbar. Never hitch to axle housing or any other point except drawbar; such arrangements will increase the risk of serious personal injury or death due to a tractor upset.

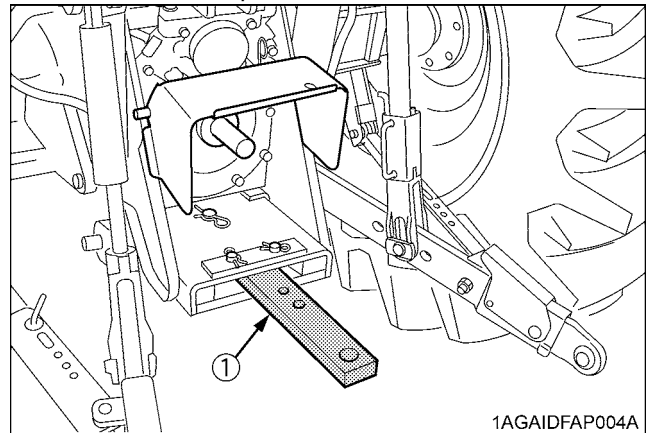

(1) Drawbar

2. Keep all shields and guards in place. Replace any that are missing or damaged.
3. Avoid sudden starts. To avoid upsets, slow down when turning, on uneven ground, and before stopping.
4. The tractor cannot turn with the rear wheel or 4-wheel differential locked and attempting to do so could be dangerous.
5. Do not operate near ditches, holes, embankments, or other ground surface features which may collapse under the tractor's weight. The risk of tractor upset is even higher when the ground is loose or wet. Tall grass can hide obstacles, walk the area first to be sure.
6. Watch where you are going at all times. Watch for and avoid obstacles. Be alert at row ends, near trees, and other obstructions.
7. When working in groups, always let the others know what you are going to do before you do it.
8. Never try to get on or off a moving tractor.
9. Do not stand between tractor and implement or trailed vehicle unless parking brake is applied.

◆ Safety for children

Tragedy can occur if the operator is not alert to the presence of children. Children generally are attracted to machines and the work they do.

1. Never assume that children will remain where you last saw them.
2. Keep children out of the work area and under the watchful eye of another responsible adult.
3. Be alert and shut your machine down if children enter the work area.

4. Never carry children on your machine. There is no safe place for them to ride. They may fall off and be run over or interfere with your control of the machine.
5. Never allow children to operate the machine even under adult supervision.
6. Never allow children to play on the machine or on the implement.
7. Use extra caution when backing up. Look behind and down to make sure area is clear before moving.
8. When parking your machine if at all possible park on a firm, flat and level surface; if not, park across a slope. Set the parking brake(s), lower the implements to the ground, remove the key from the ignition and lock the cab door (if equipped) and chock the wheels.

◆ Operating on slopes

Slopes are major factor related to loss-of-control and tip-over accidents, which can result in severe injury or death. All slopes require extra caution.

1. To avoid upsets, always back up steep slopes. If you cannot back up the slope or if you feel uneasy on it, do not operate on it. Stay off slopes too steep for safe operation.
2. Driving forward out of a ditch, mired condition or up a steep slope increases the risk of a tractor to be upset backward. Always back out of these situations. Extra caution is required with four-wheel drive models because their increased traction can give the operator false confidence in the tractor's ability to climb slopes.
3. Keep all movement on slopes slow and gradual. Do not make sudden changes in speed, direction or apply brake and make sudden motions of the steering wheel.
4. Avoid disengaging the clutch or changing gears speed when climbing or going down a slope. If on a slope disengaging the clutch or changing gears to neutral could cause loss of control.
5. Special attention should be made to the weight and location of implements and loads as such will affect the stability of the tractor.
6. To improve stability on slope, set widest wheel tread as shown in "TIRES, WHEELS AND BALLAST" section.

Follow recommendations for proper ballasting.

◆ Driving the tractor on the road

1. Lock the two brake pedals together to help assure straight-line stops. Uneven braking at road speeds could cause the tractor to tip over.

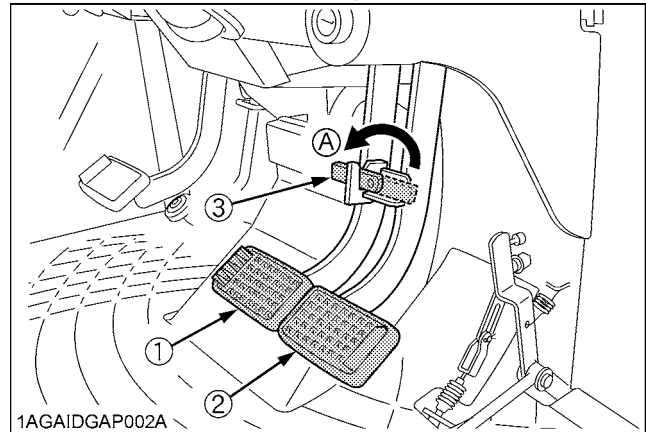

- (1) Brake Pedal (LH) (A) Whenever travelling on the road
 (2) Brake Pedal (RH)
 (3) Brake Pedal Lock

2. Check the front wheel engagement. The braking characteristics are different between two and four wheel drive. Be aware of the difference and use carefully.
3. Always slow the tractor down before turning. Turning at high speed may tip the tractor over.
4. Make sure that the Slow Moving Vehicle (SMV) sign is clean and visible. Use hazard lights and turn signals as required.

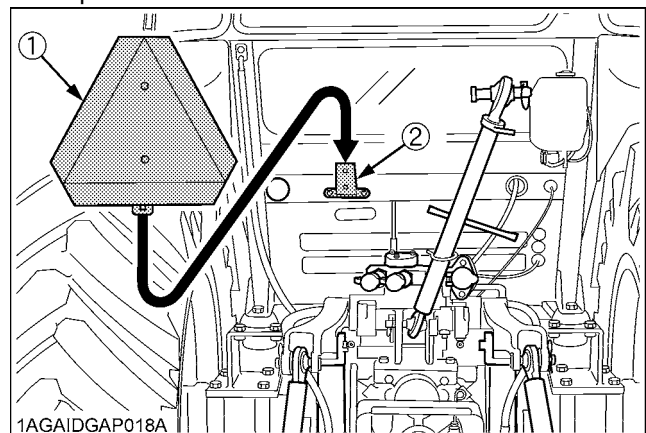

- (1) SMV emblem
 (2) Bracket

5. Observe all local traffic and safety regulations.
6. Turn the headlights on. Dim them when meeting another vehicle.
7. Drive at speeds that allow you to maintain control at all times.
8. Do not apply the differential lock while traveling at road speeds. The tractor may run out of control.

▲-4 SAFE OPERATION

9. Avoid sudden motions of the steering wheel as they can lead to a dangerous loss of stability. The risk is especially great when the tractor is traveling at road speeds.
10. Do not operate an implement while the tractor is on the road. Lock the 3-point hitch in the raised position.
11. When towing other equipment, use a safety chain and place an SMV emblem on it as well.

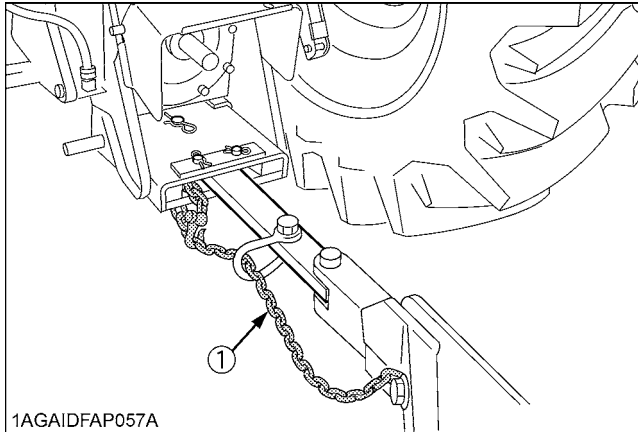

(1) Safety chain

3. PARKING THE TRACTOR

1. Disengage the PTO, lower all implements to the ground, place all control levers in their neutral positions, set the parking brake, stop the engine, and remove the key.
2. Make sure that the tractor has come to a complete stop before dismounting.
3. Avoid parking on steep slopes, if at all possible park on a firm and level surface; if not, park across a slope with chock the wheels.
Failure to comply with this warning may allow the tractor to move and could cause injury or death.

4. OPERATING THE PTO

1. Wait until all moving components have completely stopped before getting off the tractor, connecting, disconnecting, adjusting, cleaning, or servicing any PTO driven equipment.

2. Keep the PTO shaft cover in place at all times. Replace the PTO shaft cap when the shaft is not in use.

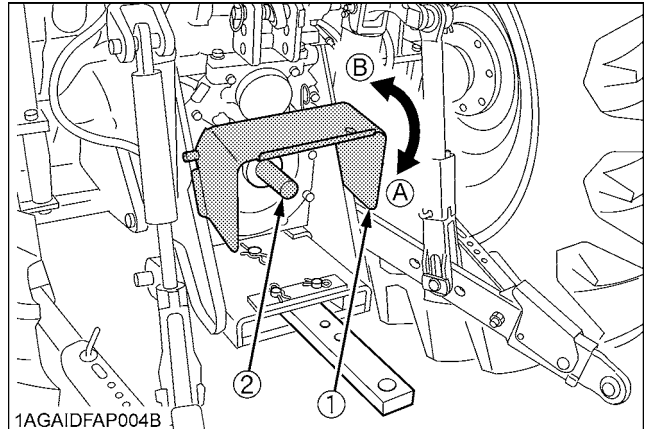

(1) PTO Shaft cover
(2) PTO Shaft cap

(A) "NORMAL POSITION"
(B) "RAISED POSITION"

3. Before installing or using PTO driven equipment, read the manufacturer's manual and review the safety labels attached to the equipment.
To prevent PTO driven equipment from improper or unsafe use, select the lower speed (540rpm) unless the higher one is specifically recommended as safe by the equipment manufacture.
4. When operating stationary PTO driven equipment, always apply the tractor parking brake and place chocks behind and in front of the rear wheels. Stay clear of all rotating parts. Never step over rotating parts.

5. USING 3-POINT HITCH

1. Use the 3-point hitch only with equipment designed for 3-point hitch usage.
2. When using a 3-point hitch mounted implement, be sure to install the proper counterbalance weight on the front of the tractor.
3. When transporting on the road, set the implement lowering speed knob in the "LOCK" position to hold the implement in the raised position.

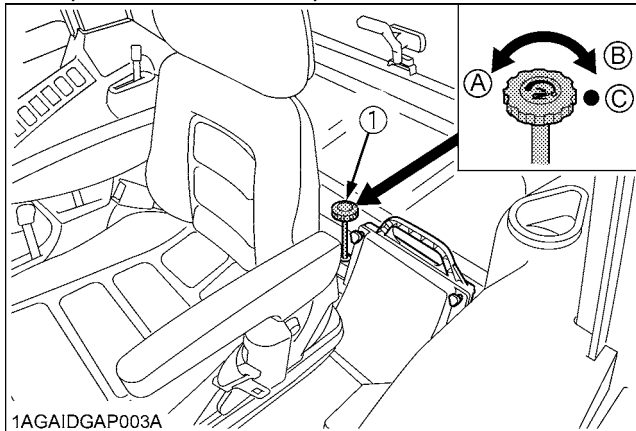

(1) 3-point hitch lowering speed knob

(A) "FAST"
(B) "SLOW"
(C) "LOCK"

6. SERVICING THE TRACTOR

Before servicing the tractor, park it on a firm, flat and level surface, set the parking brake, lower all implements to the ground, place the gear shift lever in neutral, stop the engine and remove the key.

1. Allow the tractor time to cool off before working on or near the engine, muffler, radiator, etc.
2. Do not remove radiator cap while coolant is hot. When cool, slowly rotate cap to the first stop and allow sufficient time for excess pressure to escape before removing the cap completely. If the tractor has a coolant recovery tank, add coolant or water to the tank, not the radiator. (See "Checking Coolant Level" in "DAILY CHECK" in "PERIODIC SERVICE" section.)
3. Always stop the engine before refueling. Avoid spills and overfilling.
4. Do not smoke when working around battery or when refueling. Keep all sparks and flames away from battery and fuel tank. The battery presents an explosive hazard, because it gives off hydrogen and oxygen especially when recharging.
5. Before "jump starting" a dead battery, read and follow all of the instructions. (See "JUMP STARTING" in "OPERATING THE ENGINE" section.)
6. Keep first aid kit and fire extinguisher handy at all times.

7. Disconnect the battery's ground cable before working on or near electric components.
8. To avoid the possibility of battery explosion, do not use or charge the refillable type battery if the fluid level is below the LOWER (lower limit level) mark. Check the fluid level regularly and add distilled water as required so that the fluid level is between the UPPER and LOWER levels.
9. To avoid sparks from an accidental short circuit, always disconnect the battery's ground cable (-) first and reconnect it last.

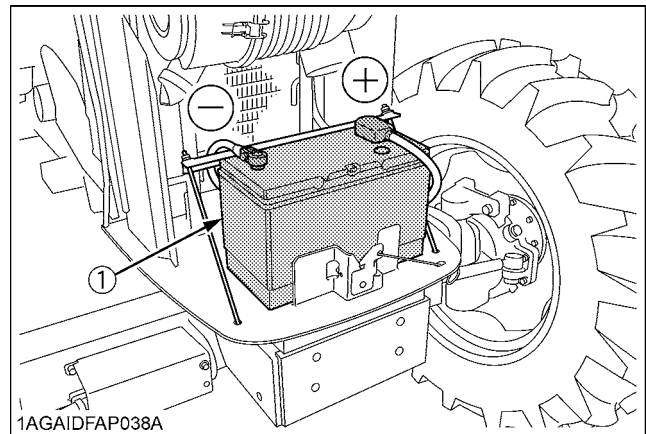

(1) Battery

10. Do not attempt to mount a tire on a rim. This should be done by a qualified person with the proper equipment.
11. Always maintain the correct tire pressure. Do not inflate tires above the recommended pressure shown in the operator's manual.

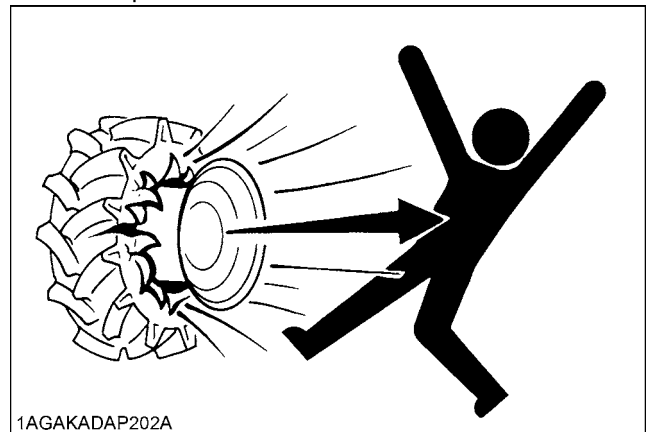

1AGAKADAP202A

12. Securely support the tractor when either changing wheels or adjusting the wheel tread width.
13. Make sure that wheel bolts have been tightened to the specified torque.
14. Disconnect the battery's ground cable and stop the engine to avoid the possibility of the machine runaway due to 4WD braking system during testing, service or repair with only rear wheels off the ground.

▲-6 SAFE OPERATION

15. Do not work under any hydraulically supported devices. They can settle, suddenly leak down, or be accidentally lowered. If it is necessary to work under tractor or any machine elements for servicing or adjustment, securely support them with stands or suitable blocking beforehand.
16. Escaping hydraulic fluid under pressure has sufficient force to penetrate skin, causing serious personal injury. Before disconnecting hydraulic lines, be sure to release all residual pressure. Before applying pressure to the hydraulic system, make sure that all connections are tight and that all lines, pipes, and hoses are free of damage.

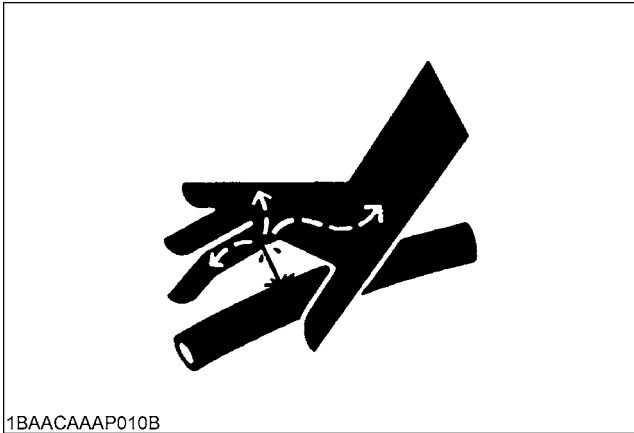

17. Fluid escaping from pinholes may be invisible. Do not use hands to search for suspected leaks; use a piece of cardboard or wood. Use of safety goggles or other eye protection is also highly recommended. If injured by escaping fluid, see a medical doctor at once. This fluid will produce gangrene or severe allergic reaction.

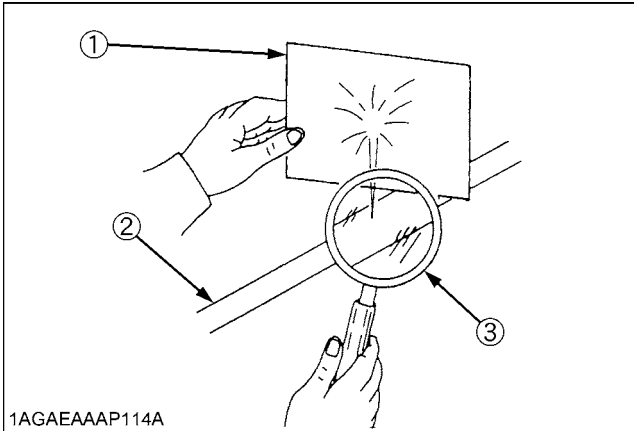

- (1) Cardboard
- (2) Hydraulic line
- (3) Magnifying glass

7. DANGER, WARNING AND CAUTION LABELS

(1) Part No. 6C090-4958-2
Do not get your hands close
to engine fan and fan belt.



(2) Part No. K3512-4719-1
Do not touch hot surface
like muffler, etc.



(3) Part No. 6C040-4741-2

No fire

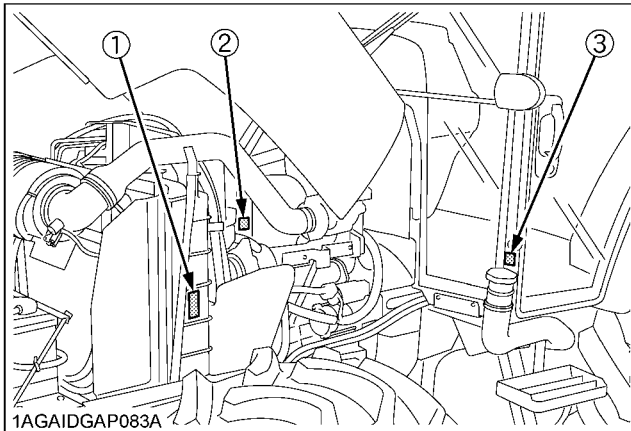

1AGAIDGAP080C

(1) Part No. 32310-4958-1

Do not touch hot surface like muffler, etc.

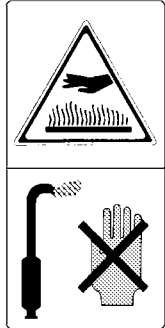

1AGAIAZAP071A

(2) Part No. 6C090-4958-2

Do not get your hands close to engine fan and fan belt.



1AGAIAZAP110A

(3) Part No. 3A851-7295-1

<p>▲ CAUTION REFRIGERANT UNDER HIGH PRESSURE</p> <p>Improper service methods may cause injury. Air conditioning system should be serviced by qualified personnel. See Repair Manual.</p> <p>Refrigerant HFC134a Max. 0.95kg (2.09lbs.) USE ONLY Min. 0.85kg (1.87lbs.)</p>	<p>Oil ND-OIL 8 SAE OR EQUIVALENT J-639</p>	<p>▲ ATTENTION REFRIGERANT SOUS HAUTE PRESSION</p> <p>Un entretien incorrect peut provoquer des blessures. Le système de climatisation doit être entretenu par une personne qualifiée. Voir le manuel de réparation.</p> <p>Refrigerant HFC134a Max. 0.95kg (2.09lbs.) UNIQUEMENT Min. 0.85kg (1.87lbs.)</p>	<p>Huile ND-OIL 8 SAE OU EQUIVALENTE J-639</p>	<p>J96</p>
<p>MFD. BY DENSO CORPORATION JAPAN. FABRIQUE PAR DENSO CORPORATION JAPON.</p>				

1AGAIDGAP074A

(4) Part No. 3Y205-9892-1

▲ DANGER/POISON

<p>SHIELD EYES. EXPLOSIVE GASES CAN CAUSE BLINDNESS OR INJURY.</p>	<p>NO SPARKS, FLAMES, SMOKING.</p>	<p>SULFURIC ACID CAN CAUSE BLINDNESS OR SEVERE BURNS.</p>
---	---	--

KEEP OUT OF REACH OF CHILDREN. DO NOT TIP. DO NOT OPEN BATTERY.

FLUSH EYES IMMEDIATELY WITH WATER. GET MEDICAL HELP FAST.

PROPOSITION 65 WARNING
BATTERY POSTS, TERMINALS, AND RELATED ACCESSORIES CONTAIN LEAD AND LEAD COMPOUNDS, CHEMICALS KNOWN TO THE STATE OF CALIFORNIA TO CAUSE CANCER AND REPRODUCTIVE HARM. WASH HANDS AFTER HANDLING.

105E41R 12V

AMP. HR (5HR)	80
AMP. HR (20HR)	100
RESERVE CAPACITY (MIN)	160
BCI CCA	900
EN CCA	800

S.O.C INDICATOR OK CHARGE REPLACE BATTERY BATTERY

Pb

DK 85330

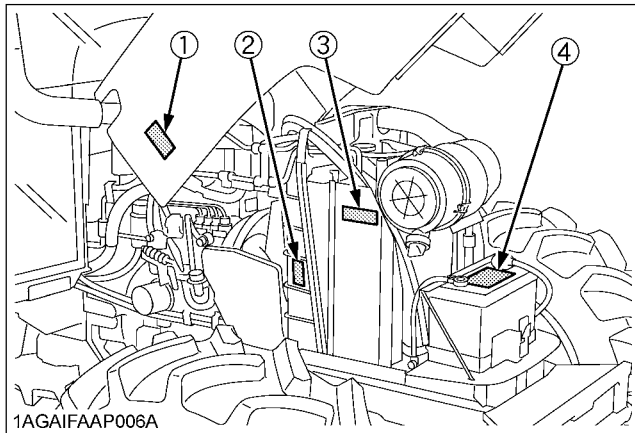

1AGAIFAAP006A

1AGAIDGAP081C

(1) Part No. 3F240-9857-1 [Hydraulic shuttle model]

⚠ WARNING
To avoid free wheeling when shifting the shuttle lever while on a slope : Stop completely by using the brake and by depressing the clutch pedal. Start off after selecting shuttle direction by releasing the clutch pedal.

1AGAIBDAP039A

(2) Part No. 3C581-9858-1

	⚠ DANGER
	TO AVOID POSSIBLE INJURY OR DEATH FROM A MACHINE RUNAWAY.
	<ol style="list-style-type: none"> 1. Do not start engine by shorting across starter terminals or bypassing the safety start switch. Machine may start in gear and move if normal starting circuitry is bypassed. 2. Start engine only from operator's seat with transmission and PTO OFF. Never start engine while standing on the ground.

1AGAIAZAP009A

(3) Part No. 6C150-4743-1 [Hydraulic shuttle model]

⚠ WARNING	BEFORE DISMOUNTING TRACTOR:
	<ol style="list-style-type: none"> 1. ALWAYS SET PARKING BRAKE. Leaving transmission in gear with the engine stopped will not prevent tractor from rolling. 2. PARK ON LEVEL GROUND WHENEVER POSSIBLE. If parking on a slope, position tractor across the slope. 3. LOWER ALL IMPLEMENTS TO THE GROUND. 4. STOP THE ENGINE.

1AGAIBDAP040A

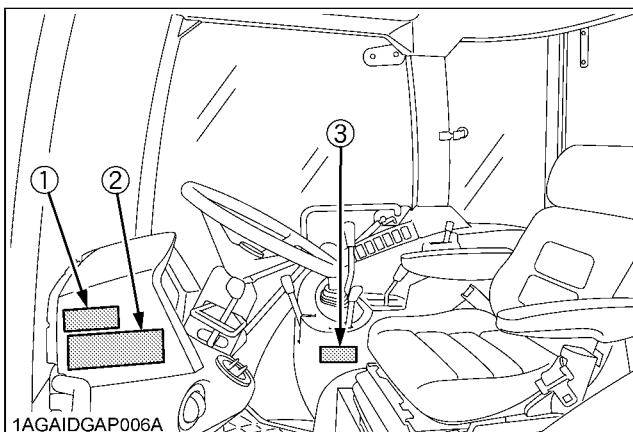

1AGAIDGAP006A

1AGAIDGAP072H

(1) Part No. 3F240-9836-2

▲ CAUTION

TO AVOID PERSONAL INJURY:

1. Read and understand the operator's manual before operation.
2. Before starting the engine, make sure that everyone is at a safe distance from tractor and the PTO is off.
3. Do not allow passengers on the tractor at any time.
4. Before allowing other people to use the tractor, have them read the operator's manual.
5. Check the tightness of nuts and bolts regularly.
6. Keep all shields in place and stay away from all moving parts.
7. Lock the two brake pedals together before driving on the road.
8. Slow down for turns, or rough roads, or when applying individual brakes.
9. On public roads use SMV emblem and hazard lights, if required by local traffic and safety regulations.
10. Pull only from the drawbar.
11. Before dismounting, lower the implement to the ground, set the parking brake, stop the engine and remove the key.
12. Securely support tractor and implements before working underneath.

1AGAICHAP113A

(2) Part No. TA040-4902-1

▲ WARNING

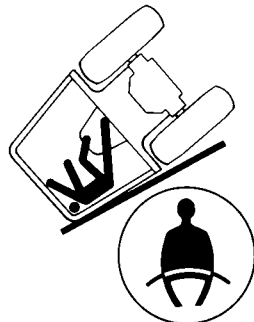

TO AVOID INJURY OR DEATH FROM ROLL-OVER:

Always use seat belt when driving.

1AGAMAOP078A

(3) Part No. 6C300-4744-1

▲ WARNING

Operation of this equipment may create sparks that can start fires around dry vegetation. A spark arrester may be required. The operator should contact local fire agencies for laws or regulations relating to fire prevention requirements.

1AGAIHFAP069A

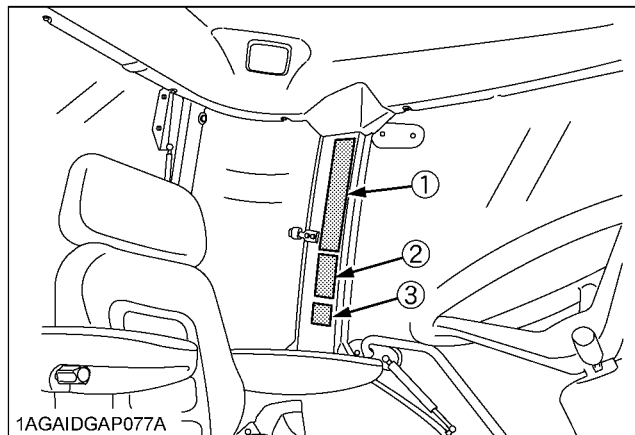

1AGAIDGAP077A

1AGAIDGAP071B

(1) Part No. 3P305-9856-1



1AGAICVAP046E

(2) Part No. TA040-4935-1



1AGAIAZAP056A

(3) Part No. TA040-4959-3

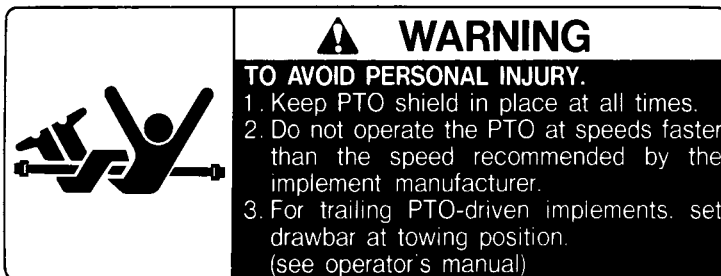

1AGAIAZAP116A

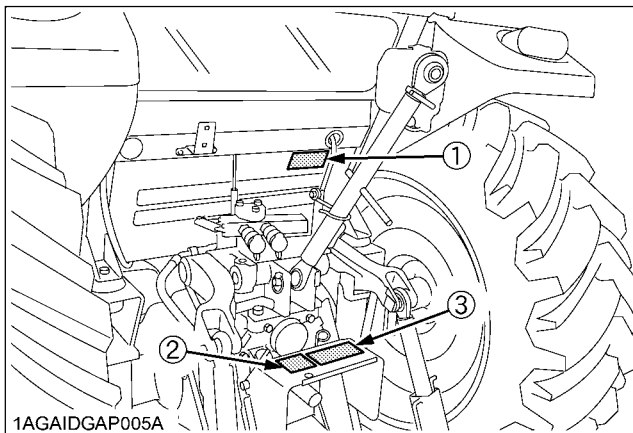

1AGAIDGAP005A

1AGAIDGAP073A

8. CARE OF DANGER, WARNING AND CAUTION LABELS

1. Keep danger, warning and caution labels clean and free from obstructing material.
2. Clean danger, warning and caution labels with soap and water, dry with a soft cloth.
3. Replace damaged or missing danger, warning and caution labels with new labels from your local KUBOTA Dealer.
4. If a component with danger, warning and caution label(s) affixed is replaced with new part, make sure new label(s) is (are) attached in the same location(s) as the replaced component.
5. Mount new danger, warning and caution labels by applying on a clean dry surface and pressing any bubbles to outside edge.

SERVICING OF TRACTOR

Your dealer is interested in your new tractor and has the desire to help you get the most value from it. After reading this manual thoroughly, you will find that you can do some of the regular maintenance yourself.

However, when in need of parts or major service, be sure to see your KUBOTA Dealer.

For service, contact the KUBOTA Dealership from which you purchased your tractor or your local KUBOTA Dealer. When in need of parts, be prepared to give your dealer the tractor, CAB and engine serial numbers.

Locate the serial numbers now and record them in the space provided.

	Type	Serial No.
Tractor		
CAB		
Engine		
Date of Purchase		
Name of Dealer		
(To be filled in by purchaser)		

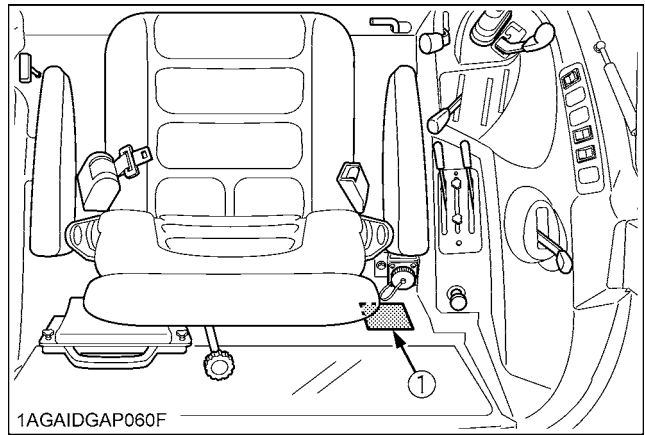

(1) CAB identification plate (CAB Serial No.)

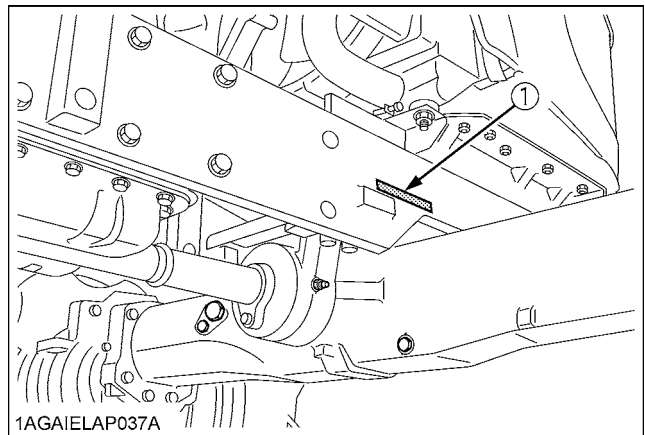

(1) Tractor serial number

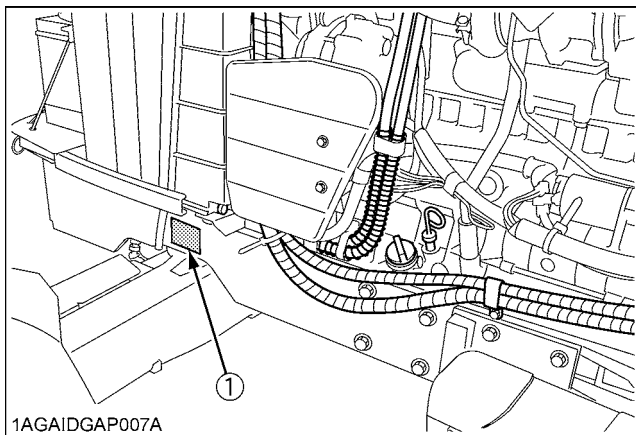

(1) Tractor identification plate

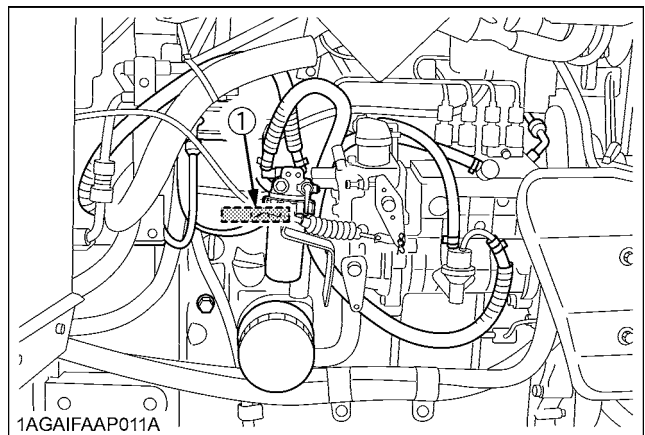

(1) Engine serial number

SPECIFICATIONS

SPECIFICATION TABLE

Model			M8540		M9540		
			2WD	4WD	2WD	4WD	
Engine	Model		V3800-DI-TE3				
	Type		Direct Injection, liquid cooled 4 cylinder diesel				
	Number of cylinders		4				
	Total displacement	cm ³ (cu.in.)	3769 (230)				
	Bore and stroke	mm (in.)	100 x 120 (3.9 x 4.7)				
	Rated revolution	rpm	2600				
	Low idling revolution	rpm	800 to 850				
	Net power *1	kW (HP)	63.7 (85.5)		70.8 (95)		
	PTO power *1 (factory observed)	kW (HP)	56.6 (76)		62.7 (84)		
	Maximum torque	N-m (ft-lbs) / rpm	286 (211) / 1500 to 1700		316 (233.1) / 1500 to 1700		
	Battery capacity		12V, RC: 160 min, CCA 900A				
	Fuel tank capacity	L (U.S.gals.)	110 (29.1)				
	Engine oil capacity	L (U.S.qts.)	10.7 (11.3)				
Coolant capacity	L (U.S.qts.)	9.0 (9.5)					
Dimensions	Overall length		mm (in.)	3885 (153)	3760 (148)	3885 (153)	3760 (148)
	Overall width (minimum tread)		mm (in.)	1990 (78)		2010 (79)	
	Overall height		mm (in.)	2545 (100)		2570 (101)	
	Wheel base		mm (in.)	2250 (88.6)			
	Tread	Front	mm (in.)	1440 to 2040 (56.7 to 80.3)	1520, 1620 (59.8, 63.8)	1440 to 2040 (56.7 to 80.3)	1520, 1620 (59.8, 63.8)
		Rear	mm (in.)	1520 to 1920 (59.8 to 75.6)			
Minimum ground clearance		mm (in.)	425 (16.7) (Drawbar bracket)		450 (17.7) (Drawbar bracket)		
Weight		kg (lbs.)	2540 (5600)	2740 (6040)	2580 (5690)	2800 (6175)	
Traveling system	Standard tire size	Front tires	7.5-18	11.2-24	7.5-18	12.4-24	
		Rear tires *2	18.4-28	18.4-28	18.4-30	18.4-30	
	Clutch		Dry single plate / Multiple wet disks				
	Steering		Hydraulic Power Steering				
	Braking system		Hydraulic wet disks				
Differential		Bevel gears with diff. lock (Rear)					

Model			M8540		M9540		
			2WD	4WD	2WD	4WD	
Hydraulic unit	Hydraulic control system			Position, draft (top link sensing) & mix control			
	Pump capacity		L (U.S.gals.) / min	64.3 (17.0)			
	Three point hitch			Category 2			
	Max. lifting force	At lifting points *3	kg (lbs.)	2500 (5510), 3900 (8600) with Hydraulic High Capacity Lift Cylinders (F24 / R24, F12 / R12 model: standard) (F8 / R8 model: option)			
		24 in. behind lifting point	kg (lbs.)	2100 (4630), 3300 (7275) with Hydraulic High Capacity Lift Cylinders (F24 / R24, F12 / R12 model: standard) (F8 / R8 model: option)			
	Remote hydraulic control			1 standard (2nd, 3rd & flow control valve optional)			
	System pressure		MPa (kgf/cm ²)	19.6 (200)			
	Traction system			Swinging drawbar, adjustable in direction			
PTO	Live PTO (Independent)	Direction of turning		Clockwise, viewed from tractor rear			
		PTO/ Engine speed	rpm	6 spline: 540 / 2205			



The company reserves the right to change the specifications without notice.

- NOTE:** *1 Manufacturer's estimate
 *2 Cast iron disks available for wheels.
 *3 At lower link end with links horizontal.

TRAVELING SPEEDS

◆ Without Dual Speed model

(At rated engine rpm)

Model			M8540 / M9540			
			F8 / R8 model		F12 / R12 model	
Tire size (Rear)			18.4-30			
Shuttle shift lever	Range gear shift lever	Main gear shift lever	km/h	mph	km/h	mph
Forward 	CREEP (option)	1	0.42	0.26	0.42	0.26
		2	0.63	0.39	0.54	0.34
		3	0.91	0.56	0.71	0.44
		4	1.3	0.81	0.91	0.56
		5	---	---	1.12	0.70
		6	---	---	1.35	0.84
	L	1	2.6	1.6	2.6	1.6
		2	4.0	2.5	3.4	2.1
		3	5.7	3.6	4.5	2.8
		4	8.2	5.1	5.7	3.6
		5	---	---	7.1	4.4
		6	---	---	8.5	5.3
	H	1	10.4	6.5	10.4	6.5
		2	15.7	9.7	13.4	8.4
		3	22.6	14.1	17.7	11.0
		4	32.4	20.1	22.6	14.1
		5	---	---	28.0	17.5
		6	---	---	33.7	21.1
Reverse 	CREEP (option)	1	0.42	0.26	0.42	0.26
		2	0.62	0.39	0.53	0.33
		3	0.90	0.56	0.70	0.44
		4	1.3	0.80	0.90	0.56
		5	---	---	1.11	0.70
		6	---	---	1.34	0.84
	L	1	2.6	1.6	2.6	1.6
		2	3.9	2.5	3.4	2.1
		3	5.7	3.5	4.4	2.8
		4	8.2	5.1	5.7	3.5
		5	---	---	7.0	4.4
		6	---	---	8.5	5.3
	H	1	10.4	6.4	10.4	6.4
		2	15.6	9.7	13.3	8.3
		3	22.5	14.0	17.5	10.9
		4	32.2	20.0	22.5	14.0
		5	---	---	27.8	17.4
		6	---	---	33.4	20.9

The company reserves the right to change the specifications without notice

◆ With Dual Speed model

(At rated engine rpm)

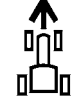
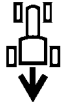
Model			M9540			
Tire size (Rear)			F24 / R24 model			
Tire size (Rear)			18.4-30			
Shuttle shift lever	Range gear shift lever	Main gear shift lever	Dual speed: H		Dual speed: L	
			km/h	mph	km/h	mph
Forward 	CREEP (option)	1	0.44	0.28	0.37	0.23
		2	0.57	0.35	0.48	0.30
		3	0.75	0.47	0.63	0.39
		4	0.96	0.60	0.80	0.50
		5	1.19	0.74	1.00	0.62
		6	1.43	0.89	1.20	0.75
	L	1	2.8	1.7	2.4	1.5
		2	3.6	2.2	3.0	1.9
		3	4.7	3.0	4.0	2.5
		4	6.1	3.8	5.1	3.2
		5	7.5	4.7	6.3	3.9
		6	9.0	5.6	7.6	4.7
	H	1	11.0	6.9	9.3	5.8
		2	14.1	8.8	11.9	7.4
		3	18.6	11.6	15.7	9.8
		4	23.9	14.9	20.1	12.5
		5	29.6	18.5	24.9	15.6
		6	35.6	22.2	29.9	18.7
Reverse 	CREEP (option)	1	0.45	0.28	0.38	0.23
		2	0.57	0.36	0.48	0.30
		3	0.76	0.47	0.64	0.40
		4	0.97	0.61	0.81	0.51
		5	1.20	0.75	1.01	0.63
		6	1.44	0.90	1.21	0.76
	L	1	2.8	1.8	2.4	1.5
		2	3.6	2.3	3.1	1.9
		3	4.8	3.0	4.0	2.5
		4	6.1	3.8	5.2	3.2
		5	7.6	4.7	6.4	4.0
		6	9.1	5.7	7.7	4.8
	H	1	11.2	7.0	9.4	5.9
		2	14.3	9.0	12.0	7.5
		3	18.9	11.8	15.9	9.9
		4	24.2	15.1	20.3	12.7
		5	30.0	18.7	25.2	15.7
		6	36.0	22.5	30.3	18.9

The company reserves the right to change the specifications without notice

IMPLEMENT LIMITATIONS

The KUBOTA Tractor has been thoroughly tested for proper performance with implements sold or approved by KUBOTA. Use with implements which are not sold or approved by KUBOTA and which exceed the maximum specifications listed below, or which are otherwise unfit for use with the KUBOTA Tractor may result in malfunctions or failures of the tractor, damage to other property and injury to the operator or others. [Any malfunctions or failures of the tractor resulting from use with improper implements are not covered by the warranty.]

	Tread (max. width)			Lower link end max. lifting capacity: W 0
	Front		Rear	
	2WD	4WD		
M8540 M9540	2040 mm (80.3 in.)	1620 mm (63.8 in.)	1920 mm (75.6 in.)	Hydraulic high capacity lift cylinder equipped: 3900 kg (8600 lbs.) non-equipped: 2500 kg (5510 lbs.)

	Implement weight: W 1	Max. drawbar Load: W 2	Trailer loading weight: W 3	
			2WD	4WD
M8540 M9540	As in the following list (Shown on the next page)	1500 kg (3300 lbs.)	6000 kg (13200 lbs.)	7000 kg (15400 lbs.)

Lower link end max, hydraulic lifting capacity.....W 0
 Implement weight.....The implement's weight which can be put on the lower link: W 1
 Max. drawbar load.....W 2
 Trailer loading weight.....The max. loading weight for trailer (without trailer's weight): W 3

The diagrams show a tractor with a front wheel and a rear wheel. The first diagram shows the rear wheel lifting a weight W0. The second diagram shows a weight W1 being supported by the lower link of the rear wheel. The third diagram shows a trailer being pulled by the rear wheel, with W2 representing the drawbar load and W3 representing the trailer's loading weight.

1AGAIAZAP121B

- NOTE :**
- Implement size may vary depending on soil operating conditions.

No.	Implement		Remarks		M8540		M9540		
					2WD	4WD	2WD	4WD	
1	Slurry Tank		Max. Tank Capacity	L (gals.)	4000 (1060)				
			Max. Load Capacity	kg (lbs.)	5000 (11000)				
2	Trailer		Max. Load Capacity	kg (lbs.)	5000 (11000)	6000 (13200)	5000 (11000)	6000 (13200)	
			Max. Drawbar Load	kg (lbs.)	1500 (3300)				
3	Mower	Rotary-Cutter	Max. Cutting Width	mm (in.)	2300 (90)				
			Max. Weight	kg (lbs.)	600 (1320)				
		Flail Mower (Heavy)	Max. Cutting Width	mm (in.)	3660 (144)				
			Max. Weight	kg (lbs.)	1000 (2200)				
Sickle Bar	Max. Cutting Width	mm (in.)	2743 (108)						
4	Sprayer		Max. Tank-Capacity	Mid	L (gals.)	800 (200)		1000 (260)	
				Rear 3P	L (gals.)	800 (200)		1000 (260)	
				Drawbar	L (gals.)	4000 (1030)	4500 (1200)		5000 (1320)
5	Rotary Tiller		Max. Tilling Width	mm (in.)	2400 (96)				
			Max. Weight	kg (lbs.)	1000 (2200)				
6	Bottom Plow		Max. Size		16 in. x 3 18 in. x 2	16 in. x 4 18 in. x 3 24 in. x 1	16 in. x 4 18 in. x 3	14 in. x 5 16 in. x 4 20 in. x 3 24 in. x 1	
			Max. Weight	kg (lbs.)	3P Type	650 (1400)	750 (1650)	900 (2000)	
7	Disk harrow	3P Type	Max. Size		20 in. x 24	24 in. x 24	24 in. x 24	24 in. x 28	
			Max. Harrowing Width	mm (in.)	2450 (96)	2850 (112)		3300 (130)	
			Max. Weight	kg (lbs.)	650 (1400)	750 (1650)	900 (2000)		
		Drawbar Type	Max. Harrowing Width	mm (in.)	3050 (120)	3660 (144)		4300 (168)	
8	Disc Plow		Max. Size		26 in. x 3 28 in. x 3	26 in. x 4 28 in. x 4	26 in. x 4 28 in. x 4		
			Max. Weight	kg (lbs.)	650 (1400)	750 (1650)	900 (2000)		
9	Sub Soiler		Numbers of Cultivating Tines		2				
			Cultivating Depth	mm (in.)	450 (18)	500 (20)		550 (22)	
10	Cultivator		Max. Width	mm (in.)	4270 (168)	4880 (192)		5490 (216)	
			Number of Rows		6				
			Max. Weight	kg (lbs.)	650 (1400)	750 (1650)	900 (2000)		
11	Front Blade *1, *2		Max. Cutting Width	mm (in.)	2130 (84)	2430 (96)		2600 (102)	
			Max. Oil Pressure	MPa (psi.)	19.6 (2842)				
12	Rear Blade		Max. Cutting Width	mm (in.)	2130 (84)	2430 (96)		2600 (102)	
			Max. Oil Pressure	MPa (psi.)	19.6 (2842)				
13	Front Loader *1, *2		Max. Lifting Capacity	kg (lbs.)	1350 (2976)				
			Max. Oil Pressure (Extra Hydro Kit)	MPa (psi.)	20.5 (2973)				
14	Box Blade		Max. Cutting Width	mm (in.)	2130 (84)	2430 (96)	2130 (84)	2430 (96)	
			Max. Weight	kg (lbs.)	650 (1400)	750 (1650)	800 (1760)		
15	Back Hoe *2		Max. Digging Depth	mm (in.)	3050 (120)				
			Max. Weight	kg (lbs.)	1200 (2650)				
16	Snow Blade		Max. Width	mm (in.)	2130 (84)	2430 (96)		2600 (102)	
			Max. Weight	kg (lbs.)	650 (1400)	750 (1650)	800 (1760)		

NOTE :

● Implement size may vary depending on soil operating conditions.

*1 Must remove front weight with this implement.

*2 Need subframe

INSTRUMENT PANEL AND CONTROLS

■ Instrument Panel, Switches and Hand Controls

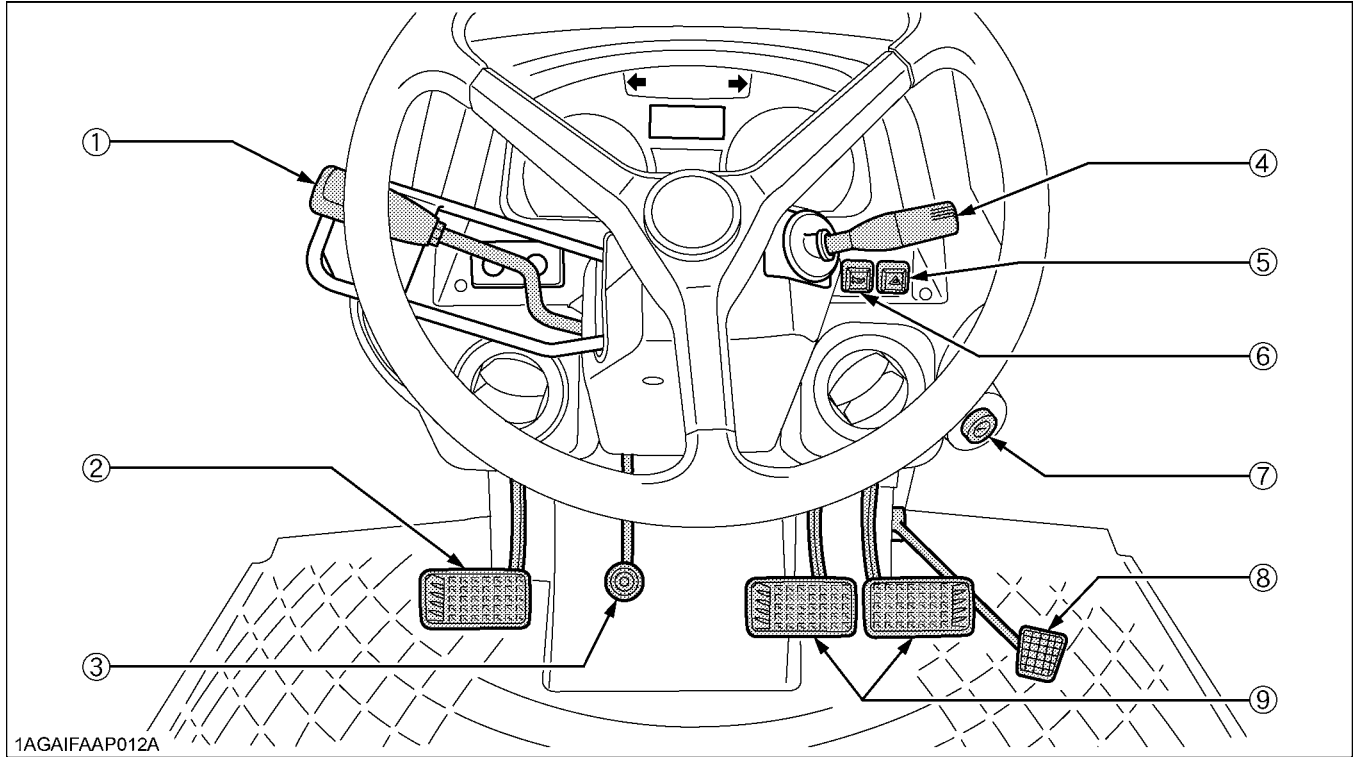

1AGAIFAAP012A

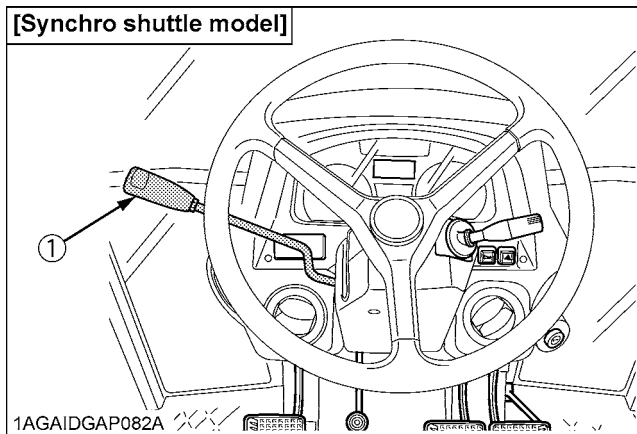

1AGAI DGAP082A

ILLUSTRATED CONTENTS

(1) Hydraulic-shuttle shift lever [Hydraulic shuttle model].....	25
(1) Synchro-shuttle shift lever [Synchro shuttle model].....	26
(2) Clutch pedal.....	24
(3) Tilt pedal.....	21
(4) Turn signal / Head light switch.....	21, 21
(5) Hazard light switch.....	21
(6) Horn button.....	22
(7) Key switch.....	-
(8) Foot throttle.....	31
(9) Brake pedal.....	22

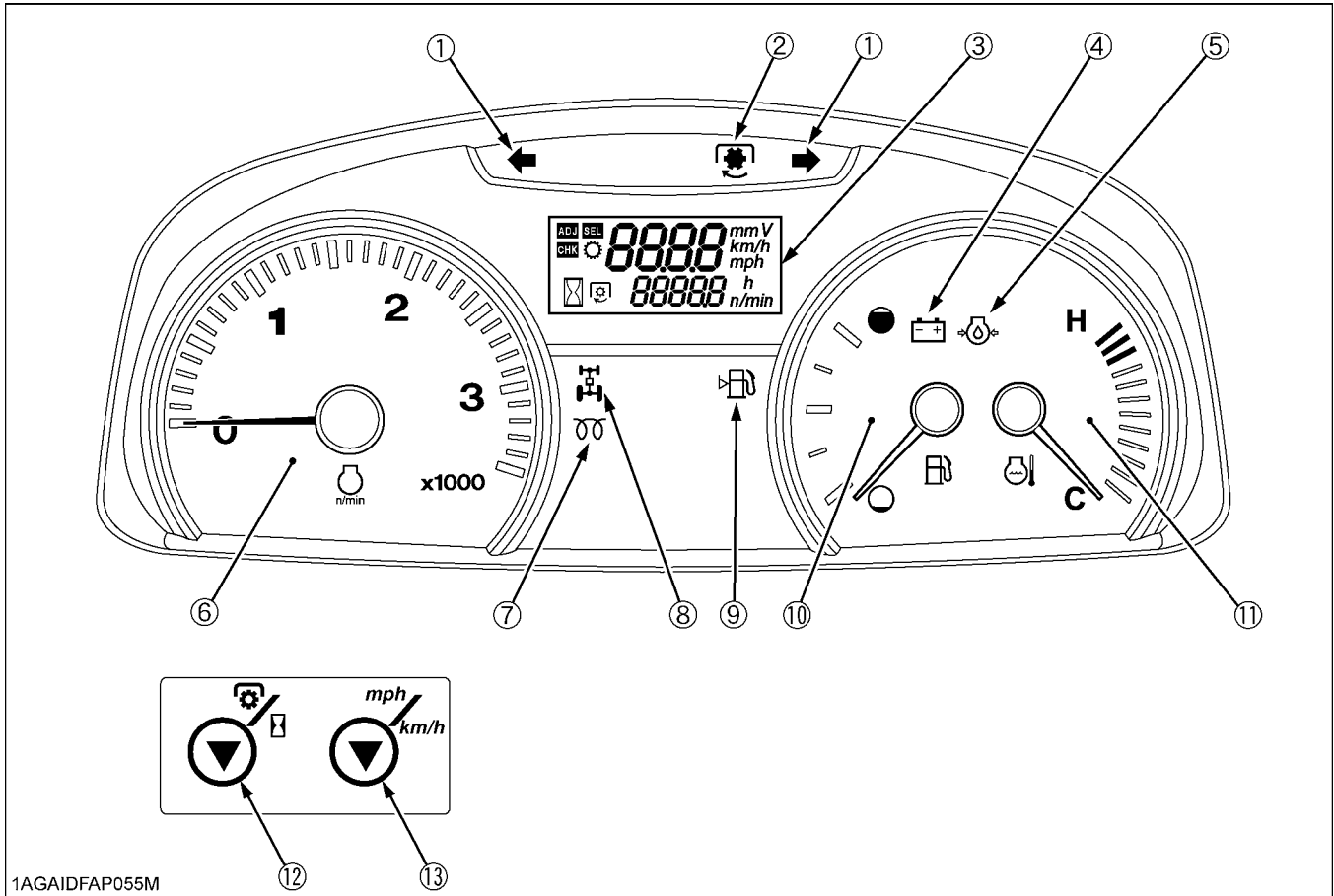

ILLUSTRATED CONTENTS

(1) Hazard / Turn signal indicator	21
(2) PTO clutch indicator	41
(3) Liquid crystal display.....	34
(4) Electrical charge indicator	32
(5) Engine oil pressure indicator	32
(6) Tachometer	33
(7) Heater indicator	17

ILLUSTRATED CONTENTS

(8) 4WD indicator	29
(9) Fuel level indicator.....	32
(10) Fuel gauge.....	32
(11) Coolant temperature gauge	33
(12) PTO / Hour meter select switch	34
(13) Travel speed select switch.....	34

■ **Foot and Hand Controls**

◆ **Without Dual Speed model**

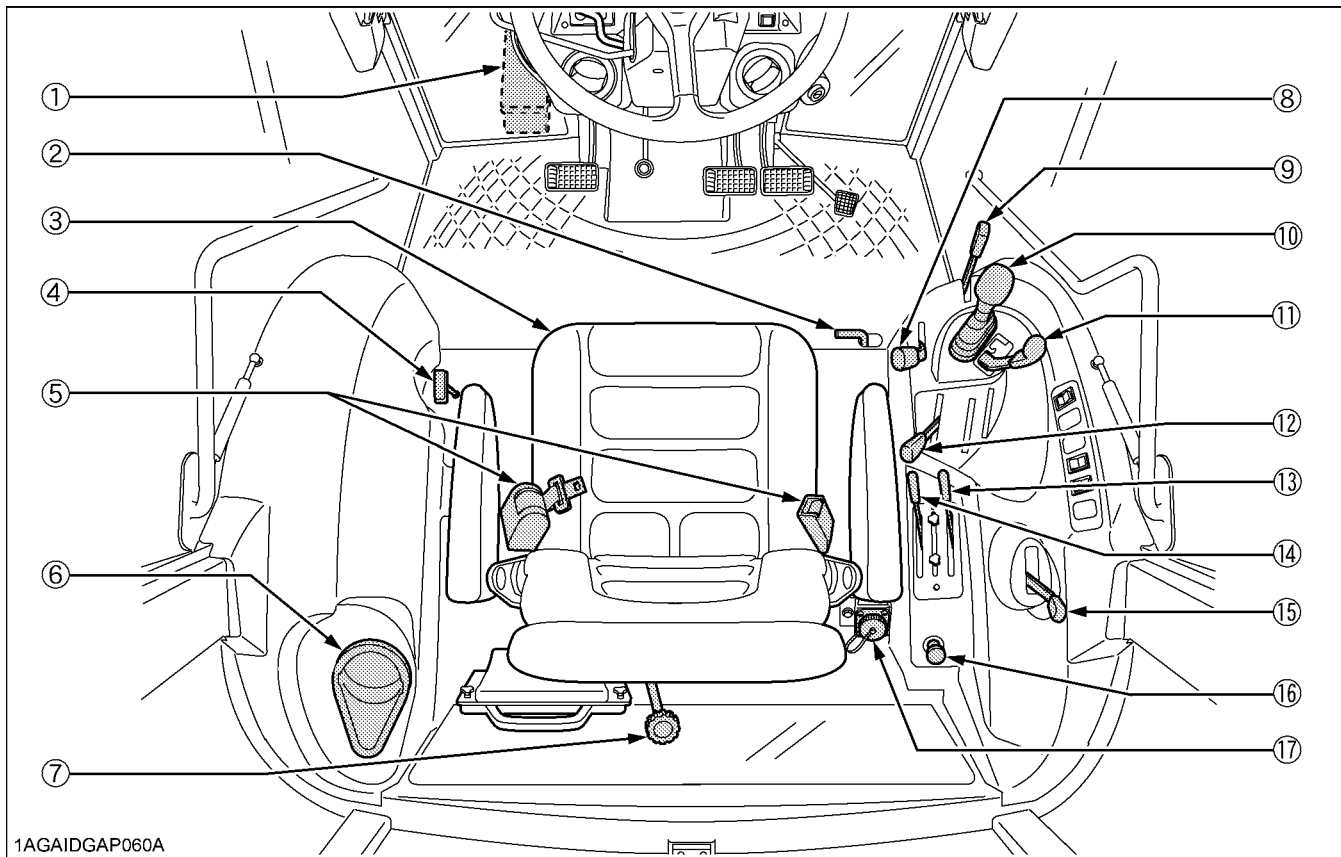

1AGAIDGAP060A

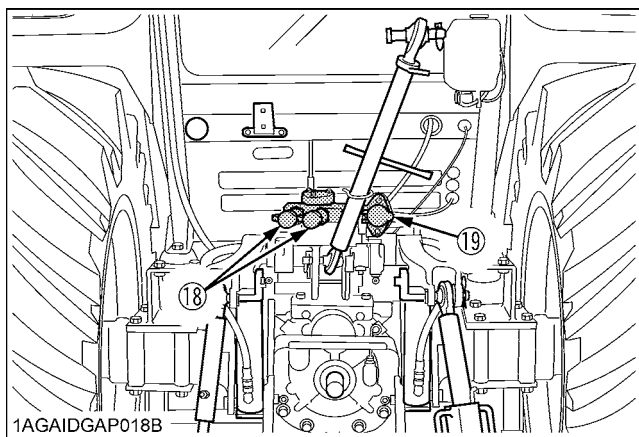

1AGAIDGAP018B

ILLUSTRATED CONTENTS

(1) Tool box.....	-
(2) Differential lock pedal.....	39
(3) Operator's seat.....	19
(4) Front wheel drive lever.....	29
(5) Seat belt.....	20
(6) Cup holder.....	-
(7) 3-Point hitch lowering speed knob.....	51
(8) Hand throttle lever.....	31
(9) Range gear shift lever.....	25, 26
(10) Main gear shift lever.....	25, 26
(11) Parking brake lever.....	13, 31
(12) Remote control valve lever.....	52
(13) Position control lever.....	50
(14) Draft control lever.....	50
(15) PTO clutch control lever.....	41
(16) Cigarette lighter.....	69
(17) Electrical outlet.....	69
(18) Remote control valve coupler.....	52
(19) Trailer electrical outlet.....	40

◆ With Dual Speed model

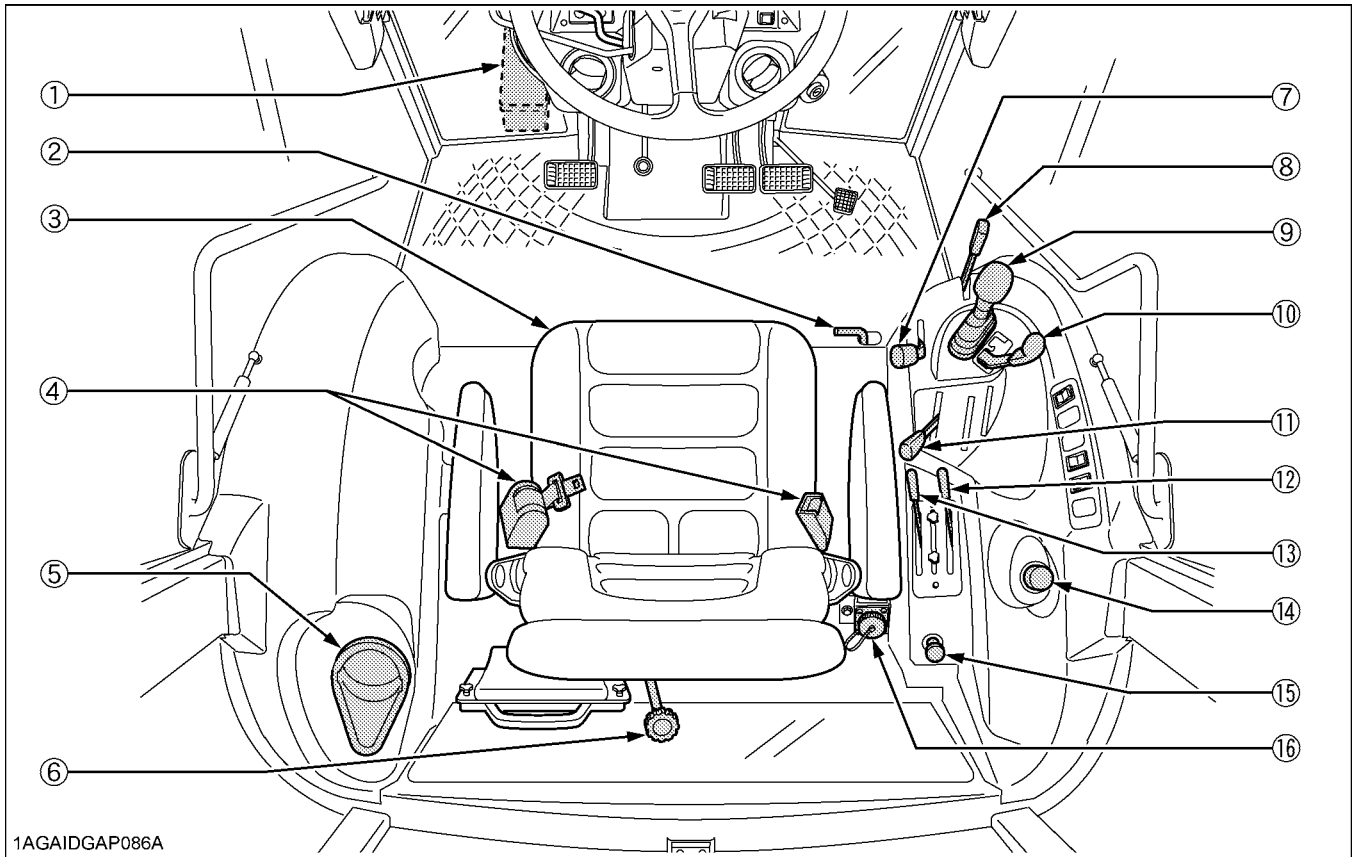

1AGAIDGAP086A

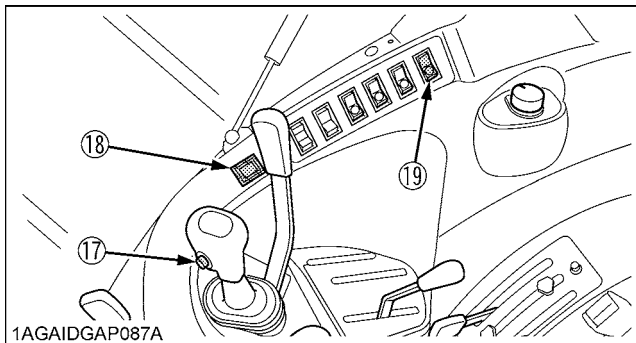

1AGAIDGAP087A

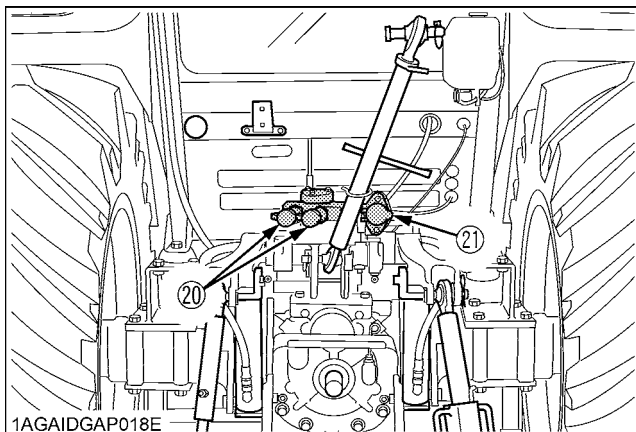

1AGAIDGAP018E

ILLUSTRATED CONTENTS

(1) Tool box.....	-
(2) Differential lock pedal.....	39
(3) Operator's seat.....	19
(4) Seat belt.....	20
(5) Cup holder.....	-
(6) 3-Point hitch lowering speed knob.....	51
(7) Hand throttle lever.....	31
(8) Range gear shift lever.....	25, 26
(9) Main gear shift lever.....	25, 26
(10) Parking brake lever.....	13, 31
(11) Remote control valve lever.....	52
(12) Position control lever.....	50
(13) Draft control lever.....	50
(14) PTO clutch control switch.....	41
(15) Cigarette lighter.....	69
(16) Electrical outlet.....	69
(17) Dual speed shift switch.....	28
(18) Dual speed shift indicator.....	28
(19) Front wheel drive switch (4WD).....	30
(20) Remote control valve coupler.....	52
(21) Trailer electrical outlet.....	40

PRE-OPERATION CHECK

DAILY CHECK

To prevent trouble from occurring, it is important to know the condition of the tractor well. Check it before starting.



CAUTION

To avoid personal injury:

- **Be sure to check and service the tractor on a level surface with the engine shut off and the parking brake "ON" and implement lowered to the ground.**

Check item

- Walk around inspection
- Check engine oil level
- Check transmission oil level
- Check coolant level
- Clean air conditioner condenser screen
- Check washer liquid level
- Check water separator
- Clean grill and radiator screen
- Clean oil cooler
- Check air cleaner evacuator valve
(When used in a dusty place)
- Check brake pedal [Hydraulic shuttle model]
- Check brake and clutch pedal [Synchro shuttle model]
- Check air cleaner dust indicator
(When used in a dusty place)
- Check indicators, gauges and meter
- Check lights
- Check seat belt and ROPS
- Refuel
(See "DAILY CHECK" in "PERIODIC SERVICE" section.)
- Care of danger, warning and caution labels
(See "DANGER, WARNING AND CAUTION LABELS" in "SAFE OPERATION" section.)

OPERATING THE ENGINE



CAUTION

To avoid personal injury:

- Read "Safe Operation" in the front of this manual.
- Read the danger, warning and caution labels located on the tractor.
- To avoid the danger of exhaust fume poisoning, do not operate the engine in a closed building without proper ventilation.
- Never start engine while standing on ground. Start engine only from operator's seat.
- Make it a rule to set all shift levers to the "NEUTRAL" positions and to place PTO lever in "OFF" position before starting the engine.

IMPORTANT :

- Do not use starting fluid or ether.
- To protect the battery and the starter, make sure that the starter is not continuously turned for more than 10 seconds.

STARTING THE ENGINE

1. Make sure the parking brake is set.

1. To set the parking brake;
 - (1) Depress the brake pedals.
 - (2) Place the main gear shift lever in neutral position.
 - (3) Push the parking brake lever to parking position.
2. To release the parking brake, depress the brake pedals and shift the lever to transport position.

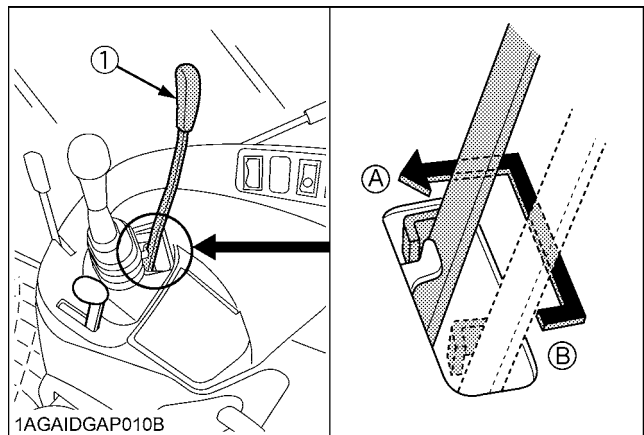

(1) Parking brake lever

(A) "PARKING POSITION"

(B) "TRANSPORT POSITION"

IMPORTANT :

- Bring the tractor to a complete stop before applying the parking brake lever.
- The parking brake lever can be turned ON and OFF only when the main gear shift lever is at the neutral position.

NOTE :

- In moving the parking brake lever, you may feel it heavy some time or light other time. This is not a trouble, however.

2. Make sure the fuel cock is in the "OPEN" position.

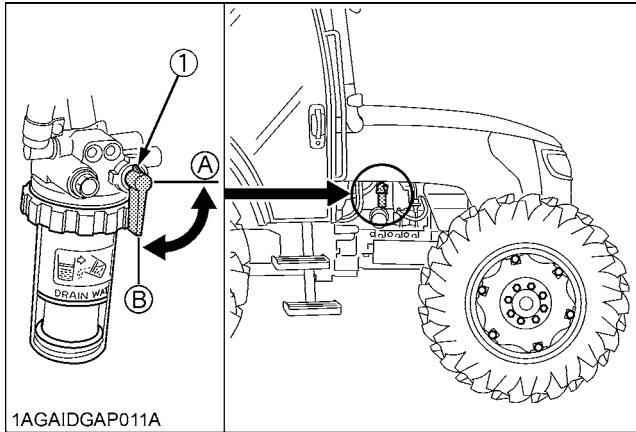

1AGAIDGAP011A

(1) Fuel cock

(A) "CLOSE"
(B) "OPEN"

3. Place the shift levers in "NEUTRAL" position.

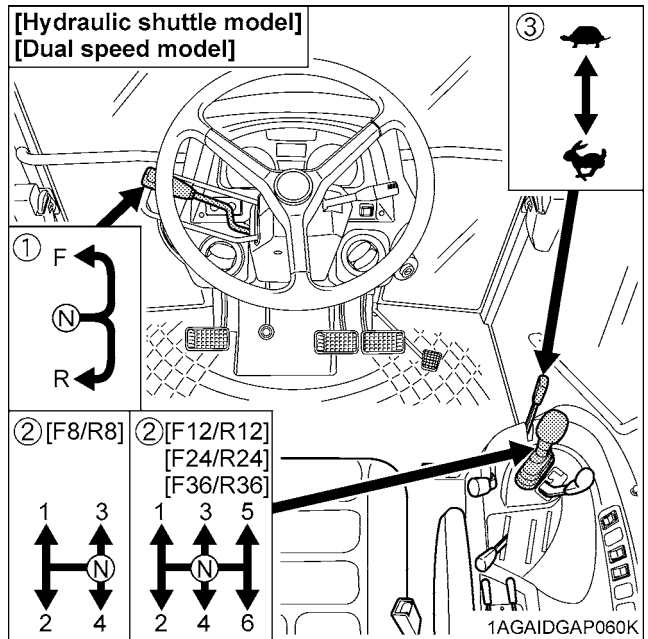

1AGAIDGAP060K

(1) Hydraulic-shuttle shift lever (N) "NEUTRAL POSITION"
(2) Main gear shift lever ⬇️ "LOW"
(3) Range gear shift lever ⬆️ "HIGH"

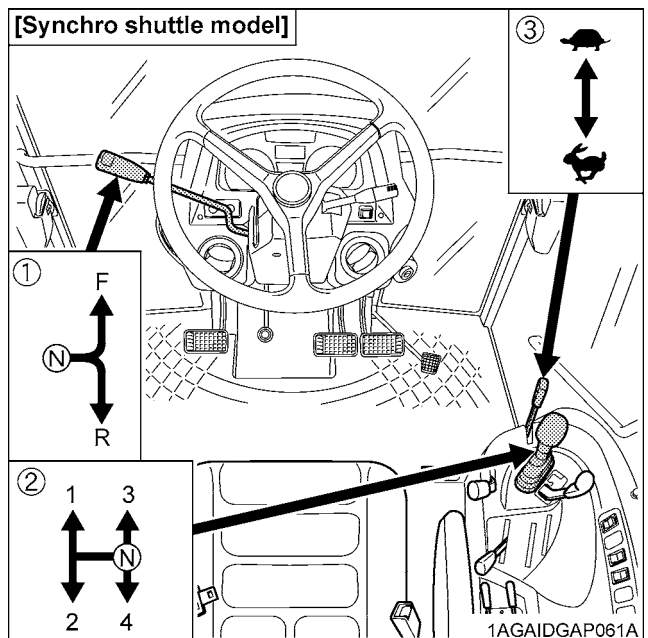

1AGAIDGAP061A

(1) Synchro shuttle shift lever (N) "NEUTRAL POSITION"
(2) Main gear shift lever ⬇️ "LOW"
(3) Range gear shift lever ⬆️ "HIGH"

4. Place the PTO clutch control lever in "OFF" position and hydraulic control levers in "LOWEST" position.

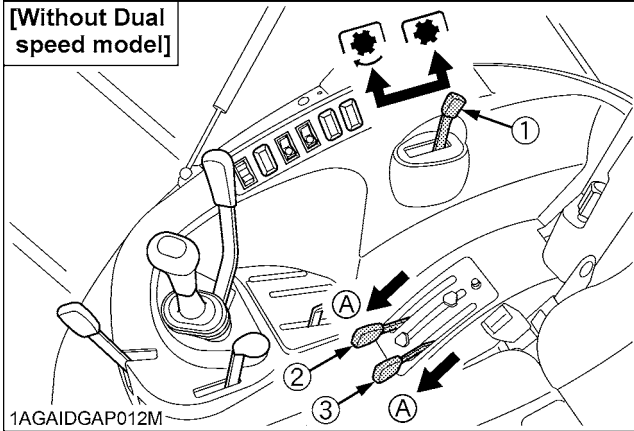

- (1) PTO clutch control lever ☒ "ON" ☒ "OFF"
- (2) Position control lever (A) "DOWN"
- (3) Draft control lever

4. Place the PTO clutch control switch in "OFF" position and hydraulic control levers in "LOWEST" position.

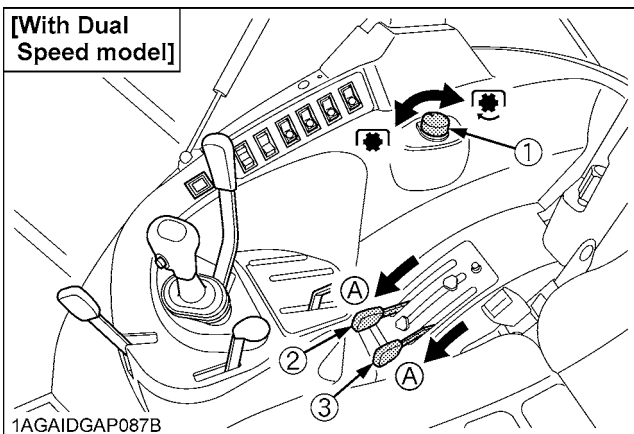

- (1) PTO clutch control switch ☒ "ON" ☒ "OFF"
- (2) Position control lever (A) "DOWN"
- (3) Draft control lever

5. Set the throttle lever to about 1/2 way.

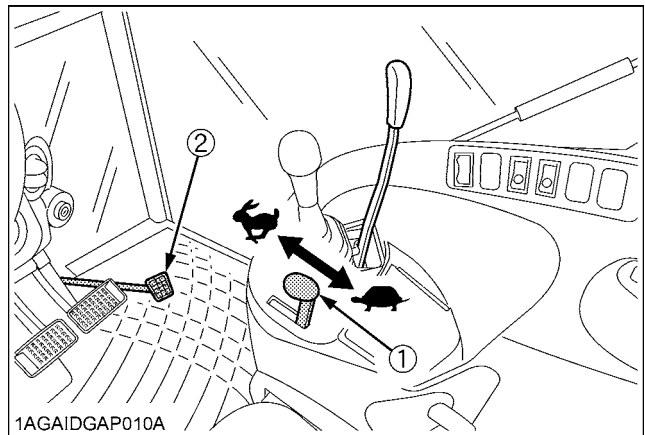

- (1) Hand throttle lever ⬆ "INCREASE"
- (2) Foot throttle ⬇ "DECREASE"

6. Insert the key into the key switch and turn it "ON".

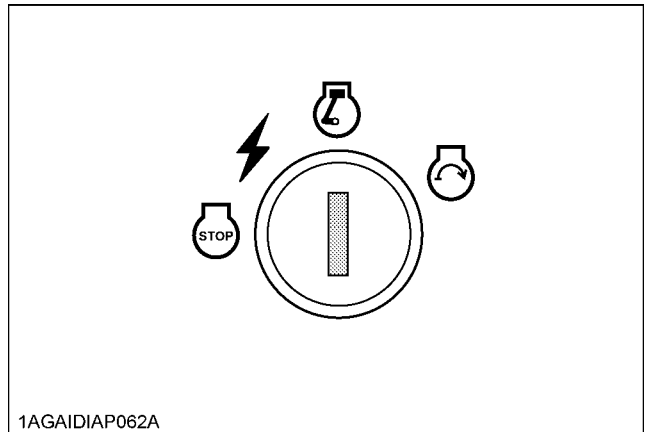

- ⏻ "STOP" "OFF" (Engine-Stop)
- ⚡ "ACC" (Electrical Power-accessories)
- 🔑 "ON" (Engine-Run)
- 🔑 "START" (Engine-Start)

NOTE:

- ACC...
- The accessories can be used while the engine is stopped.
 - Do not leave the key at "ACC" position. The battery will be quickly discharged. Turn it back to "OFF" after use.

◆ **Check Easy Checker(TM) Lamps:**

1. When the key is turned "ON", lamps (2) (3) should come on. If trouble should occur at any location while the engine is running, the indicator lamp corresponding to that location comes on.
2. Suppose that the engine coolant temperature is not high enough yet. The heater indicator (4) also comes on when the key is turned "ON" to preheat the engine and goes off automatically when preheat is completed. Illumination time of indicator varies according to the temperature of coolant
3. The PTO clutch indicator (1) comes on while PTO clutch control lever is engaged "ON" and goes off when disengaged "OFF" it.

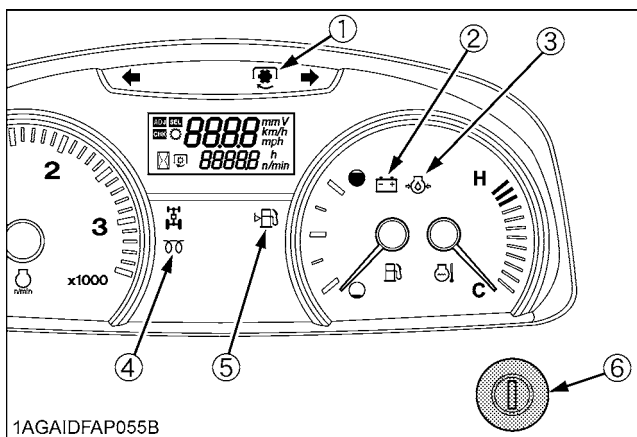

- | | |
|-----------------------------------|--------------------------|
| (1) PTO clutch indicator | (4) Heater indicator |
| (2) Electrical charge indicator | (5) Fuel level indicator |
| (3) Engine oil pressure indicator | (6) Key switch |

IMPORTANT :

- Daily checks with the Easy Checker(TM) only, are not sufficient. Never fail to conduct daily checks carefully by referring to Daily Check. (See "DAILY CHECK" in "PERIODIC SERVICE" section.)

7. Fully depress the clutch pedal.

8. Turn the key to "START" position and release when the engine starts.

IMPORTANT :

- Because of the safety devices, the engine will not start except when the PTO clutch control lever is placed in the "OFF" position and shuttle shift lever is placed in the "NEUTRAL" position.

9. Check to see that all the lamps on the Easy Checker(TM) are "OFF".

If a lamp is still on, immediately stop the engine and determine the cause.

10. Release the clutch pedal.

COLD WEATHER STARTING

If the ambient temperature is below 0 °C (32 °F) and the engine is very cold, follow the procedure below after taking the step 1 through 5 in the previous pages.

6. Turn the key to "ON" position and hold it until the heater indicator turns off.

Heater indicator comes on when the key is turned to "ON" position and engine coolant temperature is below 0 °C (32 °F), and goes off automatically when preheat is completed.

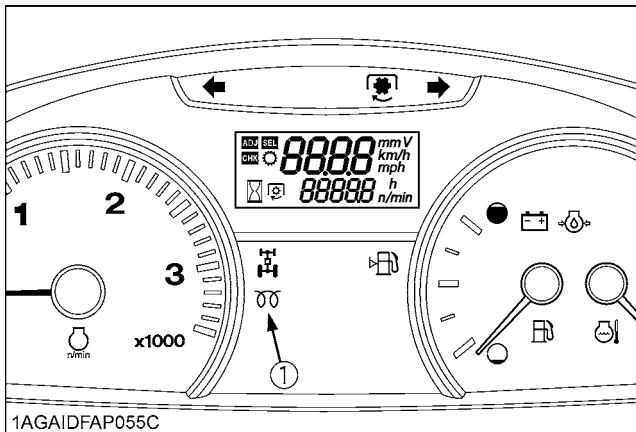

(1) Heater indicator

7. Fully depress the clutch pedal.

8. Turn the key to the "START" position and the engine should start.

(If the engine fails to start after 10 seconds, turn off the key for 30 seconds. Then repeat steps 6 through 8. To protect the battery and the starter, make sure that the starter is not continuously turned for more than 10 seconds.)

■ Block Heater (if equipped)

A block heater is available as an option from your dealer. It will assist you in starting your tractor when the ambient temperature is below -20 °C (-4 °F).

STOPPING THE ENGINE

1. After slowing the engine to idle, wait 3 to 5 minutes for turbo to slow down and then turn the key to "OFF".
2. Remove the key.

NOTE :

- If key does not stop the engine, consult your local KUBOTA Dealer.

WARMING UP



CAUTION

To avoid personal injury:

- Be sure to set the parking brake during warm-up.
- Be sure to set all shift levers to the "NEUTRAL" positions and to place PTO lever in "OFF" position during warm-up.

For five minutes after engine start-up, allow engine to warm up without applying any load, this is to allow oil to reach every engine part. If load should be applied to the engine without this warm-up period, trouble such as seizure, breakage or premature wear may develop.

■ Warm-up and Transmission Oil at Low Temperature Range

Hydraulic oil serves as transmission fluid. In cold weather, the oil may be cold with increased viscosity. This can cause delayed oil circulation or abnormally low hydraulic pressure for some time after engine start-up. This in turn can result in trouble in the hydraulic system.

To prevent the above, observe the following instructions: Warm up the engine at about 50 % of rated rpm according to the table below:

Ambient temperature	Warm-up time requirement
Higher than -10 °C (14 °F)	Approx. 10 minutes
-15 to -10 °C (5 to 14 °F)	10 to 20 minutes
-20 to -15 °C (-4 to 5 °F)	20 to 30 minutes
Below -20 °C (-4 °F)	More than 30 minutes

IMPORTANT :

- Do not operate the tractor under full load condition until it is sufficiently warmed up.

JUMP STARTING



CAUTION

To avoid personal injury:

- Battery gases can explode. Keep cigarettes, sparks, and flames away from battery.
- If tractor battery is frozen, do not jump start engine.
- Do not connect other end of negative (-) jumper cable to negative (-) terminal of tractor battery.

When jump starting engine, follow the instructions below to safely start the engine.

1. Bring helper vehicle with a battery of the same voltage as disabled tractor within easy cable reach. "THE VEHICLES MUST NOT TOUCH".
2. Engage the parking brakes of both vehicles and put the shift levers in neutral. Shut both engines off.
3. Put on safety goggles and rubber gloves.
4. Ensure the vent caps are securely in place. (if equipped)
5. Cover vent holes with damp rags. Do not allow the rag to touch the battery terminals.
6. Attach the red clamp to the positive (red, (+) or pos.) terminal of the dead battery and clamp the other end of the same cable to the positive (red, (+) or pos.) terminal of the helper battery.
7. Clamp the other cable to the negative (black, (-) or neg.) terminal of the helper battery.
8. Clamp the other end to the engine block or frame of the disabled tractor as far from the dead battery as possible.
9. Start the helper vehicle and let its engine run for a few moments. Start the disabled tractor.
10. Disconnect the jumper cables in the exact reverse order of attachment. (Steps 8, 7 and 6).
11. Remove and discard the damp rags.

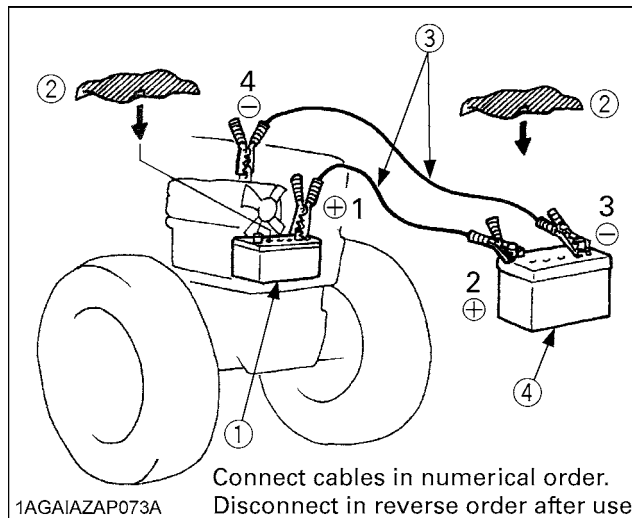

- (1) Dead battery
 (2) Lay a damp rag over the vent caps
 (3) Jumper cables
 (4) Helper battery

IMPORTANT :

- This machine has a 12 volt negative (-) ground starting system.
- Use only same voltage for jump starting.
- Use of a higher voltage source on tractor's electrical system could result in severe damage to tractor's electrical system.
 Use only matching voltage source when "Jump starting" a low or dead battery condition.

OPERATING THE TRACTOR

OPERATING NEW TRACTOR

How a new tractor is handled and maintained determines the life of the tractor.

A new tractor just off the factory production line has been, of course, tested, but the various parts are not accustomed to each other, so care should be taken to operate the tractor for the first 50 hours at a slower speed and avoid excessive work or operation until the various parts become "broken-in". The manner in which the tractor is handled during the "breaking-in" period greatly affects the life of your tractor.

Therefore, to obtain the maximum performance and the longest life of the tractor, it is very important to properly break-in your tractor. In handling a new tractor, the following precautions should be observed.

■ Do not Operate the Tractor at Full Speed for the First 50 Hours.

- Do not start quickly nor apply the brakes suddenly.
- In winter, operate the tractor after fully warming up the engine.
- Do not run the engine at speeds faster than necessary.
- On rough roads, slow down to suitable speeds. Do not operate the tractor at fast speed.

The above precautions are not limited only to new tractors, but to all tractors. But it should be especially observed in the case of new tractors.

■ Changing Lubricating Oil for New Tractors

The lubricating oil is especially important in the case of a new tractor. The various parts are not "broken-in" and are not accustomed to each other; small metal grit may develop during the operation of the tractor; and this may wear out or damage the parts. Therefore, care should be taken to change the lubricating oil a little earlier than would ordinarily be required.

For further details of change interval hours.

(See "MAINTENANCE" section.)

STARTING

1. Adjusting the Operator's Position.

■ Operator's Seat



CAUTION

To avoid personal injury:

- Make adjustments to the seat only while the tractor is stopped.
- Make sure that the seat is completely secured after each adjustment.
- Do not allow any person other than the operator to ride on the tractor.

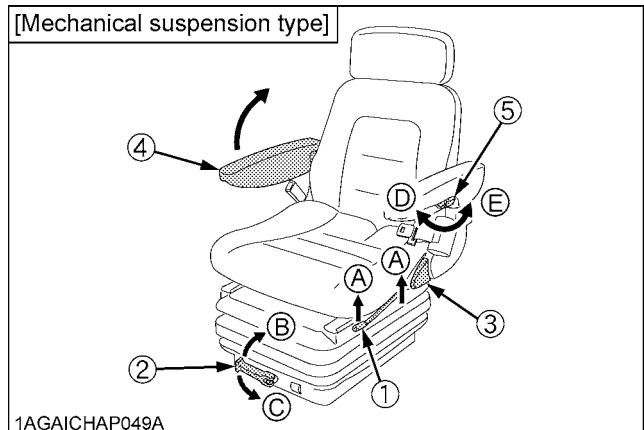

- | | |
|--------------------------------|---------------------------|
| (1) Travel adjust lever | (A) "UNLOCK" |
| (2) Weight adjust lever | (B) "TO INCREASE TENSION" |
| (3) Backrest tilt adjust lever | (C) "TO DECREASE TENSION" |
| (4) Arm rest | (D) "TO INCREASE ANGLE" |
| (5) Arm rest angle adjust knob | (E) "TO DECREASE ANGLE" |

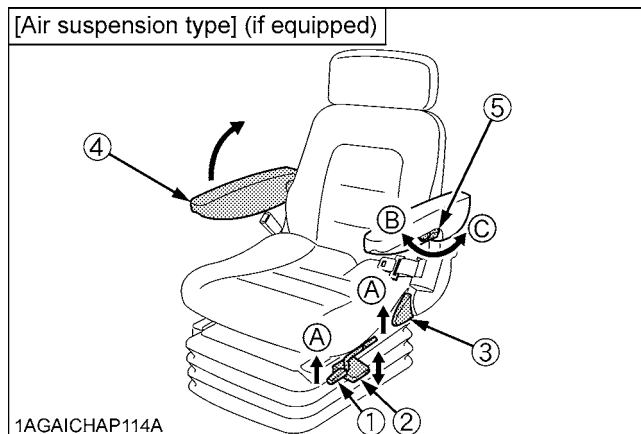

- | | |
|----------------------------------|-------------------------|
| (1) Travel adjust lever | (A) "UNLOCK" |
| (2) Weight / Height adjust lever | (B) "TO INCREASE ANGLE" |
| (3) Backrest tilt adjust lever | (C) "TO DECREASE ANGLE" |
| (4) Arm rest | |
| (5) Arm rest angle adjust knob | |

◆ Travel adjustment

Unlock the travel adjust lever and slide the seat backward or forward, as required. The seat will lock in position when the lever is released.

◆ Weight adjustment [Mechanical suspension type]

Turn the weight adjust lever to achieve the optimum suspension setting.

◆ Height adjustment [Mechanical suspension type]

Pull up with your hands the seat pan to the desired height of the three available positions.

Once it has reached the highest level, it will return to the lowest level.

◆ Weight and Height adjustment [Air suspension type] (if equipped)

The seat should be adjusted for the operator's weight by briefly pulling up or pushing down the actuator lever of the weight and height adjuster with the tractor in a stationary position and the operator sitting on the seat.

The operator must sit absolutely during adjustment.

IMPORTANT :

- In order to avoid damage of the seat, do not operate the actuator lever for more than 1 minute.

◆ Tilt adjustment

Pull the backrest tilt adjust lever and tilt the backrest to the desired position.

◆ Arm rest

Armrest may be set at upright position if desired.

◆ Arm rest angle adjustment

Turn the arm rest angle adjust knob to the desired angle.

IMPORTANT :

- After adjusting the operator's seat, be sure to check to see that the seat is properly locked,

■ Seat Belt



WARNING

To avoid personal injury:

- Always use the seat belt when any ROPS or CAB are installed.

Adjust the seat belt for proper fit and connect the buckle. This seat belt is auto-locking retractable type.

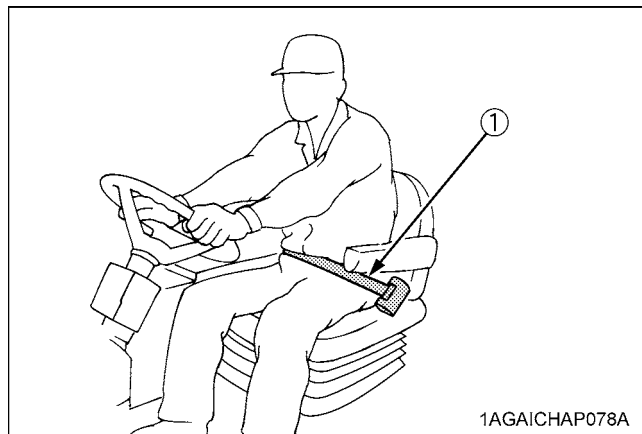

(1) Seat belt

■ Tilt Steering Adjustment



CAUTION

To avoid personal injury:

- Do not adjust the steering wheel while the tractor is in motion.

Press down the steering wheel tilt pedal, to release the lock so the steering wheel can be adjusted to one of 5 desired positions.

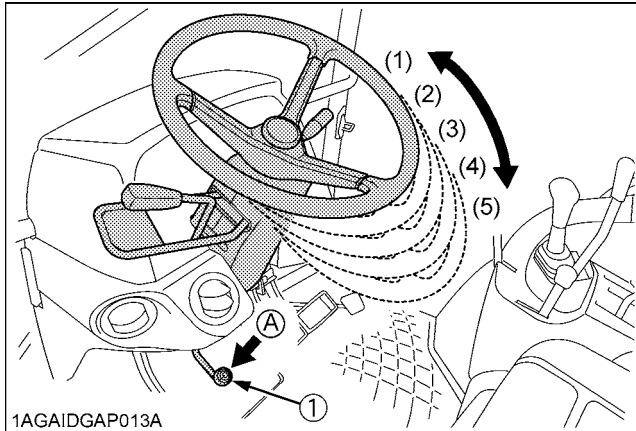



1AGAIDGAP013A

(1) Steering wheel tilt pedal (A) "PRESS DOWN"

2. Selecting Light Switch Positions.

■ Light Switch

Turn the light switch clockwise, and the following lights are activated on the switch position.

- OFF..... Head lights OFF.
- ..... Head lights dimmed, low beam.
- ..... Head lights ON, high beam.

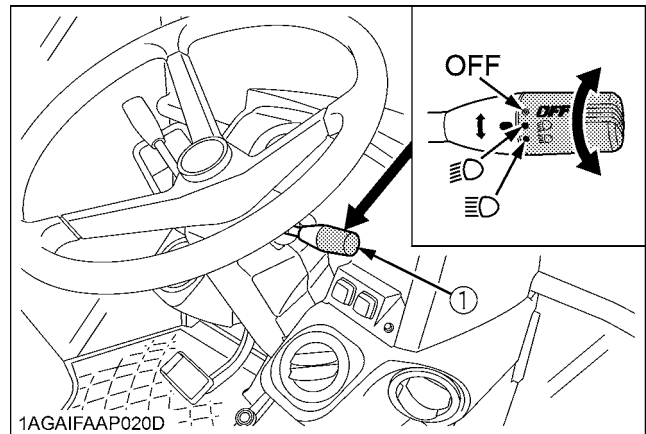

1AGAIFAAP020D

(1) Head light switch

■ Turn Signal / Hazard Light Switch

◆ Hazard Light

1. When the hazard light switch is pushed, the hazard lights flash, along with the L/H and R/H indicators on the instrument panel.
2. Push the hazard light switch again to turn off the hazard lights.

◆ Turn Signal with Hazard Light

1. To indicate a right turn with the hazard lights already flashing, turn the switch clockwise.
2. To indicate a left turn with the hazard lights already flashing, turn the switch counterclockwise.
3. When the left or right turn signal is activated in combination with the hazard lights, the indicated turning light will flash and the other will stay on.

◆ Turn Signal without Hazard Light

1. To indicate a right turn without hazard lights, turn the switch clockwise.
2. To indicate a left turn without hazard lights, turn the switch counterclockwise.
3. When the left or right turn signal is activated without the hazard lights, the indicated turning light will flash and the other will stay on.

NOTE :

- The hazard light switch is operative when the key switch is in either the "ON" or "OFF" position.
- The turn signal light switch is only operative when the key switch is in the "ON" position.
- Be sure to return the turn signal switch to center position after turning.

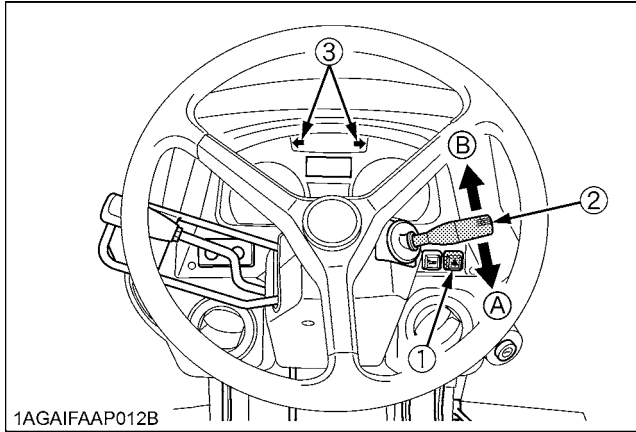

(1)Hazard light switch (A) "RIGHT TURN"
 (2)Turn signal light switch (B) "LEFT TURN"
 (3)Hazard / Turn signal indicator

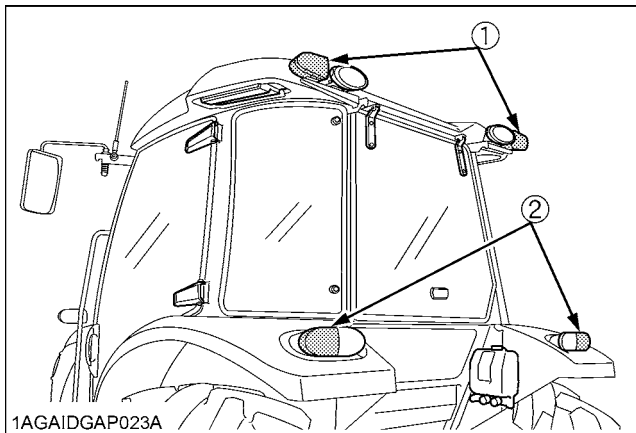

1AGAIDGAP023A

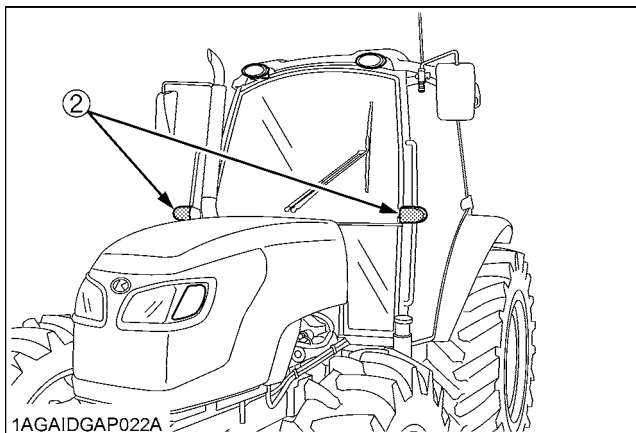

1AGAIDGAP022A

(1)Hazard light
 (2)Turn signal light

■Horn Button

The horn will sound when the key switch is "ON" position and horn button is pushed.

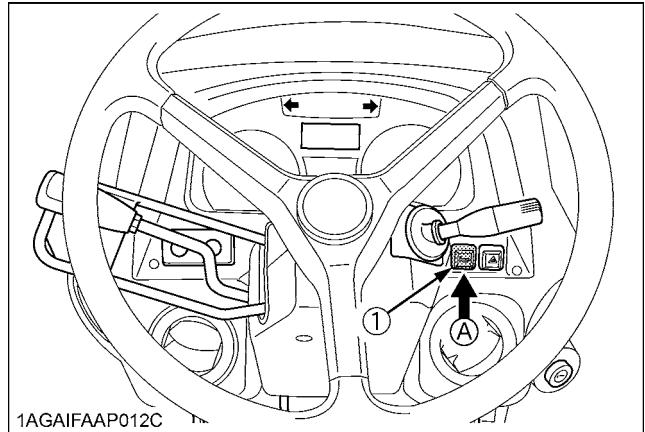

1AGAIFAAP012C

(1) Horn button (A) "PUSH"

3. Checking the Brake Pedal.

■Brake Pedals (Right and Left)



WARNING

To avoid personal injury:

- Be sure to interlock the right and left pedals. Applying only one rear wheel brake at high speeds could cause the tractor to swerve or roll-over.
- Be sure brake pedals have equal adjustment when using locked together. Incorrect or unequal brake pedal adjustment can cause the tractor to swerve or roll-over.



CAUTION

To avoid personal injury:

- Be aware of the enhanced braking characteristics of 4 wheel braking system. Appropriate care should be taken during hard braking and/or when pulling towed loads.
- Do not make sudden braking. An accident may occur such as by heavy towed load shifting forward or loss of control.
- To avoid skidding and less of steering control when driving on icy, wet, or loose surfaces, make sure the tractor is correctly ballasted, operated at reduced speed, operated with front wheel drive engaged (If equipped).
- The braking characteristics are different between two and four wheel drive. Be aware of the difference and use carefully.

1. Before operating the tractor on the road, be sure to interlock the right and left pedals as illustrated below.
2. Use individual brakes to assist in making sharp turns at slow speeds (Field Operation Only). Disengage the brake pedal lock and depress only one brake pedal.
3. Be sure brake pedals have equal adjustment when being used locked together.

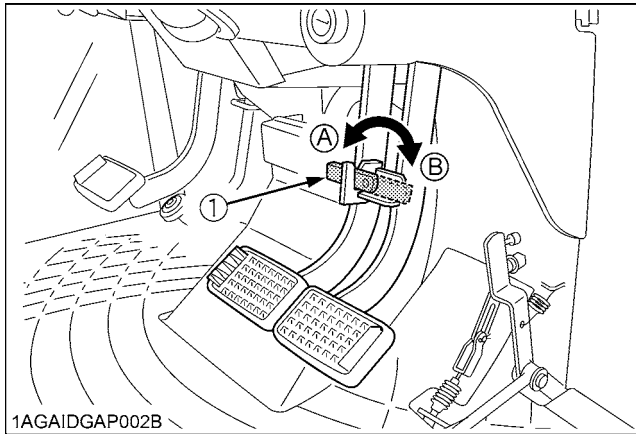

1AGAIDGAP002B

(1) Brake pedal lock

(A) "LOCK"

(B) "RELEASE"

4. Raise the Implement.
(see "HYDRAULIC UNIT" section.)

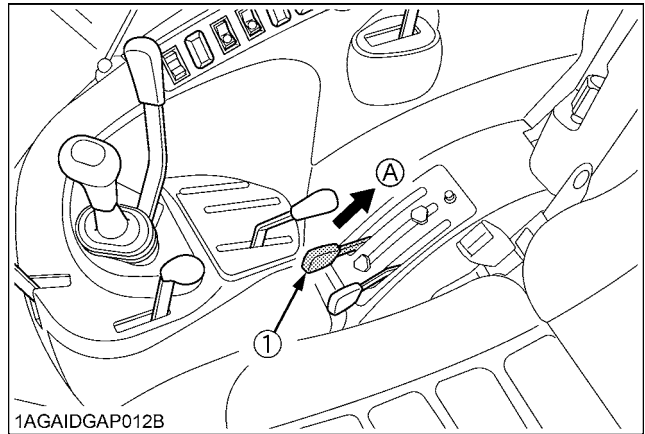

1AGAIDGAP012B

(1) Position control lever

(A) "UP"

◆ 4WD Braking System [Dual Speed model]

Dual speed model tractor is equipped with 4WD braking system.

When both brake pedals are applied together, the front axle is engaged for four wheel braking regardless of the mode selected at the 4WD switch.

When you step on the brake pedal while driving in 2WD mode, the "4WD braking system" gets activated and the 4WD indicator lights up.



WARNING

To avoid the possibility of personal injury or property damage from machine runaway during testing, service or repair with the rear wheels off the ground, make sure:

- Battery is disconnected and engine is not started.

If it is necessary to run the engine, make sure:

- Both front and rear wheels are off the ground and secured with stands before starting engine.

5. Depress the Clutch Pedal.

■ Clutch Pedal



CAUTION

To avoid personal injury:

- Sudden release of the clutch may cause the tractor to lunge in an unexpected manner.

The clutch is disengaged when the clutch pedal is fully pressed down.

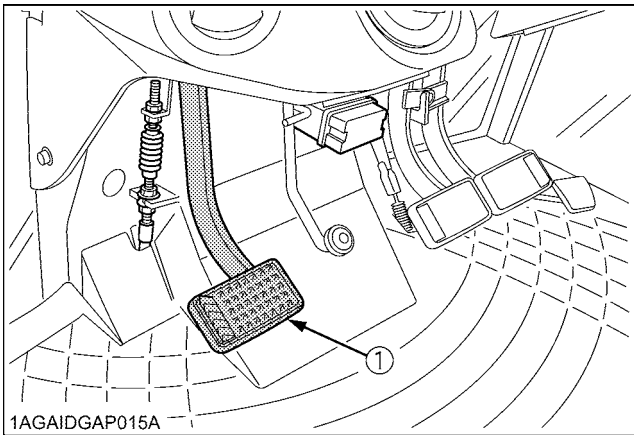

(1) Clutch pedal

IMPORTANT :

To help prevent premature clutch wear:

- The clutch pedal must be quickly disengaged and be slowly engaged.
- Avoid operating the tractor with your foot resting on the clutch pedal.
- Select proper gear and engine speed depending on the type of job.

6. Selecting the Travel Speed.

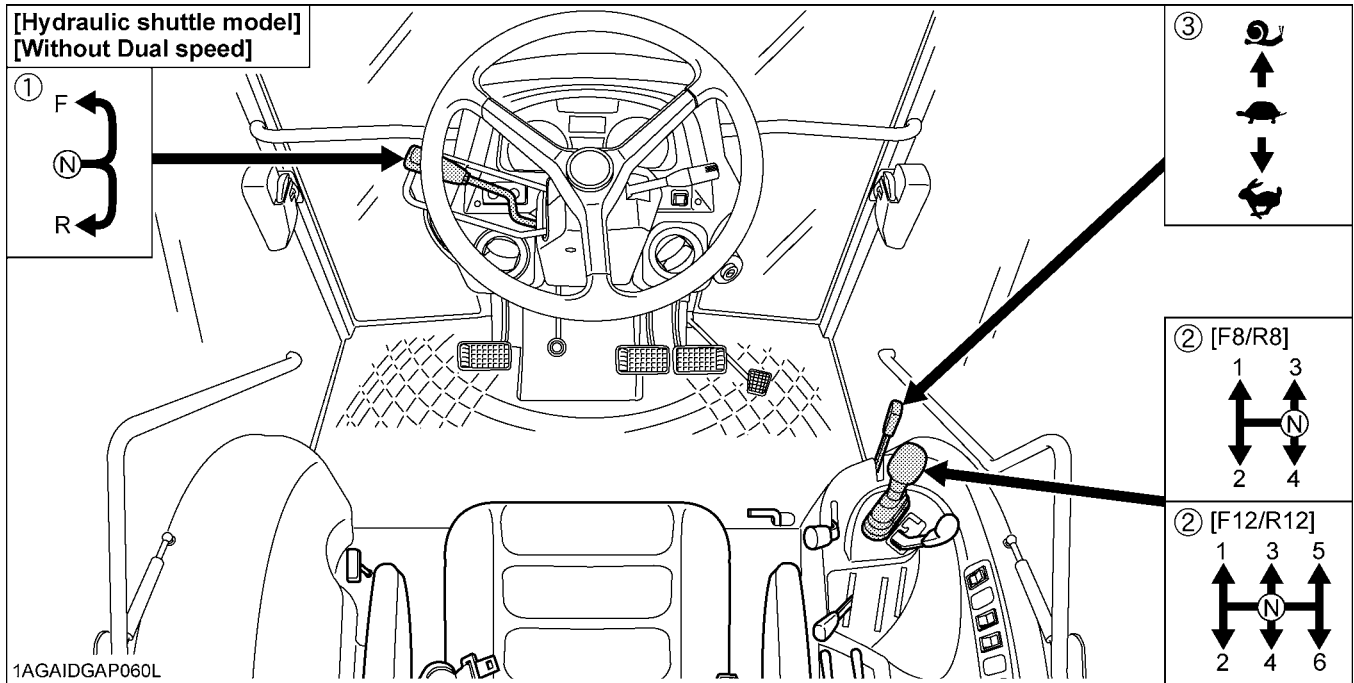

- (1) Hydraulic - shuttle shift lever
- (2) Main gear shift lever
- (3) Range gear shift lever

- (F) "FORWARD"
- (N) "NEUTRAL POSITION"
- (R) "REVERSE"

- ☛ "LOW"
- ☜ "HIGH"
- ☞ "CREEP" (if equipped)

By combination of using the main gear shift lever, the range gear shift lever and hydraulic-shuttle shift lever, forward speeds and reverse speeds shown in the table below are obtained.

Standard model (F8 / R8 model)	Without creep	8 forward speeds 8 reverse speeds
	With creep	12 forward speeds 12 reverse speeds
F12 / R12 model	Without creep	12 forward speeds 12 reverse speeds
	With creep	18 forward speeds 18 reverse speeds

■ Main Gear Shift Lever

The main gear shift is fully synchronized to shift without stopping.

IMPORTANT :

- The main gear shift may be shifted between speeds on-the-go, but the clutch must be depressed.

■ Range Gear Shift Lever

The range gear shift can only be shifted when the tractor is completely stopped and the clutch is depressed.

IMPORTANT :

- To avoid transmission damage, depress clutch pedal and stop the tractor before shifting between ranges.

■ Hydraulic-Shuttle Shift Lever

Raise up and shift the shuttle shift lever forward to obtain forward speeds and shift back to obtain reverse speeds. This shifting does not require clutch operation.

IMPORTANT :

- The hydraulic-shuttle shift lever may be shifted while the tractor is moving slowly.

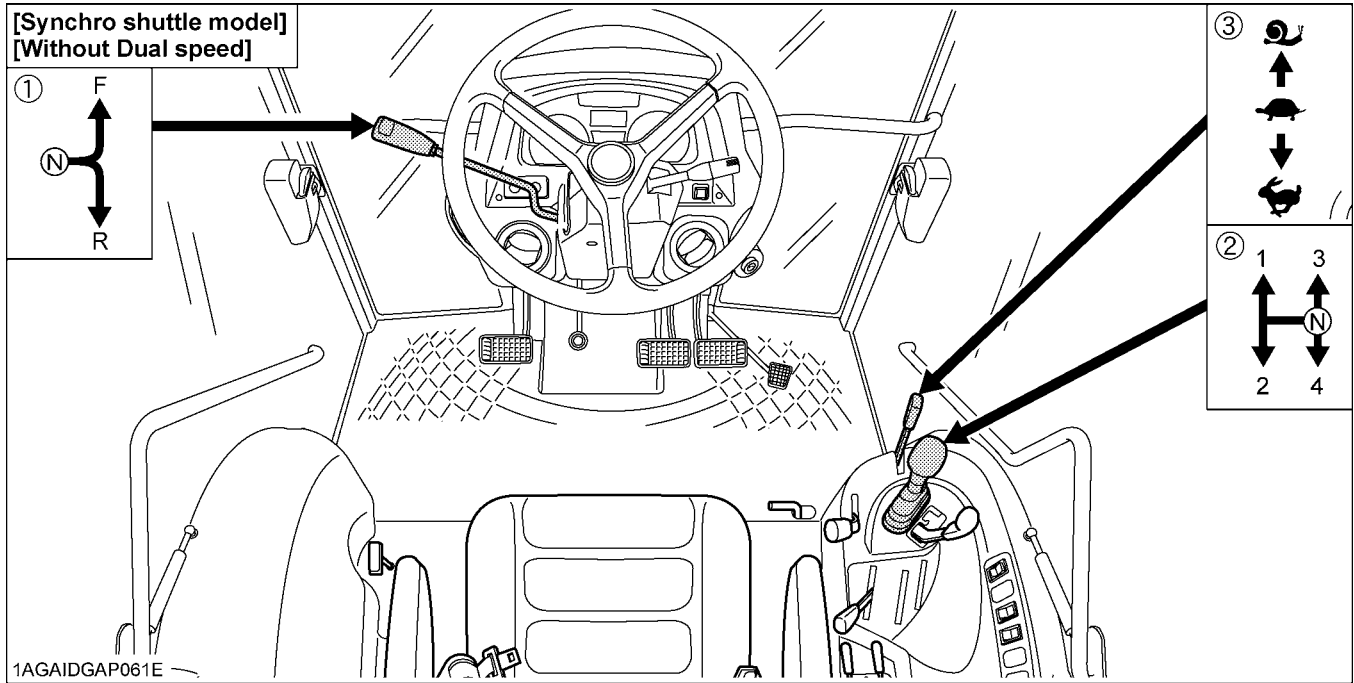

(1) Synchro - shuttle shift lever
 (2) Main gear shift lever
 (3) Range gear shift lever

(F) "FORWARD"
 (N) "NEUTRAL POSITION"
 (R) "REVERSE"

☛ "LOW"
 ☛ "HIGH"
 ☛ "CREEP" (if equipped)

By combination of using the main gear shift lever, the range gear shift lever and synchro-shuttle shift lever, forward speeds and reverse speeds shown in the table below are obtained.

Standard model (F8 / R8 model)	Without creep	8 forward speeds 8 reverse speeds
	With creep	12 forward speeds 12 reverse speeds

■ Main Gear Shift Lever

The main gear shift is fully synchronized to shift without stopping.

IMPORTANT :

- The main gear shift may be shifted between speeds on-the-go, but the clutch must be depressed.

■ Range Gear Shift Lever

The range gear shift can only be shifted when the tractor is completely stopped and the clutch is depressed.

IMPORTANT :

- To avoid transmission damage, depress clutch pedal and stop the tractor before shifting between ranges.

■ Synchro-Shuttle Shift Lever

Raise up and shift the shuttle shift lever forward to obtain forward speeds and shift back to obtain reverse speeds. This shifting requires clutch operation.

IMPORTANT :

- The synchro-shuttle shift lever may be shifted while the tractor is moving slowly and the clutch is depressed, but sudden gear shift may cause transmission damage.

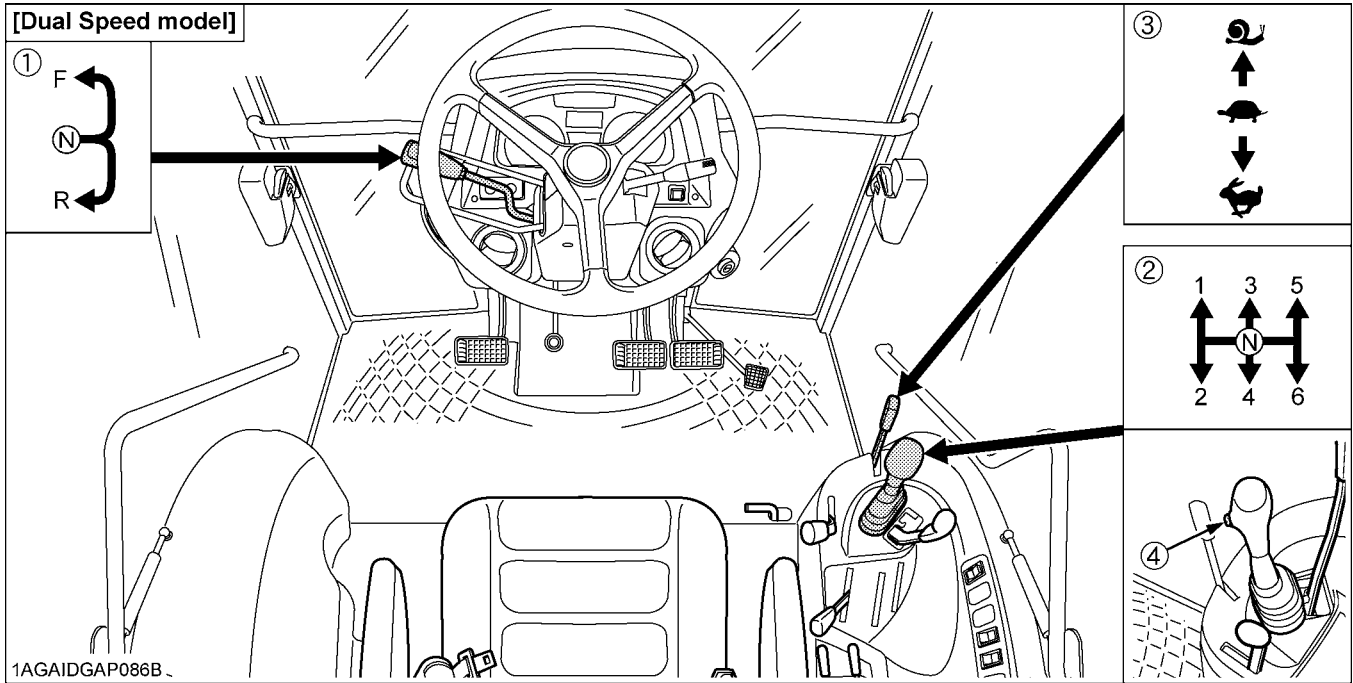

1AGAIDGAP086B

- (1) Hydraulic - shuttle shift lever
- (2) Main gear shift lever
- (3) Range gear shift lever
- (4) Dual speed shift switch

- (F) "FORWARD"
- (N) "NEUTRAL POSITION"
- (R) "REVERSE"

- ↔ "LOW"
- ↔ "HIGH"
- ↻ "CREEP" (if equipped)

By combination of using the main gear shift lever, dual speed shift switch, the range gear shift lever and hydraulic-shuttle shift lever, forward speeds and reverse speeds shown in the table below are obtained.

Standard model (F24 / R24 model)	Without creep	24 forward speeds 24 reverse speeds
	With creep	36 forward speeds 36 reverse speeds

■ Main Gear Shift Lever

The main gear shift is fully synchronized to shift without stopping.

IMPORTANT :

- The main gear shift may be shifted between speeds on-the-go, but the clutch must be depressed.

■ Range Gear Shift Lever

The range gear shift can only be shifted when the tractor is completely stopped and the clutch is depressed.

IMPORTANT :

- To avoid transmission damage, depress clutch pedal and stop the tractor before shifting between ranges.

■ Hydraulic-Shuttle Shift Lever

Raise up and shift the shuttle shift lever forward to obtain forward speeds and shift back to obtain reverse speeds. This shifting does not require clutch operation.

IMPORTANT :

- The hydraulic-shuttle shift lever may be shifted while the tractor is moving slowly.

■ Dual Speed Shift Switch

[Dual speed model]

The dual speed shift switch can be operated when the tractor is traveling without using the clutch.

(This switch effects tractor travel speed change by about 19%). "LO" speed and "HI" speed change at each time this switch is pushed.

◆ Dual Speed Indicator

The indicator comes on when the dual speed switch is set to "LO".

The indicator goes off when the dual speed switch is set to "HI".

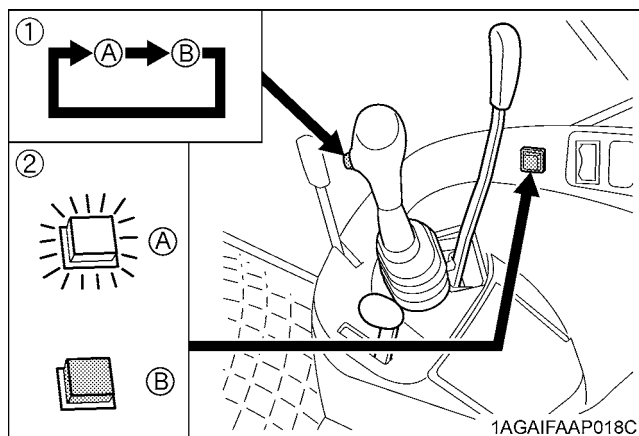

(1) Dual speed shift switch
(2) Dual speed indicator

(A) "LO"
(B) "HI"

■ Creep Speed (if equipped)

Shift the range gear shift lever to  to obtain low speeds.

This shifting requires clutch operation.

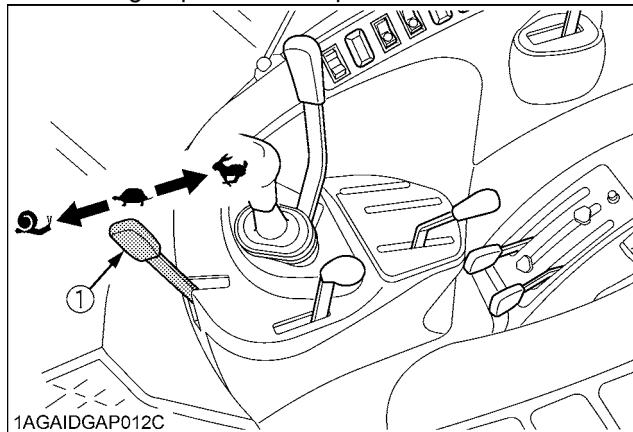

(1) Range gear shift lever  ...Creep ON

◆ Creep speed should be used only when doing one of the following jobs:

1. Deep rotary-tilling and harrowing
2. Planting
3. Turf application

◆ Creep speed can not be used for any of the followings:

1. Pulling a trailer
2. Front-loader operation
3. Front-blade operation
4. Earth-moving
5. Entering and leaving a field
6. Loading onto and unloading from a truck



CAUTION

To avoid personal injury:

- When you leave the tractor, be sure to apply the parking brake and stop the engine.
- IN APPLYING THE BRAKES:
 - The torque of the wheel axle is extremely high while creep speed is being used. Be sure to step down on the clutch pedal completely before applying the brakes, or they will not work
 - When starting to operate the tractor, be sure to release the parking brakes.
Misuse of the brakes may cause damage to the transmission and is therefore not acceptable to KUBOTA for coverage under the warranty.

IMPORTANT :

- Press the clutch pedal completely down and stop the tractor's motion before shifting the range gear shift lever.

■ Front Wheel Drive Lever

[Without Dual Speed model]



CAUTION

To avoid personal injury:

- Do not engage the front wheel drive when traveling at road speed.
- When driving on icy, wet, or loose surfaces, make sure the tractor is correctly ballasted to avoid skidding and loss of steering control. Operate at reduced speed and engage front wheel drive.
- An accident may occur if the tractor is suddenly braked, such as by heavy towed loads shifting forward or loss of control.
- The braking characteristics are different between two and four wheel drive. Be aware of the difference and use carefully.

The front wheel drive lever can be operated with the tractor moving slowly and with the engine decelerating without clutch operation. Shift the lever to "ON" to engage the front wheel drive.

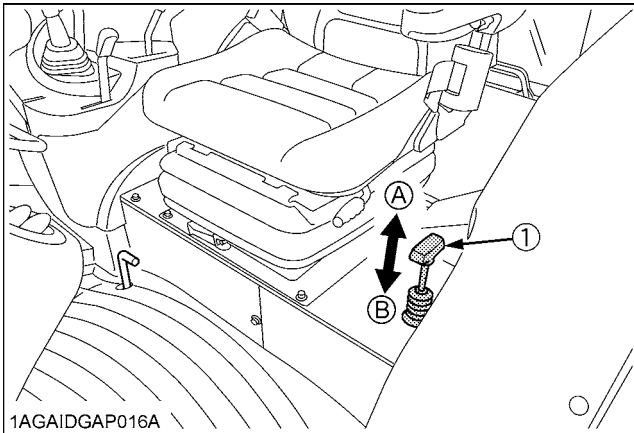

(1) Front wheel drive lever

(A) "ON"

(B) "OFF"

◆ 4WD Indicator

The 4WD indicator turns on while the front wheel drive lever is in "ON" (4WD) position.

The 4WD indicator goes off when the front wheel drive lever is in "OFF" (2WD) position.

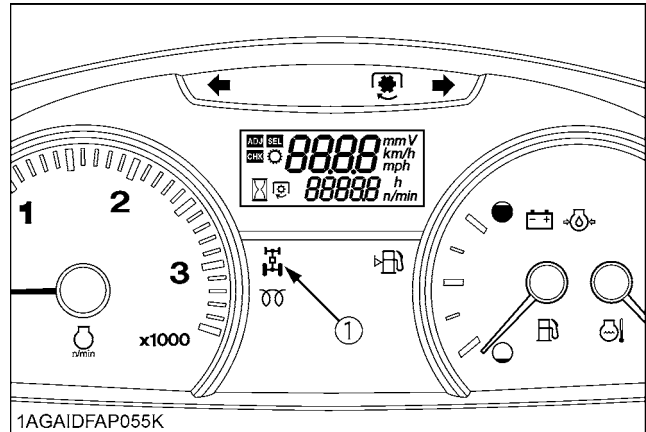

(1) 4WD indicator

NOTE :

- Even when the front wheel drive lever is moved, the 4WD indicator may fail to light up or go out immediately. Just keep on running the tractor, and the indicator will light up or go out accordingly. If the indicator fails to come on or off with the tractor at a stop, turn the steering wheel clockwise and counterclockwise, and the indicator will light up or go out accordingly.

IMPORTANT :

- Tires will wear quickly if front wheel drive is engaged on paved roads.
- Reduce the rear wheels traction before engaging the front wheel drive lever.

◆ Front wheel drive is effective for the following jobs:

1. When greater pulling force is needed, such as working in a wet field, when pulling a trailer, or when working with a front-end loader.
2. When working in sandy soil.
3. When working on a hard soil where a rotary tiller might push the tractor forward.
4. For increased braking at reduced speed.

■ 4WD Switch

[With Dual Speed model]



CAUTION

To avoid personal injury:

- Do not engage the front wheel drive when traveling at road speed.
- When driving on icy, wet, or loose surfaces, make sure the tractor is correctly ballasted to avoid skidding and loss of steering control. Operate at reduced speed and engage front wheel drive.
- 4WD model tractor is equipped with 4 wheel braking and appropriate care should be taken during hard braking.
- An accident may occur if the tractor is suddenly braked, such as by heavy towed loads shifting forward or loss of control.
- The braking characteristics are different between two and four wheel drive tractor models. Be aware of the difference and use carefully.

Press the bottom half of this switch;

The front wheel drive (4WD) is engaged.

The switch with indicator and 4WD indicator come on when the system is in 4WD mode.

Press the top half of this switch;

The drive system returns to 2WD mode.

The all indicators goes off when the system is in 2WD mode.

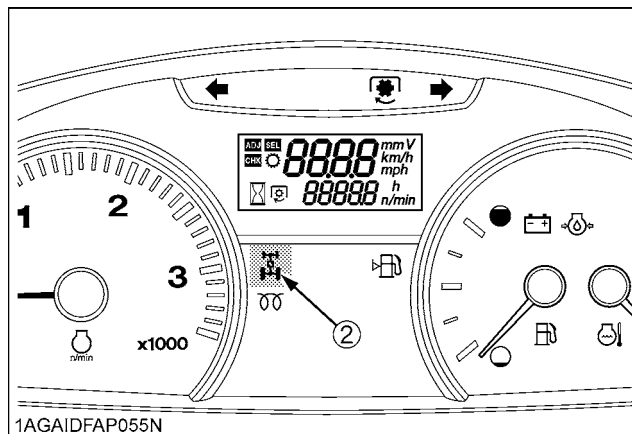
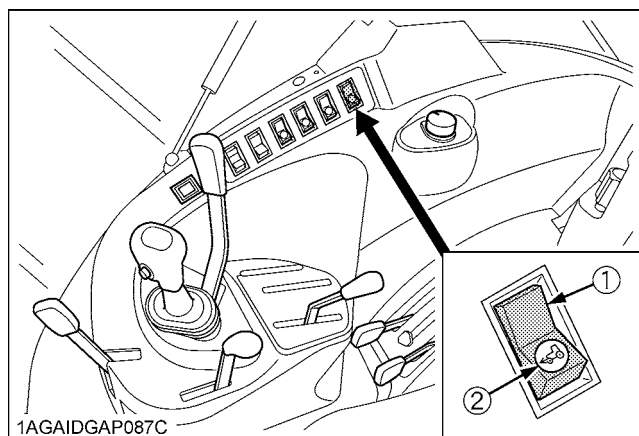

(1) 4WD switch with indicator

(2) 4WD indicator

◆ Front wheel drive is effective for the following jobs:

1. When greater pulling force is needed, such as working in a wet field, when pulling a trailer, or when working with a front-end loader.
2. When working in sandy soil.
3. When working on a hard soil where a rotary tiller might push the tractor forward.

IMPORTANT :

- Tires will wear quickly if the front wheel drive is engaged on paved roads.

7. Accelerate the Engine.

■ Hand Throttle Lever

Pulling the throttle lever back decreases engine speed, and pushing it forward increases engine speed.

■ Foot Throttle

Use the foot throttle when traveling on the road. Press down on it for higher speed. The foot throttle is interlocked with the hand throttle lever; when using the foot throttle, keep the hand throttle lever in low idling position.

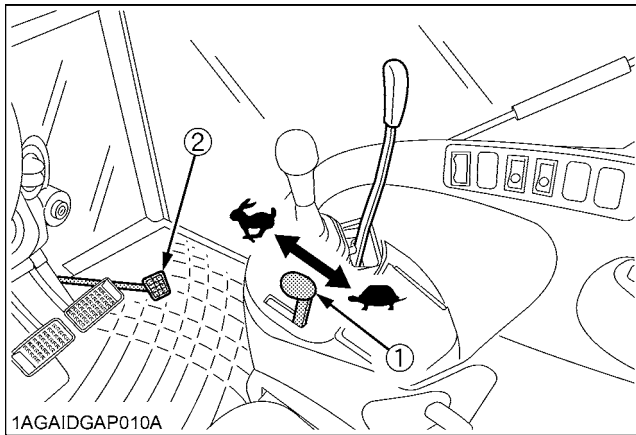

(1) Hand throttle lever
(2) Foot throttle

▲ "INCREASE"
▼ "DECREASE"

8. Unlock the Parking Brake and Slowly Release the Clutch.

■ Parking Brake Lever

To release the parking brake, depress the brake pedals and shift the lever to transport position.

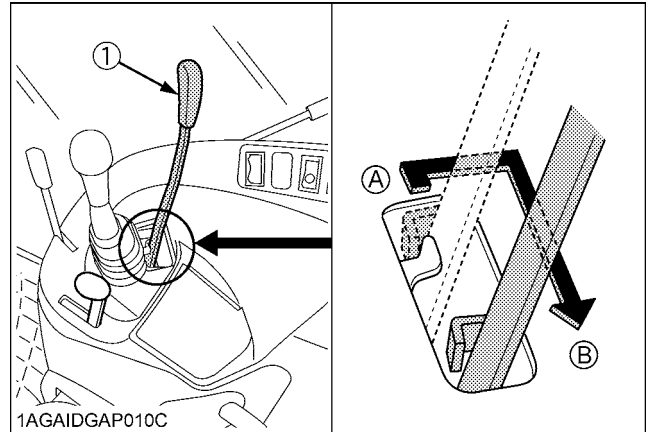

(1) Parking brake lever

(A) "PARKING POSITION"
(B) "TRANSPORT POSITION"

IMPORTANT :

- When setting the parking brake, shift the main gear shift lever to "N" position. (The parking brake can be set only when the main gear shift lever is at the "N" position.)
- When shifting the main gear shift lever, shift the parking brake lever to transport position. (The main gear shift lever can be shifted only when the parking brake lever is at transport position.)

NOTE :

- In moving the parking brake lever, you may feel it heavy some time or light other time. This is not a trouble, however.

STOPPING

■ Stopping

1. Slow down the engine.
2. Step on the clutch and brake pedal.
3. After the tractor has stopped, disengage the PTO, lower the implement to the ground, shift the transmission to neutral, release the clutch pedal, and set the parking brake.

CHECK DURING DRIVING

■ Immediately Stop the Engine if:

- The engine suddenly slows down or accelerates,
- Unusual noises are suddenly heard,
- Exhaust fumes suddenly become very dark,

■ Easy Checker(TM)

If the warning lamps in the Easy Checker(TM) come on during operation, immediately stop the engine, and find the cause as shown below.

Never operate the tractor while Easy Checker(TM) lamp is on.

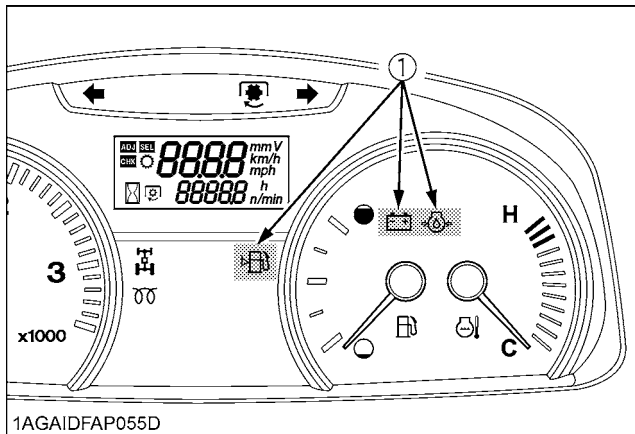

(1) Easy Checker(TM)

⚠ Engine oil pressure

If the oil pressure in the engine goes below the prescribed level, the warning lamp in the Easy Checker(TM) will come on.

If this should happen during operation, and it does not go off when the engine is accelerated to more than 1000 rpm, check level of engine oil.

(See "Checking Engine Oil Level" in "DAILY CHECK" in "PERIODIC SERVICE" section.)

⚠ Fuel level

If the fuel in the tank goes below the prescribed level, the warning lamp in the Easy Checker(TM) will come on. (less than 15 L (4.0 gals.))

If this should happen during operation, refuel as soon as possible.

(See "Checking and Refueling" in "DAILY CHECK" in "PERIODIC SERVICE" section.)

⚠ Electrical charge

If the alternator is not charging the battery, the Easy Checker(TM) will come on.

If this should happen during operation, check the electrical charging system or consult your local KUBOTA Dealer.

NOTE :

- For checking and servicing of your tractor, consult your local KUBOTA Dealer for instructions.

■ Fuel Gauge

When the key switch is on, the fuel gauge indicates the fuel level.

Be careful not to empty the fuel tank. Otherwise air may enter the fuel system.

Should this happen, the system should be bled (See "Bleeding Fuel System" in "SERVICE AS REQUIRED" in "PERIODIC SERVICE" section.)

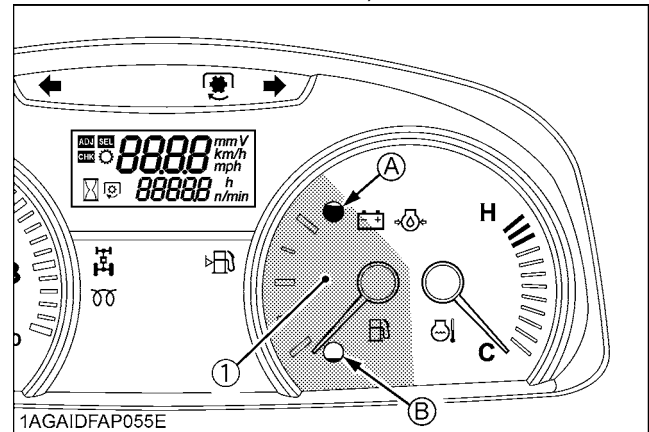

(1) Fuel gauge

(A) "FULL"

(B) "EMPTY"

■ Coolant Temperature Gauge



CAUTION

To avoid personal injury:

- Do not remove radiator cap until coolant temperature is well below its boiling point. Then loosen cap slightly to the stop to relieve any pressure before removing cap completely.

1. With the key switch at "ON", this gauge indicates the temperature of the coolant. "C" for "cold" and "H" for "hot."
2. If the indicator reaches the "H" position (red zone), engine coolant is overheated. Check the tractor by referring to "TROUBLESHOOTING" section.

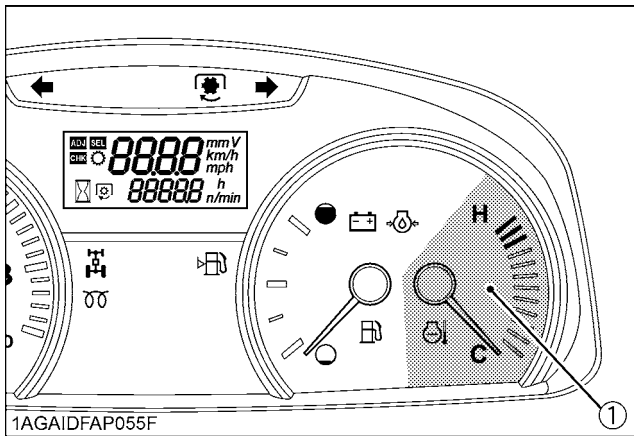

(1) Coolant temperature gauge

■ Tachometer

The tachometer indicates the engine speed on the dial.

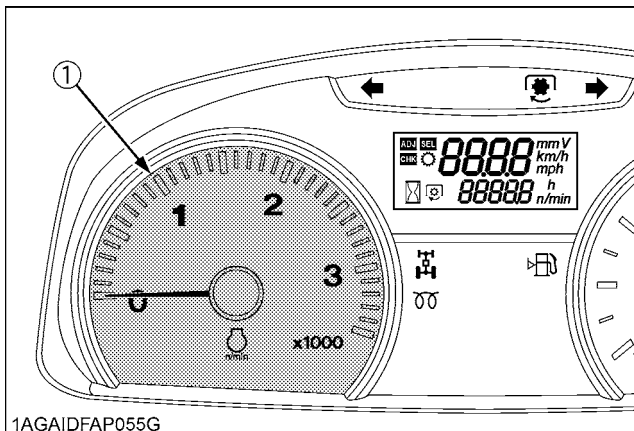

(1) Engine revolution







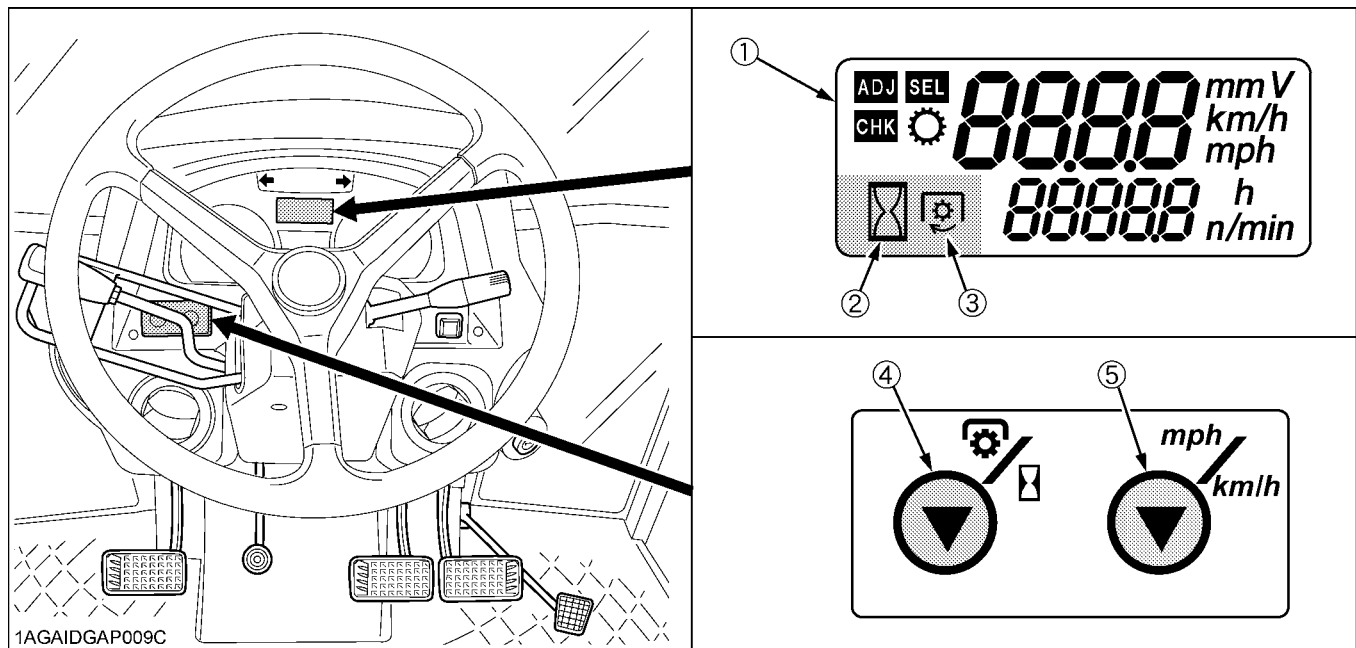

PTO RPM / TRAVEL SPEED MONITOR

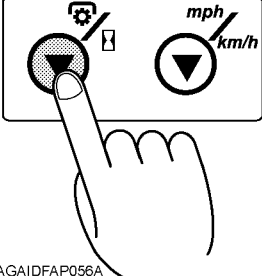
■ Changing Display Mode

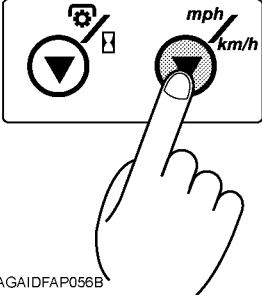
1. The LCD monitor gives two different display modes: "Traveling speed and Hour meter" and "Traveling speed and PTO speed". Each time the PTO/Hour meter select switch is pressed, the mode is switched to the changing display.
2. To switch between "mph" and "km/h" for the traveling speed, use the Traveling speed select switch.
3. The PTO clutch control switch or lever works for the following automatic display modes.
 - 1) PTO clutch control switch or lever ON: Traveling speed and PTO speed are displayed.
 - 2) PTO clutch control switch or lever OFF: Traveling speed and Hour meter are displayed.

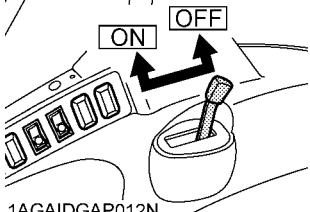

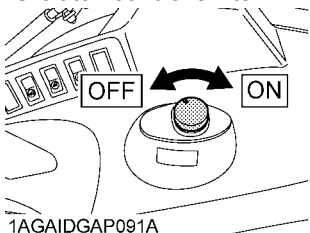
- (1) LCD monitor
- (2) Hour Meter indication
- (3) PTO Indication
- (4) PTO / Hour Meter Select Switch
- (5) Traveling Speed Select Switch

<p>1</p> <p>Display mode switching [Hour meter mode] and [PTO speed mode]</p>  <p>1AGAIDFAP056A</p>	<p>Hour meter mode</p>  <p>1AGAIDFAP072A</p>	<ul style="list-style-type: none"> ● Traveling speed and total operating hours are displayed. ● The hour meter indicates in five digits the hours the tractor has been used; the last digit indicates 1/10 of an hour.
<p>2</p> <p>Display mode switching [km/h] and [mph]</p>  <p>1AGAIDFAP056B</p>	<p>mph (Traveling speed)</p>  <p>1AGAIDFAP072D</p>	
<p>km/h (Traveling speed)</p>  <p>1AGAIDFAP072C</p>		
<p>3</p> <p>PTO clutch control lever</p>  <p>1AGAIDGAP012N</p>	<p>PTO OFF (Hour meter mode)</p>  <p>1AGAIDFAP072A</p>	<ul style="list-style-type: none"> ● Traveling speed and total operating hours are displayed. ● The hour meter indicates in five digits the hours the tractor has been used; the last digit indicates 1/10 of an hour. ● When the PTO / Hour meter select switch is pressed in this state, "OFF" is displayed.
<p>PTO clutch control switch</p>  <p>1AGAIDGAP091A</p>	<p>PTO ON (PTO speed mode)</p>  <p>1AGAIDFAP072E</p>	<ul style="list-style-type: none"> ● Traveling speed and PTO speed are displayed. ● When the PTO / Hour meter select switch is pressed in this state, the display mode switches to hour meter mode.

NOTE :

- The travel speed displayed when the wheels slip under traction is different from the actual one.
- In cold weather the LCD monitor response will normally be slower and the visibility be less, than in warmer weather.

■ PTO Speed Display Mode Switching

Whenever the PTO speed is changed to the other speed, it is necessary to switch the PTO speed display mode. Otherwise the PTO speed will not get correctly displayed in the LCD monitor. When the PTO speed is changed from 540 rpm to 1000 rpm or from 1000 rpm to 540 rpm, it is necessary to switch the PTO speed display mode.

◆ Switching procedure

- ① While pressing the PTO/Hour meter select switch, turn the key switch to "ON" position.

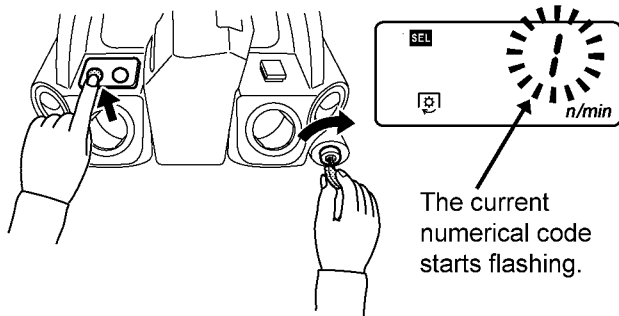

- ② Each time the PTO/Hour meter select switch is pressed, the code changes in the order of [1]→[2]→[3]→[4]→[5]→[1]. Select the appropriate code according to the table below.

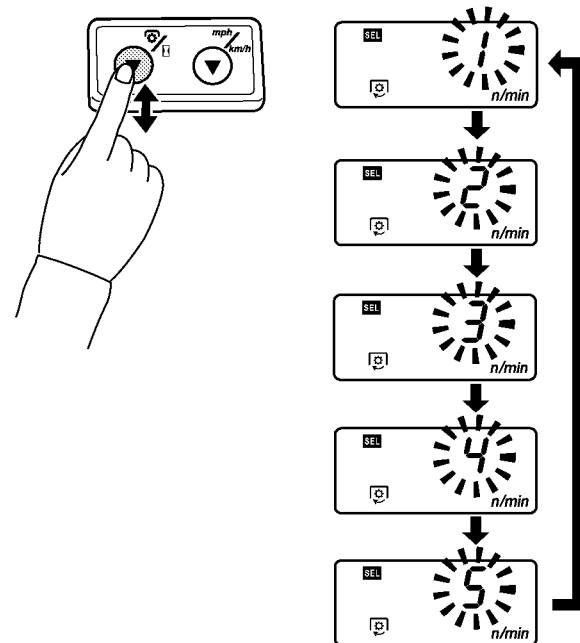

- ③ Press and hold the PTO/Hour meter select switch longer than 2 seconds. The setting is put in memory, and the LCD monitor goes back to the PTO speed display mode.

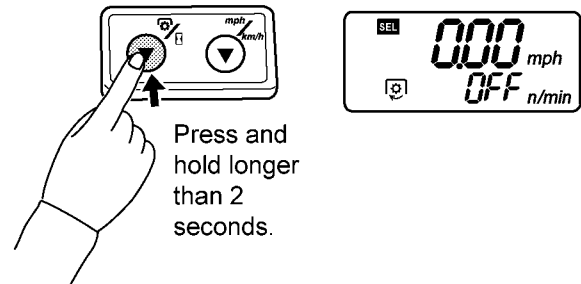

NOTE:

- The setting will be cancelled if the key switch is turned OFF halfway in the procedure.

Numerical code	PTO speed (rpm)
1	540 (Standard)
2	540 (Dual Speed PTO Kit)
3	1000 (Dual Speed PTO Kit)
4	Not select (North America model)
5	

■ Entering the Travel Speed Coefficient

When optional different-diameter tires are fitted on the machine, the travel speed display mode must be changed. Otherwise the travel speed will not get correctly displayed. Such mode switching is also needed when the original tires are back on the machine.

◆ How to enter the tire circumference

Example: Entering 179.0 inch.

① While pressing the Traveling speed select switch, turn the key switch to ON position. The setting of the current tire's circumference is displayed in inches or millimeters. The highest-digit numeral starts flashing.

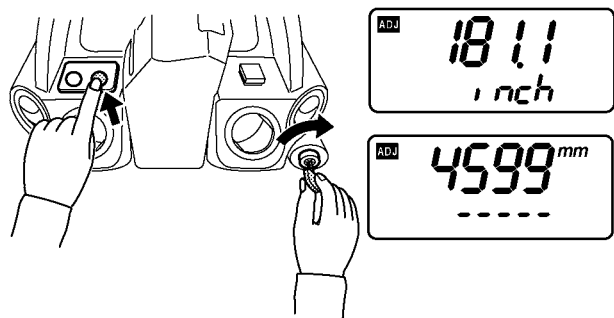

② Each time both the PTO/Hour meter select switch and Traveling speed select switch are pressed at the same time, the unit changes for inches or millimeters. Select the inch display mode.

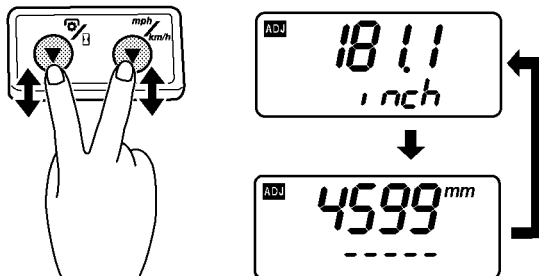

③ Note that the highest-digit numeral is flashing. Press the PTO/Hour meter select switch to select "1". (The numeral changes from 0 to 9 at each push of the switch.)

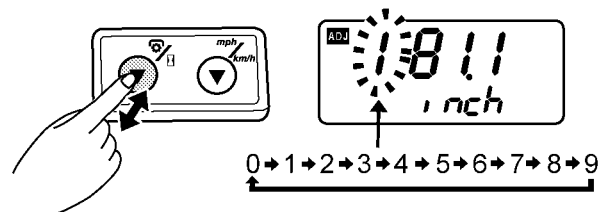

④ Press the Traveling speed select switch, and the next highest digit starts flashing.

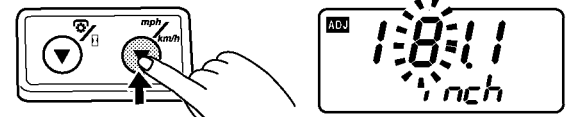

Now press the PTO/Hour meter select switch to select "7".

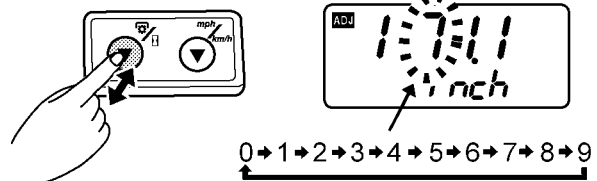

⑤ Enter "9" and "0" for the remaining digits in the same procedure.

⑥ Make sure the entry is "179.0". Press and hold the Traveling speed select switch longer than 2 seconds. The setting is put in memory, and the LCD monitor goes back to the Hour meter mode.

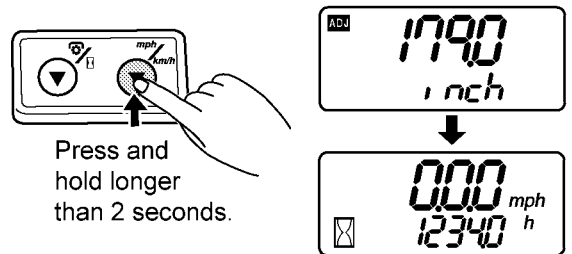

NOTE:

- The setting will be cancelled if the key switch is turned OFF halfway in the procedure.

◆ **Tire circumference chart (reference)**

Rear tire size	Entry (in.)	Entry (mm)
16.9-24 LowProfile	152.0	3861
19.5L-24 R4 IND	154.0	3912
18.4-26 R3 Turf	167.0	4242
18.4-26 R1	173.7	4411
18.4-28 R1	175.0	4445
18.4-30 R1	179.0	4546
18.4R30	183.3	4656
16.9-34 R1	184.0	4674

PARKING

■ Parking

Hydraulic Shuttle model



CAUTION

To avoid personal injury:

BEFORE DISMOUNTING TRACTOR

- ALWAYS SET PARKING BRAKE AND LOWER ALL IMPLEMENTS TO THE GROUND.

Leaving transmission in gear with the engine stopped will not prevent the tractor from accidental rolling.

- STOP THE ENGINE AND REMOVE THE KEY.

Synchro Shuttle model



CAUTION

To avoid personal injury:

BEFORE DISMOUNTING TRACTOR

- ALWAYS SET PARKING BRAKE AND LOWER ALL IMPLEMENTS TO THE GROUND.
- STOP THE ENGINE AND REMOVE THE KEY.

1. Before getting off the tractor, disengage the PTO, lower all implements, place all control levers in their neutral positions, push the parking brake lever to parking position, stop the engine and remove the key.
2. If it is necessary to park on an incline, be sure to chock the wheels to prevent accidental rolling of the machine.

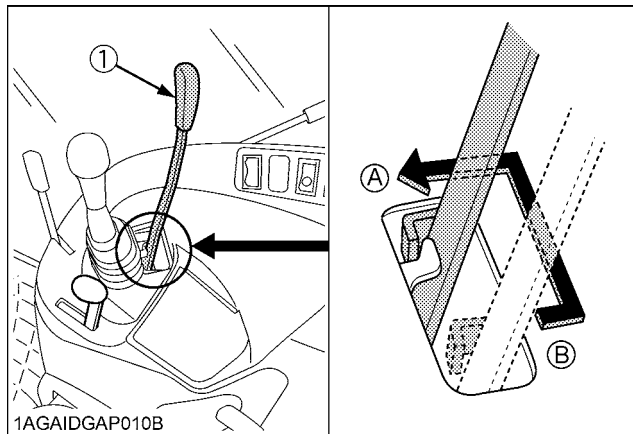

(1) Parking brake lever

(A) "PARKING POSITION"

(B) "TRANSPORT POSITION"

IMPORTANT :

- Do not leave your tractor in the rain. If it cannot be avoided, cover the muffler pipe to prevent water entering.

OPERATING TECHNIQUES

■ Differential Lock



WARNING

To avoid personal injury due to loss of steering control:

- Do not operate the tractor at high speed with differential lock engaged.
- Do not attempt to turn with the differential lock engaged.
- Be sure to release the differential lock before making a turn in field conditions.

If one of the rear wheels should slip, step on the differential lock pedal. Both wheels will turn together, then reduce slippage.

Differential lock is maintained only while the pedal is depressed.

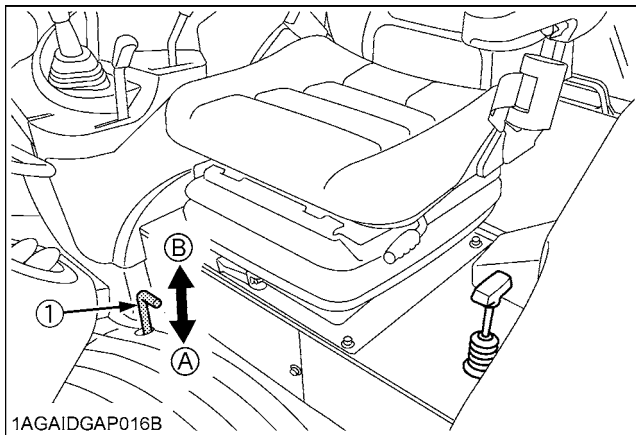

(1) Differential lock pedal (A) Press to "ENGAGE"
(B) Release to "DISENGAGE"

IMPORTANT :

- When using the differential lock, always slow the engine down.
- To prevent damage to power train, do not engage differential lock when one wheel is spinning and the other is completely stopped.
- If the differential lock cannot be released, step lightly on the brake pedals alternately.

■ Operating the Tractor on a Road



CAUTION

To avoid personal injury:

- To help assure straight line stops when driving at transport speeds, lock the brake pedals together. Uneven braking at road speeds could cause the tractor to roll-over.
- When traveling on road with 3-point hitch mounted implement attached, be sure to have sufficient front weight on the tractor to maintain steering ability.

Be sure SMV emblem and warning lamps are clean and visible. If towed or rear-mounted equipment obstructs these safety devices, install SMV emblem and warning lamps on equipment.

Consult your local KUBOTA Dealer for further details.

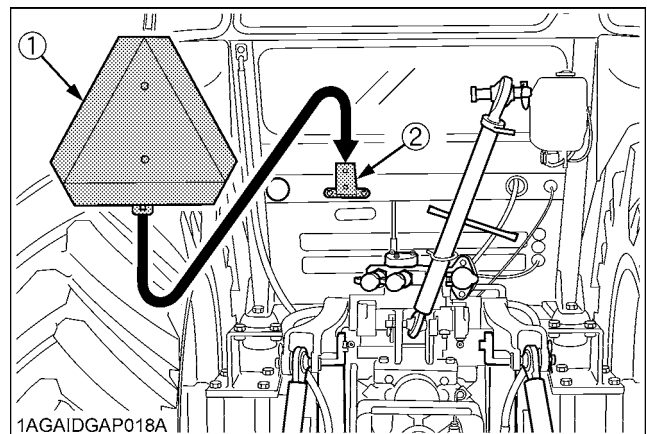

(1) SMV emblem
(2) Bracket

Operating on Slopes and Rough Terrain

CAUTION

To avoid personal injury:

- Always back up when going up a steep slope. Driving forward could cause the tractor to tip over backward. Stay off hills and slopes too steep for safe operation.
- Avoid changing gears when climbing or descending a slope.
- If operating on a slope, never disengage the clutch or shift levers to neutral. Doing so could cause loss of control.
- Do not drive the tractor close to the edges of ditches or banks which may collapse under the weight of the tractor. Especially when the ground is loose or wet.

1. Be sure wheel tread is adjusted to provide maximum stability.
(See "WHEEL ADJUSTMENT" in "TIRES, WHEELS AND BALLAST" section.)
2. Slow down for slopes, rough ground, and sharp turns, especially when transporting heavy, rear mounted equipment.
3. Before descending a slope, shift to a gear low enough to control speed without using brakes.

Directions for Use of Power Steering

1. Power steering is activated only while the engine is running. Slow engine speeds make the steering a little heavier. While the engine is stopped, the tractor functions in the same manner as tractors without power steering.
2. When the steering wheel is turned all the way to the stop, the relief valve is activated. Do not hold the steering wheel in this position for a long period of time.
3. Avoid turning the steering wheel while the tractor is stopped, or tires may wear out sooner.
4. The power steering mechanism makes the steering easier. Be careful when driving on a road at high speeds.

Trailer Electrical Outlet

A trailer electrical outlet is supplied for use with trailer or implement.

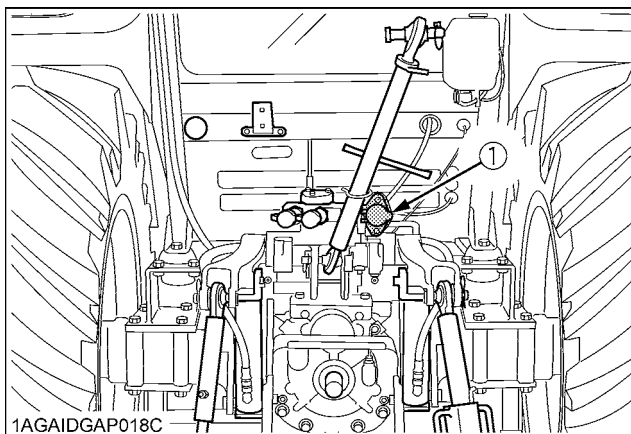

(1) Trailer electrical outlet

Function of each terminals in trailer electrical outlet

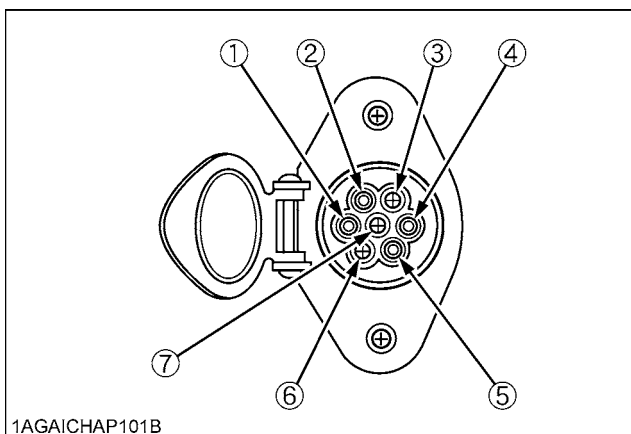

Terminal	Function
(1)	Ground
(2)	Tail light Sidemarker light Parking light
(3)	Turn signal light (LH)
(4)	Brake stop light
(5)	Turn signal light (RH)
(6)	Registration plate light
(7)	---

PTO

PTO OPERATION



CAUTION

To avoid personal injury:

- Disengage PTO, stop engine, and allow all rotating components to come to a complete stop before connecting, disconnecting, adjusting, or cleaning any PTO driven equipment.

■ PTO Clutch Control Lever

[Without Dual Speed model]

1. The tractor has a 540 rpm speed position and 6-spline shaft.
2. The PTO clutch control lever engages or disengages the PTO clutch which gives the PTO independent control.

Shift the lever to "ON" to engage the PTO clutch. Shift the lever to "OFF" to disengage the PTO clutch.

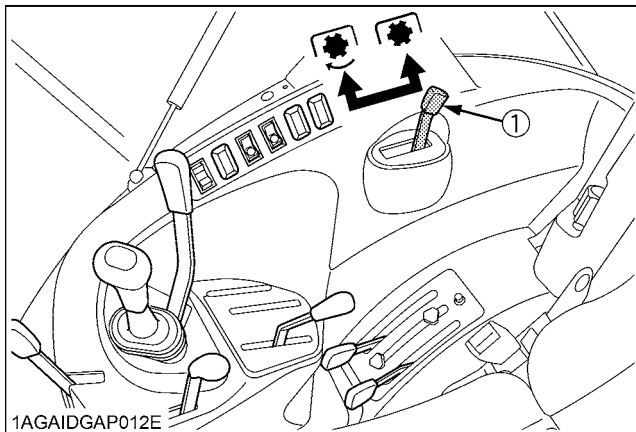

1AGAIDGAP012E

(1) PTO clutch control lever "ON" "OFF"

NOTE :

- Tractor engine will not start if PTO clutch control lever is in the engaged "ON" position.
- If the PTO system is engaged and you stand up from the seat, the warning buzzer will whistle for about 10 seconds after standing up. This is because the tractor is equipped with "Operator Presence Control System".

◆ PTO Clutch Indicator

The PTO clutch indicator turns on while PTO clutch control lever is in "ON" (Engage) position.

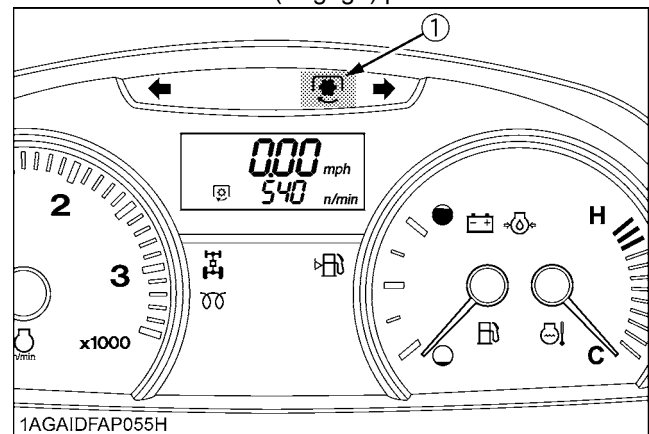

1AGAIDFAP055H

(1) PTO clutch indicator

IMPORTANT :

- To avoid shock loads to the PTO, reduce engine speed when engaging the PTO, then open the throttle to the recommended speed.
- To avoid damage of PTO clutch and implement, shift the PTO clutch control lever slowly, when engaging the PTO clutch. Do not keep the PTO clutch control lever half way.

Proper warm up is strongly recommended in cold weather.

Do not continuously shift the PTO clutch control lever.

■ PTO Clutch Control Switch

[With Dual Speed model]

The PTO clutch control switch engages or disengages the PTO clutch which gives the PTO independent control. Turn the switch to "ON" to engage the PTO clutch. Turn the switch to "OFF" to disengage the PTO clutch.

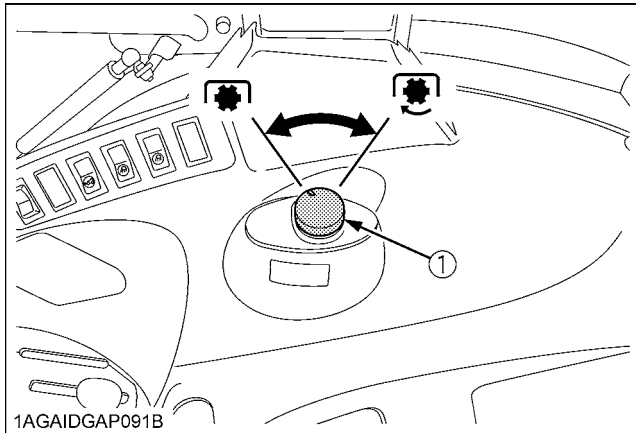

(1) PTO clutch control switch ⚙️ "ON" ⚙️/ "OFF"

◆ PTO Clutch Control Switch

To turn ON

While pushing the switch, turn clockwise to the "ON" position and release your hand. (In the ON position, switch slightly rises itself.)

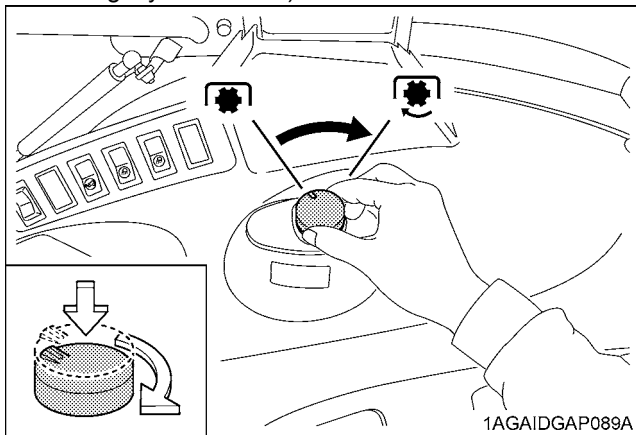

To Turn OFF

Tap on top of the switch, and the switch will return to the OFF position.

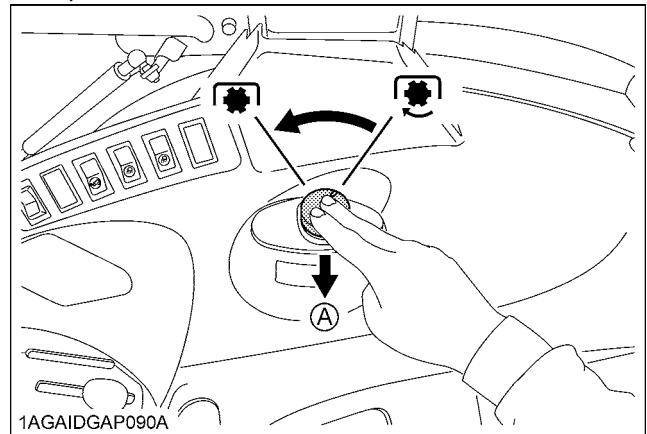

(A) "PUSH"

IMPORTANT :

- To avoid shock loads to the PTO, reduce engine speed when engaging the PTO, then open the throttle to the recommended speed.

NOTE :

- Tractor engine will not start if PTO clutch control switch is in the engaged "ON" position.
- If the PTO system is engaged and you stand up from the seat, the warning buzzer will whistle for about 10 seconds after standing up. This is because the tractor is equipped with "Operator Presence Control System".

◆ PTO Clutch Indicator

The PTO clutch indicator turns on while PTO clutch control switch is in "ON" (Engage) position.

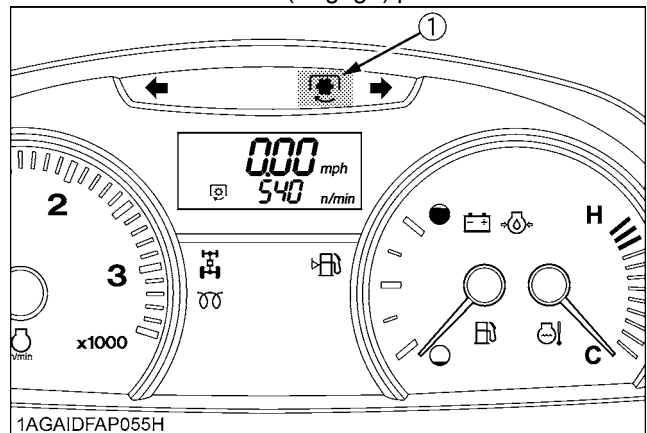

(1) PTO clutch indicator

■ 1000 rpm PTO Shaft

[if equipped]



WARNING

To avoid personal injury:

- Be sure to observe the PTO shaft speed prescribed for the individual implements. It is extremely dangerous to run an implement at high speed that is meant to be operated at low speed. Use only when this higher rpm is specifically recommended by the implement manufacturer.

By interchanging the PTO shafts, two different PTO shaft speeds can be obtained.

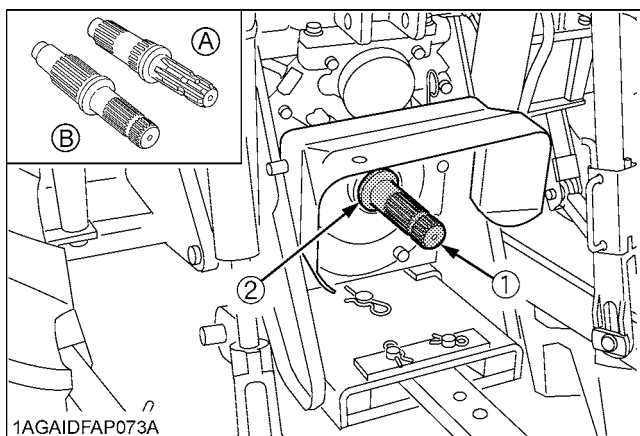

- (1) PTO shaft (A) 540 rpm PTO shaft
 (2) Snap ring (B) 1000 rpm PTO shaft

◆ PTO shaft interchanging procedure

1. The 6-spline 540 rpm PTO shaft is standard equipment.
2. Place an oil pan under the PTO shaft to catch oil spillage. Remove the snap ring, and then the PTO shaft.
3. Install the 21-spline PTO shaft (1000 rpm). To ensure that it is tight, push it in by turning.
4. Reinsert the snap ring.
5. Set the distance from drawbar pin hole to the rear end of PTO shaft according to the following instructions.

	PTO Shaft Type	Distance
540 rpm	6 - spline	355 mm (14 in.)
1000 rpm	21 - spline	406 mm (16 in.)

Engine speed rpm	PTO speed rpm
2035	540
2389	1000

IMPORTANT :

- For maximum PTO shaft speeds of various implements, see the implement Operator's Manual.

■ LCD Monitor Message

1. The PTO rpm can be checked in the LCD monitor. (See "PTO RPM / TRAVEL SPEED MONITOR" in "OPERATING THE TRACTOR" section.)
2. When the PTO system gets engaged (ON), the indicator lights up.

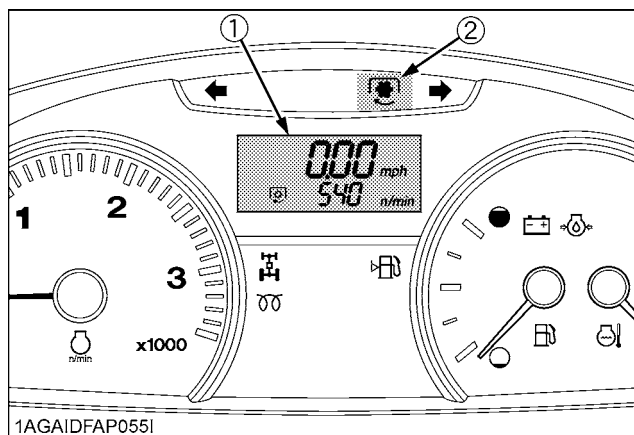

- (1) LCD monitor
 (2) PTO clutch indicator

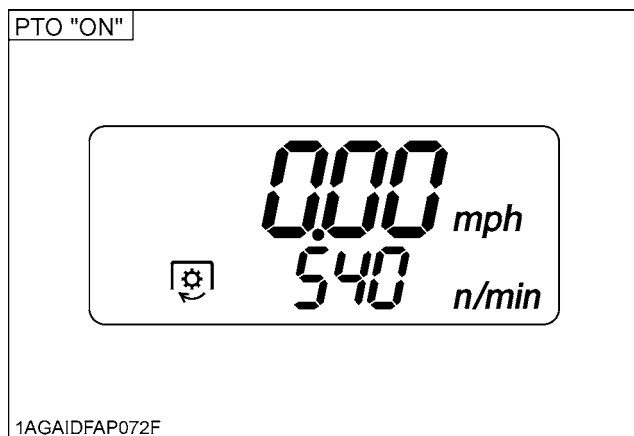

NOTE :

- When the PTO speed is changed from 540 rpm to 1000 rpm, it is necessary to switch the PTO speed display mode. Otherwise the PTO speed will not get correctly displayed in the LCD monitor. Such mode switching is also needed when returning to the 540 rpm PTO speed. (See "PTO RPM / TRAVEL SPEED MONITOR" in "OPERATING THE TRACTOR" section.)

■ PTO Shaft Cover and Shaft Cap

Keep the PTO shaft cover in place at all times. Replace the PTO shaft cap when the PTO is not in use. Before connecting or disconnecting a drive shaft to PTO shaft, be sure engine is "OFF". Raise up the PTO shaft cover. Afterward be sure to return the PTO shaft cover to the "NORMAL POSITION".

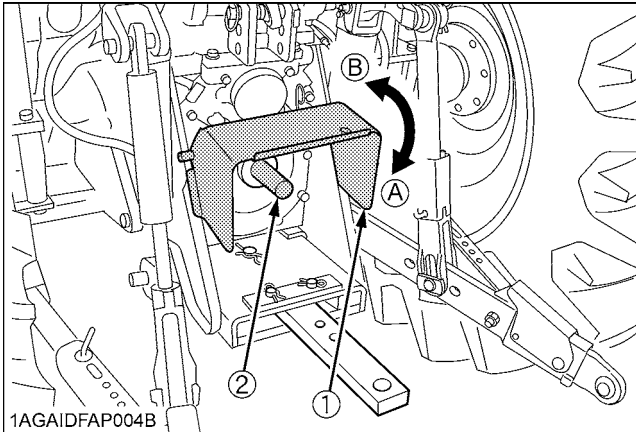

(1) PTO shaft cover
(2) PTO shaft cap

(A) "NORMAL POSITION"
(B) "RAISED POSITION"

THREE-POINT HITCH & DRAWBAR

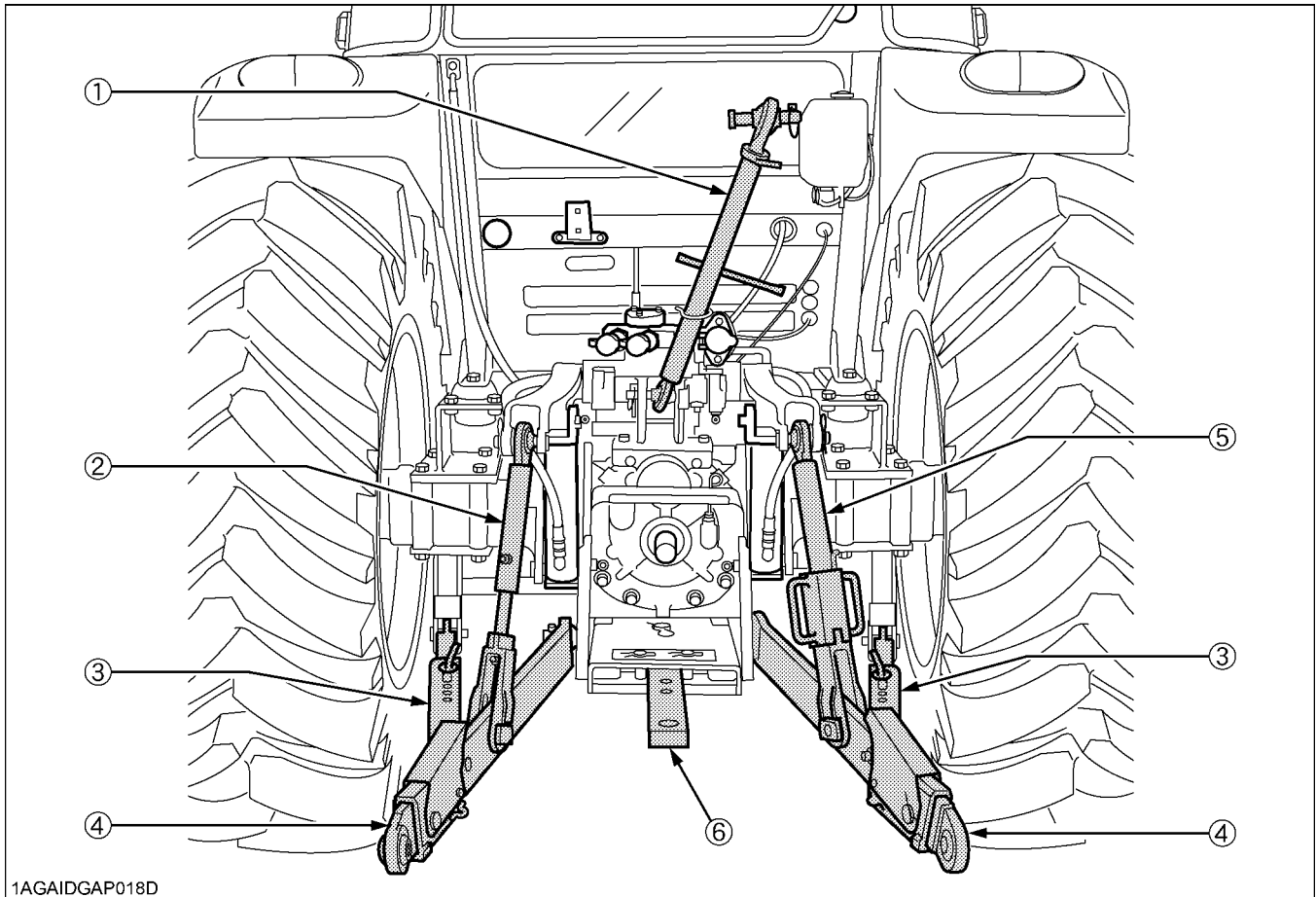

1AGAIDGAP018D

- (1) Top link
- (2) Lifting rod (Left)
- (3) Telescopic stabilizers
- (4) Lower link
- (5) Lifting rod (Right)
- (6) Drawbar

3-POINT HITCH

1. Make preparations for attaching implement.

■ Selecting the holes of Lower Links

There are three holes in the lower links. For most operations the lifting rods should be attached to the (B) hole.

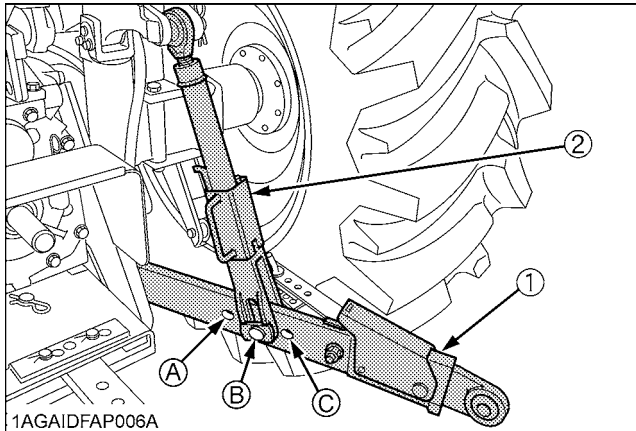

(1) Lower link
(2) Lifting rod

holes: (A), (B), (C)

NOTE :

- The lifting rods may be attached to (A) hole for higher lifting height. (with reduced lifting force)
- The lifting rods may be attached to (C) for greater lifting force.

■ Adjusting Lateral Float

To allow the implement to follow ground contour, attach the rectangular washers and pin heads in vertical position. To hold the implement, reset the rectangular washers and pin heads in horizontal position.

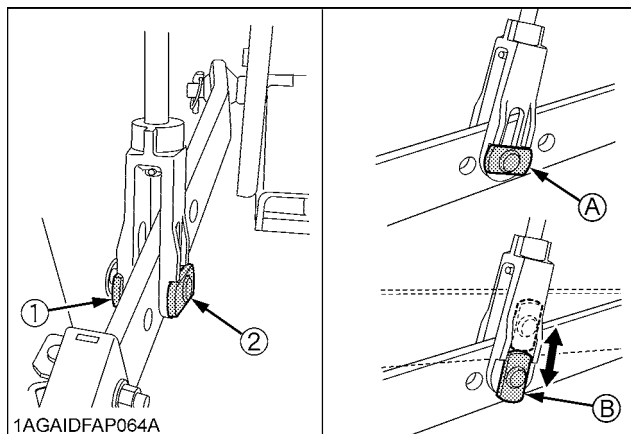

(1) Rectangular washer
(2) Pin head

(A) Horizontal position
(B) Vertical position

◆ Floating mechanism

When the floating mechanism is used, the implement is able to follow the tractor freely in response to the soil and ground conditions. This is suited for operation with implements wider than the tractor.

■ Selecting the Top Link Mounting Holes

Select the proper set of holes by referring to the "Hydraulic Control Unit Use Reference Chart" in Hydraulic Unit section.

If the hydraulic unit is set for draft control, draft response is more sensitive when an implement is connected to the lower set of top link mounting holes. If draft control is not required, it is recommended to use the top set (1).

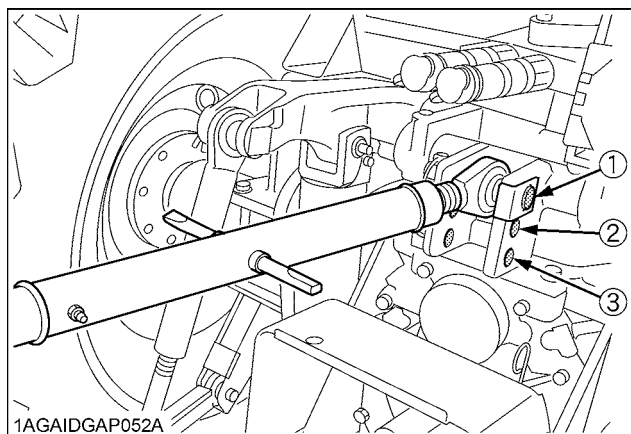

■ Drawbar

Remove the drawbar if a close mounted implement is attached.

2. Attaching and detaching implements

CAUTION

To avoid personal injury:

- Be sure to stop the engine.
- Do not stand between tractor and implement unless parking brake is applied.
- Before attaching or detaching implement, locate the tractor and implement on a firm level surface.
- Whenever an implement or other attachment is connected to the tractor 3-point hitch, check full range of operation for interference, binding or PTO separation.
- Do not exceed maximum allowable length of either lifting rod, or the lifting rod will come apart and the 3-point equipment may fall.

■ Lifting Rod (Left)

By turning the rod itself, the lifting rod varies its length. When extending the rod, do not exceed the groove on the rod thread.

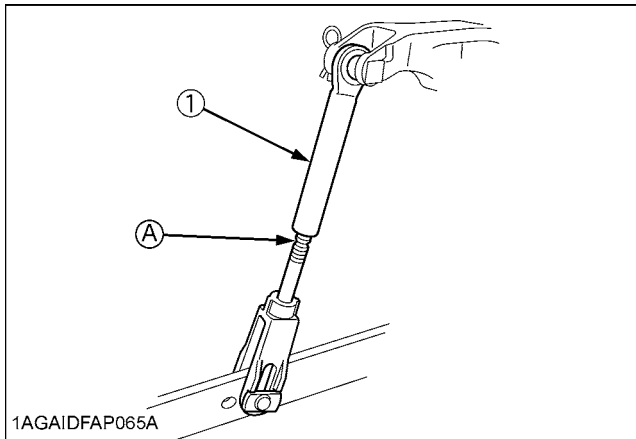

(1) Lifting rod

(A) "GROOVE"

■ Lifting Rod (Right)

CAUTION

To avoid personal injury:

- Do not extend lifting rod beyond the groove on the thread rod.

1. To adjust the length of the lifting rod, lift the adjusting handle and turn to desired length.
2. After adjusting, lower the lifting rod adjusting handle to the lock position.
3. When extending the rod using adjusting handle, do not exceed the groove on the rod thread.

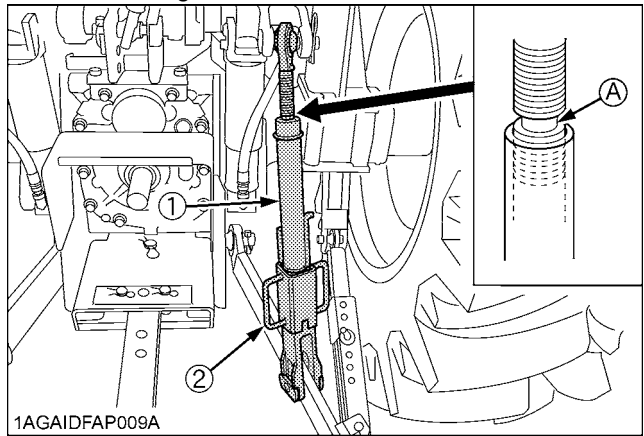

(1) Lifting rod

(2) Adjusting handle

(A) "GROOVE"

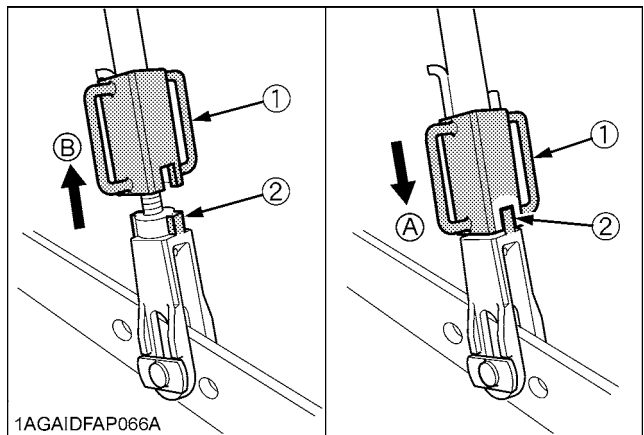

(1) Adjusting handle

(2) Lock pin

(A) "LOCK POSITION"

(B) "UNLOCK POSITION"

Top Link

CAUTION

To avoid personal injury:

- When extending the top link, do not exceed the groove on the top link thread, or the top link will come apart and the 3-point equipment may fall.

1. Adjust the angle of the implement to the desired position by shortening or lengthening the top link.
2. The proper length of the top link varies according to the type of implement being used.

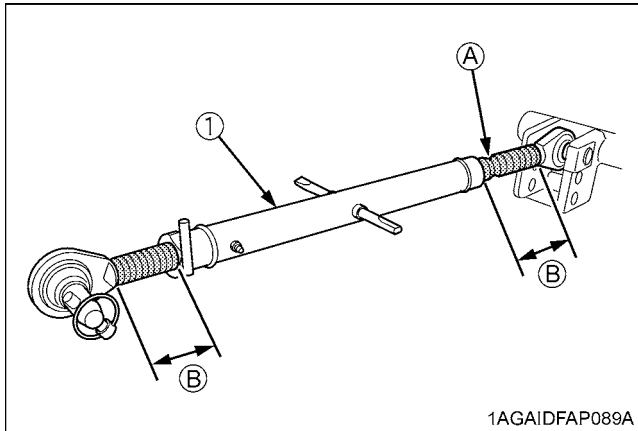

(1) Top link (A) "GROOVE" (B) "Length of the screw"

NOTE :

- The length of the screw at both ends of the top link must be the same always.

Telescopic Stabilizers

Adjust the telescopic stabilizers to control horizontal sway of the implement. Select the proper set of holes by referring to the "Hydraulic Control Unit Use Reference Chart" in "REMOTE HYDRAULIC CONTROL SYSTEM" in "HYDRAULIC UNIT" section.

After aligning satisfactorily, insert the set-pin through any one of the five holes on the outer tube that align with one of the holes on the inner bar, both stabilizers will be locked.

If the set-pin is inserted through the slot to engage one of the holes on the inner bar, a limited degree of sway will be permitted.

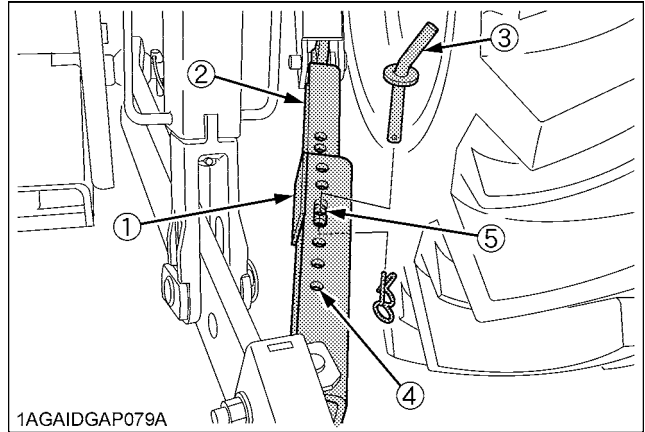

(1) Outer tube (2) Inner bar (3) Set-pin (4) Hole (5) Slot

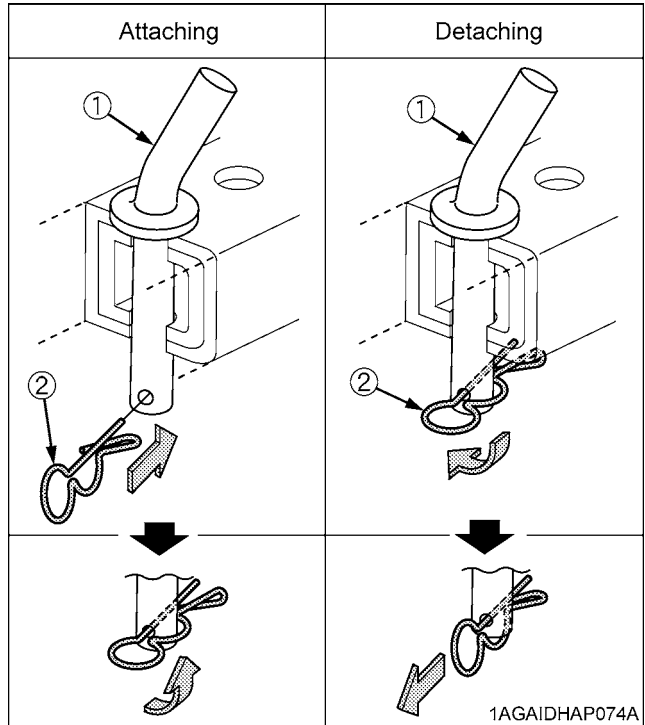

(1) Set-pin (2) Hairpin cotter

■ Telescopic Lower Links

To attach an implement, follow the instructions below:

1. Push the levers, pull out the lower link ends, and attach to the implement.
2. Back up the tractor slightly to make sure the lower links are pushed in securely.

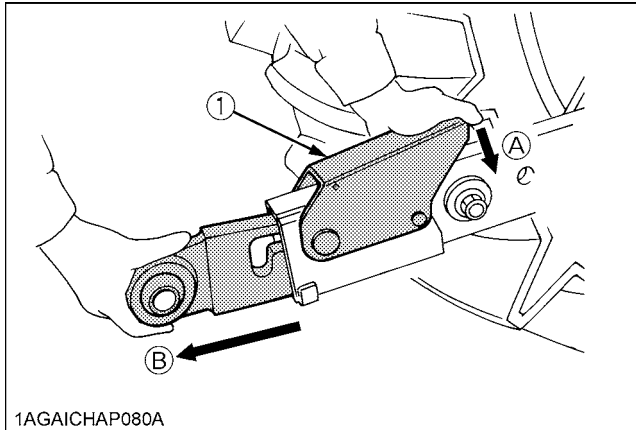

(1) Lever

(A) "PUSH"

(B) "PULL OUT"

DRAWBAR



WARNING

To avoid personal injury:

- Never pull from the top link, the rear axle or any point above the drawbar. Doing so could cause the tractor to tip over rearward causing personal injury or death.

■ Adjusting Drawbar Length

When towing an implement, it is recommended that the (A) hole in drawbar be utilized.

The drawbar load is specified in the "IMPLEMENT LIMITATIONS" section.

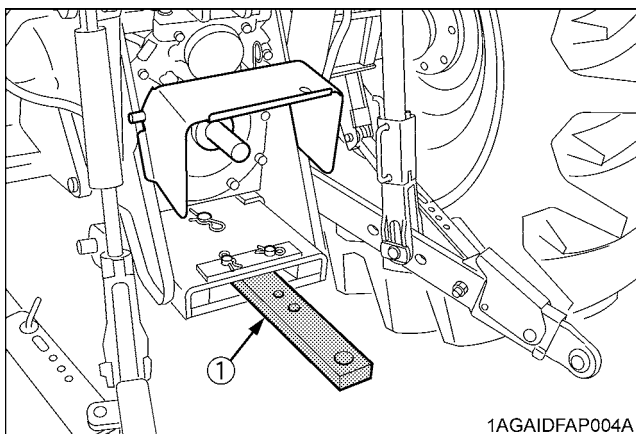

1AGAIDFAP004A

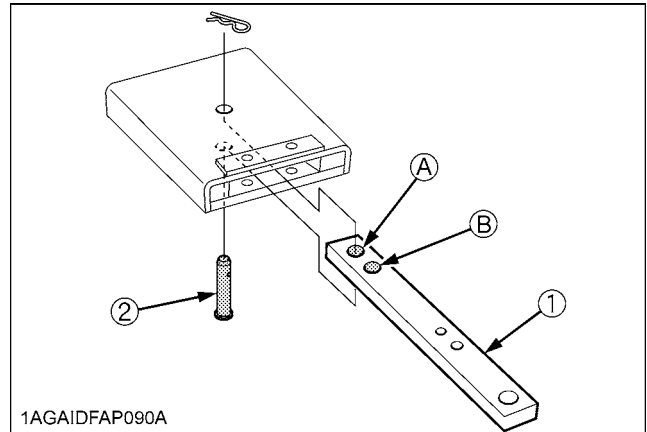

(1) Drawbar

Holes: (A), (B)

(2) Drawbar pin

■ Swing Drawbar

The drawbar can be used in three different ways as illustrated below. Assemble it correctly with drawbar pins.

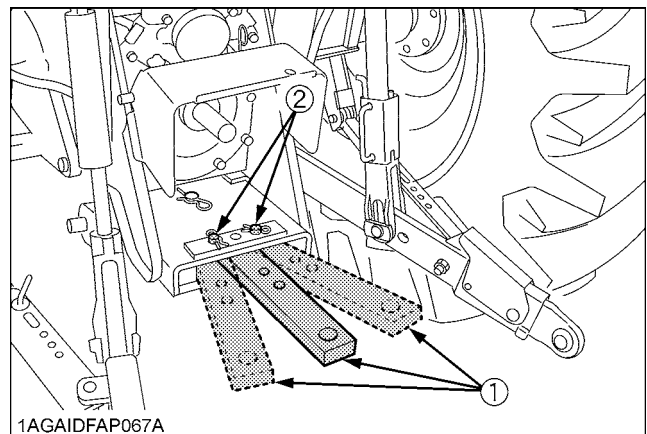

(1) Drawbar

(2) Drawbar pin

HYDRAULIC UNIT

The standard tractor has 5 hydraulic control systems as shown below. Therefore, use the most appropriate system for the implement you are using.

◆ 3-Point Hitch Control System

1. Position Control
2. Draft Control
3. Mixed Control
4. Float Control

◆ Remote Hydraulic Control System

5. Combined Flow Control

IMPORTANT :

- Do not operate until the engine is warmed up. If operation is attempted when the engine is still cold, the hydraulic system may be damaged.
- If noises are heard when implement is lifting after the hydraulic control lever has been activated, the hydraulic mechanism is not adjusted properly. Unless corrected, the unit will be damaged. Contact your KUBOTA Dealer for adjustment.

3-POINT HITCH CONTROL SYSTEM

■ Position Control

This will control the working depth of 3-point hitch mounted implement regardless of the amount of pull required.

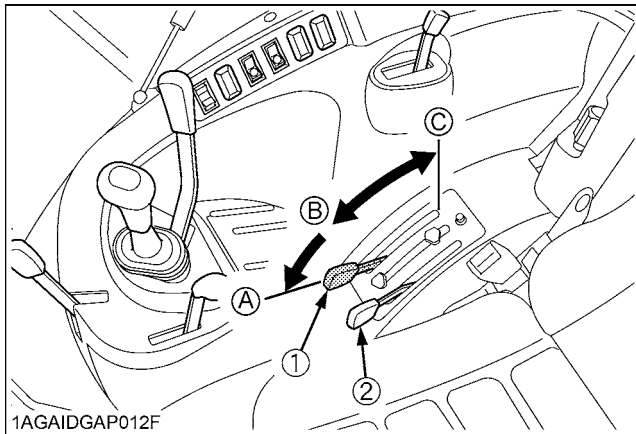

- | | |
|----------------------------|-------------|
| (1) Position control lever | (A) "FLOAT" |
| (2) Draft control lever | (B) "DOWN" |
| | (C) "UP" |

■ Draft Control

This will control the pull of the 3-point implement. As the load on the 3-point hitch changes due to various soil conditions, the draft control system automatically responds to these changes by either raising or lowering the implement slightly to maintain a constant pull.

Place the position control lever in the lowest position and set the implement pull with the draft control lever.

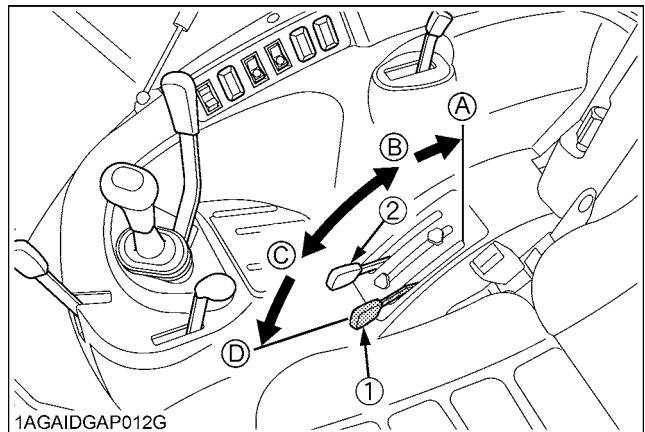

- | | |
|----------------------------|-------------------|
| (1) Draft control lever | (A) "UP" |
| (2) Position control lever | (B) "SENSITIVE" |
| | (C) "INSENSITIVE" |
| | (D) "FLOAT" |

■ Mixed Control

In draft control, when draft decreases, the implement automatically lowers to increase draft. However, the implement sometimes lowers too much. To limit the degree, the implement can be lowered, set the position control lever at the lowest working depth desired for the implement. Lower the draft control lever to the point where the implement is at the desired depth.

This stops the implement from going too deep and causing loss of traction and ground speed.

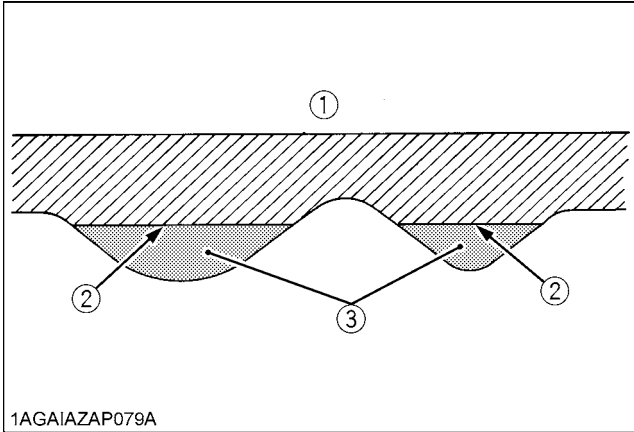

1AGAIAZAP079A

- (1) Ground surface
- (2) Implement penetration limit
- (3) Light soil

■ Float Control

Place both the draft control lever and the position control lever in the float position to make the lower links move freely along with the ground conditions.

■ 3-point Hitch Lowering Speed



CAUTION

To avoid personal injury:

- Fast lowering speed may cause damage or injury. Lowering speed of implement should be adjusted to two or more seconds.

The lowering speed of the 3-point hitch can be controlled by adjusting the 3-point hitch lowering speed knob.

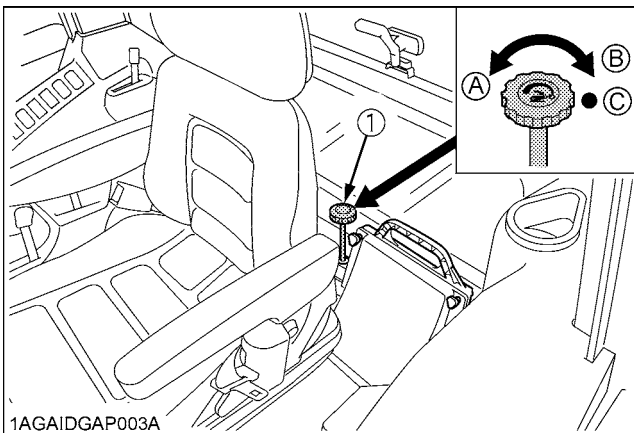

1AGAIIDGAP003A

- (1) 3-point hitch lowering speed knob
- (A) "FAST"
- (B) "SLOW"
- (C) "LOCK"

REMOTE HYDRAULIC CONTROL SYSTEM

The hydraulic auxiliary control valves can be installed up to triple segments.

It is not possible to use triple segments with flow control valve.

■ Remote Control Valve

There are two types of remote valves available for these models.

- Double acting valve with detents and self cancelling:
This valve may be placed in the detent mode. The lever will stay in this position until the pressure reaches a predetermined level or a cylinder reaches the end of its stroke. Then it will automatically return to neutral
- Double acting valve with float position:
This valve may be placed in the float mode with the control lever all the way forward. The cylinder is free to extend or retract, letting an implement such as a loader bucket follow the ground.

Remote Control Valve Lever

The remote control valve lever directs pressurized oil flow to the implement hydraulic system.

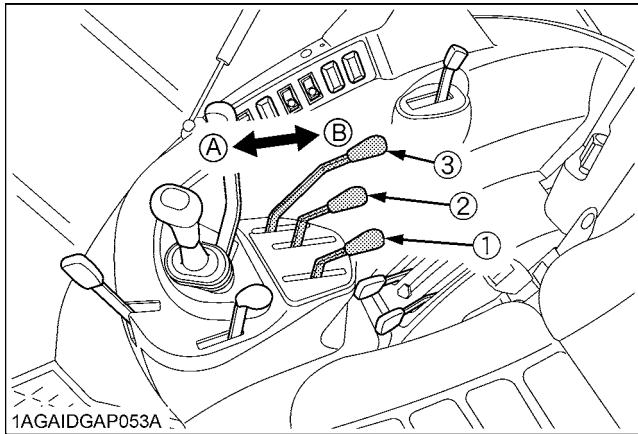

(1) Remote control valve lever 1 (A) "PUSH"
 (2) Remote control valve lever 2 (B) "PULL"
 (3) Remote control valve lever 3

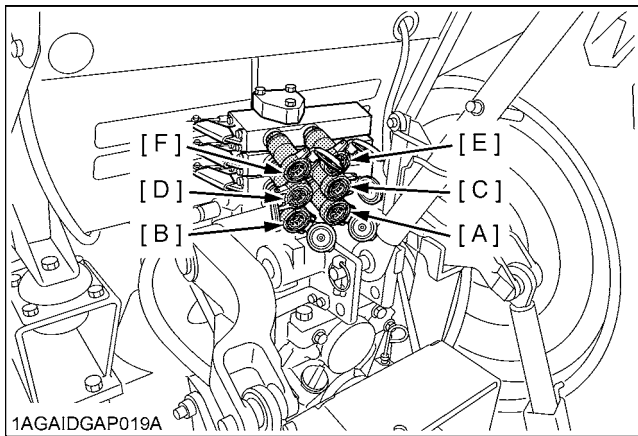

Pressure →
 Returning ←

Lever (1)		Push	Pull
Port	[A]	Out →	In ←
	[B]	In ←	Out →

Lever (2)		Push	Pull
Port	[C]	Out →	In ←
	[D]	In ←	Out →

Lever (3)		Push	Pull
Port	[E]	Out →	In ←
	[F]	In ←	Out →

IMPORTANT :

- Do not hold the lever in the "pull" or "push" position once the remote cylinder has reached the end of the stroke, as this will cause oil to flow through the relief valve. Forcing oil through the relief valve for extended periods will overheat the oil.
- When using the tractor hydraulic system to power front loader, do not operate boom and bucket cylinders simultaneously.

NOTE :

- Connect the pressure of load side of implement cylinders to ports [B], [D] or [F] which have built in load check valve to prevent leak down.
- To use the single-acting cylinder with the float valve, connect this cylinder to the [B], [D] or [F] port. To extend a single-acting cylinder, pull the remote control valve lever rearward. To retract a cylinder, push it fully forward to the "FLOAT" position. Do not hold it in the down position, the transmission fluid may be overheat.

Remote Control Valve Coupler Connecting and Disconnecting



CAUTION

To avoid personal injury:

- Stop the engine and relieve pressure before connecting or disconnecting lines.
- Do not use your hand to check for leaks.

Connecting

1. Clean both couplers.
2. Remove dust plugs.
3. Insert the implement coupler to the tractor hydraulic coupler.
4. Pull the implement coupler slightly to make sure couplers are firmly connected.

Disconnecting

1. Lower the implement first to the ground to release hydraulic pressure in the hoses.
2. Clean the couplers.
3. Relieve pressure by moving hydraulic control levers with engine shut off. Pull the hose straight from the hydraulic coupler to release it.
4. Clean oil and dust from the coupler, then replace the dust plugs.

NOTE :

- Your local KUBOTA Dealer can supply parts to adapt couplers to hydraulic hoses.

■ Flow Control Valve (option)

The optional flow control valve may be added for the following purposes.

1. To operate within limits, the remote control valve (2) above the flow control valve (3) and the 3-point hitch at the same time without one affecting the other.
2. To operate within limits, the remote control valve (2) above the flow control valve (3) and the other remote control valve (1) at the same time without one affecting the other. Activating the remote control valve (1) will interrupt the operation of the 3-point hitch.
3. To maintain within limits, the constant speed of an attachment (hydraulic motor RPM, for example) when connected to the remote control valve (2) above the flow control valve (3).

NOTE :

- At slower engine speeds the total hydraulic flow rate may be inadequate for simultaneous operation of the remote control valve (2) and the 3-point hitch or the remote control valve (1), or operation of an attachment connected to the remote control valves (1)(2). Under these conditions, the engine speed must be increased to provide additional hydraulic flow.

■ Adjusting the flow rate



CAUTION

To avoid the possibility of personal injury be aware of the following when making adjustments:

- The 3-point hitch operation is influenced by the combination of the adjustment of the flow control valve and the engine speed.
- The 3-point hitch may raise slowly or not at all at low engine RPM.
- The 3-point hitch may raise suddenly if engine RPM is increased, or, flow control adjustment is changed.

Refer to the illustration below.

1. The flow rate for the remote control valve (2), located on above the flow control valve (3), can be adjusted.
2. Turn the flow control knob (4) counterclockwise (A), and the flow rate for the remote control valve (2) increases. A clockwise turn (B) of the knob causes the flow to decrease. If the knob is turned all the way (C), there will be no flow.
3. To adjust the flow rate, set the engine speed to the operating RPM, turn the flow control knob once all the way clockwise (C), and then turn it gradually counterclockwise until a required flow rate is reached.

NOTE :

- Full adjustment of the valve will occur in approximately 1 1/2 revolutions of the flow control knob. Turning the flow control knob beyond this point will have no effect on the flow rate.

IMPORTANT :

- When there is no need to adjust the flow rate, turn the flow control knob all the way counterclockwise and keep it in this position.

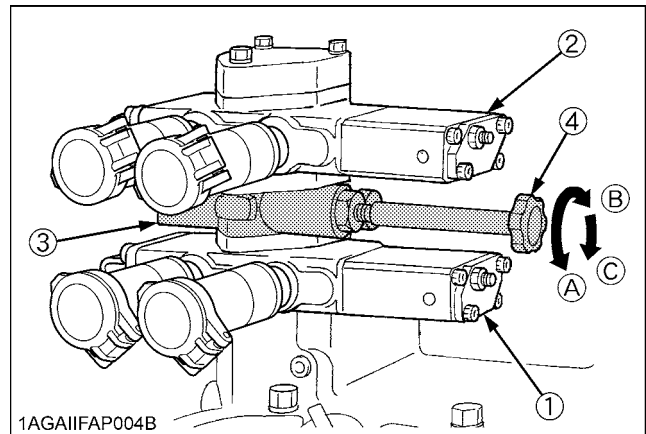

- | | |
|------------------------------|----------------|
| (1) Remote control valve (1) | (A) "INCREASE" |
| (2) Remote control valve (2) | (B) "DECREASE" |
| (3) Flow control valve | (C) "STOP" |
| (4) Flow control knob | |

■ Positions and advantages of the flow control valve

Refer to illustration below.

◆ Position 1

1. The attachment control speed (hydraulic motor RPM, for example) of the remote control valve (1) can be maintained at a constant level within limits.
2. The remote control valve (1) and the 3-point hitch can be operated at the same time. The 3-point lift speed will be influenced by the level of flow required at remote control valve (1).

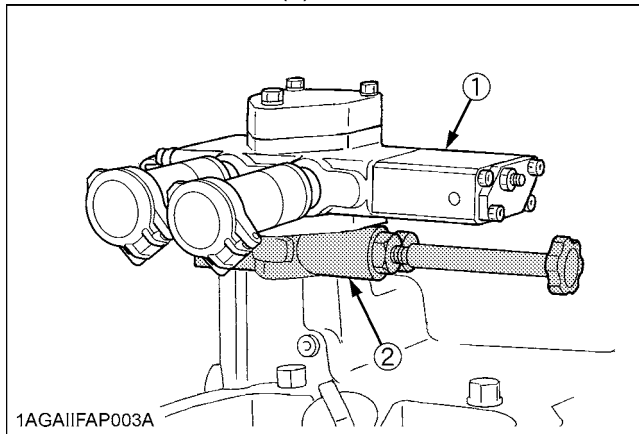

(1) Remote control valve (1)
(2) Flow control valve

◆ Position 2

1. The attachment control speed (hydraulic motor RPM, for example) of the remote control valve (2) can be maintained at a constant level.
2. The remote control valve (2) and the 3-point hitch can be operated at the same time with the speed of the 3-point being influenced by the adjustment range of the flow control valve.
3. Remote control valves (1) and (2) can be operated at the same time with operation of the 3-point hitch being interrupted by activation of valve (1).
4. The operation of valve (1) is influenced by the flow adjustment to valve (2).
5. The 3-point hitch lift speed and the flow available for valve (1) are influenced by the flow adjustment of valve (2).

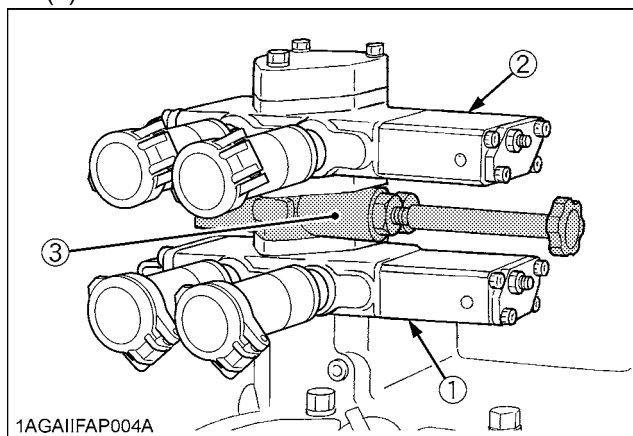

(1) Remote control valve (1)
(2) Remote control valve (2)
(3) Flow control valve

Hydraulic Control Unit Use Reference Chart

In order to handle the hydraulics properly, the operator must be familiar with the following.

Though this information may not be applicable to all types of implements and soil conditions, it is useful for general conditions.

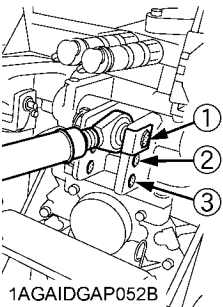
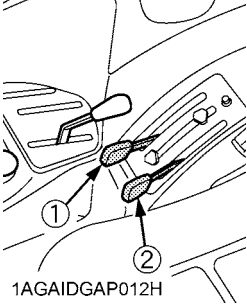
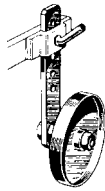
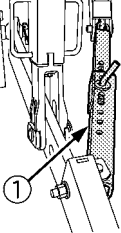
Implement	 1AGAI AZAP122A Soil condition	 1AGAI DGAP052B Top link mounting holes	 1AGAI DGAP012H (1) Position control lever (2) Draft control lever	 1AGAI AZAP070A Gauge wheel	 1AGAI DFAP069A (1) Telescopic stabilizers	Remarks
Moldboard plow	Light soil Medium soil Heavy soil	3 2 or 3 2	Draft and Mixed control	YES/NO	Loose	Insert the set-pin through the slot on the outer tube that align with one of the holes on the inner bar.
Disc plow	---	2 or 3	(Place the draft control lever to the suitable position and set the implement pull with the position control lever.)	YES/NO	Loose	For implements with gauge wheels, lower the position control lever all way.
Harrower (spike, springtooth, disc type)	---	2				
Sub-soiler.....	---	2				
Weeder, ridger.....	---	1	Position control (Hold the draft control lever at the front most position during operation.)	YES	Tighten	Telescopic stabilizer should be tight enough to prevent excessive implement movement when implement is in raised position. For implements with gauge wheels, lower the position control lever all way.
Earthmover, digger, scraper, manure fork, rear carrier.....				YES/NO		
Mower (mid- and rear-mount type) Hayrake, tedder.....				NO		

TIRES, WHEELS AND BALLAST

TIRES



WARNING

To avoid personal injury:

- Do not attempt to mount a tire on a rim. This should be done by a qualified person with the proper equipment.
- Always maintain the correct tire pressure. Do not inflate tires above the recommended pressure shown in the operator's manual.

IMPORTANT :

- Do not use tires other than those approved by KUBOTA.

NOTE :

- When optional different-diameter tires are fitted on the machine, the travel speed display mode must be changed. Otherwise the travel speed will not get correctly displayed. Such mode switching is also needed when the original tires are back on the machine.
(See "PTO RPM / TRAVEL SPEED MONITOR" in "OPERATING THE TRACTOR" section.)

■ Inflation Pressure

Though the tire pressure is factory-set to the prescribed level, it naturally drops slowly in the course of time. Thus, check it everyday and inflate as necessary.

	Tire sizes	Inflation Pressure
Front	7.50-18, 6PR	280 kPa (2.8 kgf/cm ² , 40 psi.)
	9.5L-15, 6PR	220 kPa (2.2 kgf/cm ² , 32 psi.)
	9.5-22, 6PR	200 kPa (2.0 kgf/cm ² , 29 psi.)
	10.00-16, 6PR	200 kPa (2.0 kgf/cm ² , 29 psi.)
	11.2-24, 6PR	160 kPa (1.6 kgf/cm ² , 23 psi.)
	12.4-24, 6PR	140 kPa (1.4 kgf/cm ² , 20 psi.)
Rear	16.9-34, 6PR	120 kPa (1.2 kgf/cm ² , 18 psi.)
	18.4-28, 6PR	110 kPa (1.1 kgf/cm ² , 16 psi.)
	18.4-30, 6PR	110 kPa (1.1 kgf/cm ² , 16 psi.)

NOTE :

- Maintain the maximum pressure in front tires, if using a front loader or when equipped with a full load of front weights.

■ Dual Tires

Dual tires are not approved.

WHEEL ADJUSTMENT



CAUTION

To avoid personal injury:

- When working on slopes or when working with trailer, set the wheel tread as wide as practical for maximum stability.
- Support tractor securely on stands before removing a wheel.
- Do not work under any hydraulically supported devices. They can settle, suddenly leak down, or be accidentally lowered. If necessary to work under tractor or any machine elements for servicing or adjustment, securely support them with stands or suitable blocking beforehand.
- Never operate tractor with a loose rim, wheel, or axle.

■ Front Wheels (with two wheel drive)

Front tread width can be adjusted as shown with the standard equipped tires.

To change the tread width

1. Remove the front axle mounting bolts and the tie-rod mounting bolts.
2. Move the front axles (right and left) to the desired position, and tighten the bolts.
3. Adjust the toe-in: [1 to 5 mm (0.04 to 0.2 in.)]
(See "Adjusting Toe-in" in "EVERY 200 HOURS" in "PERIODIC SERVICE" section.)

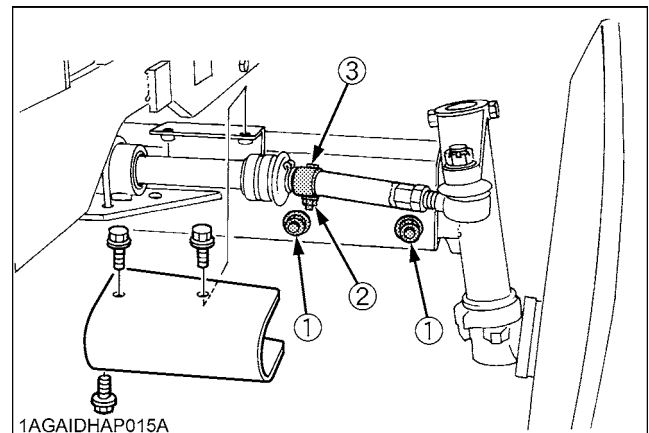

- (1) Front axle mounting bolt
124 to 147 N-m (12.6 to 15 kgf-m) [91.5 to 108.9 ft-lbs.]
- (2) Tie-rod mounting bolt
61 to 71 N-m (6.2 to 7.2 kgf-m) [44.8 to 52.1 ft-lbs.]
- (3) Tie rod clamp

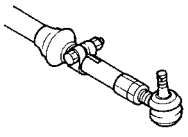
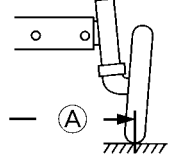
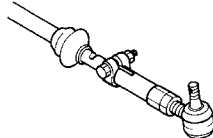
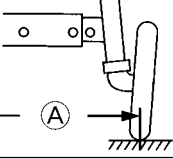
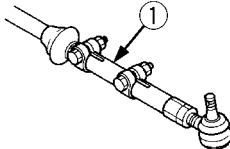
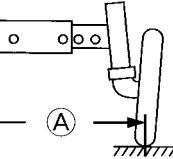
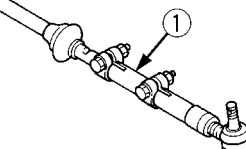
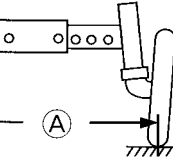
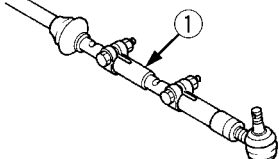
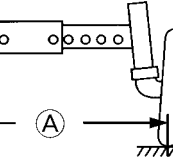
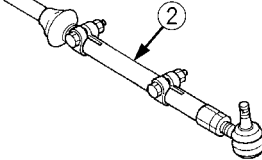
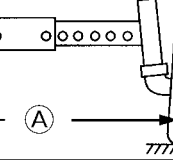
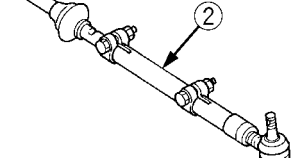
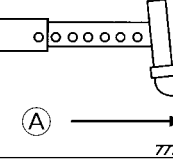
	
	1440 mm (56.7 in.)
	
	1540 mm (60.6 in.)
	
	1640 mm (64.6 in.)
	
	1740 mm (68.5 in.)
	
	1840 mm (72.4 in.)
	
	1940 mm (76.4 in.)
	
1AGAIDFAP078A	2040 mm (80.3 in.)

(1) Extension1 (short spacer)
(2) Extension2 (long spacer)

(A) "TREAD"

IMPORTANT :

- The front tread width for the front loader application on 2WD models should not be greater than 1540 mm (60.6 in.).

Front Wheels (with four wheel drive)

Front tread width can be adjusted as shown with the standard equipped tires.

To change the tread width

1. Remove the wheel rim and disk mounting bolts.
2. Change the position of the rim and disk (right and left) to the desired position, and tighten the bolts.
3. Adjust the toe-in [2 to 8mm (0.1 to 0.3 in.)]
See "Adjusting Toe-in" in "EVERY 200 HOURS" in "PERIODIC SERVICE" section.

IMPORTANT :

- Always attach wheels as shown in the drawing.
- If not attached as illustrated, transmission parts may be damaged.
- When re-fitting or adjusting a wheel, tighten the bolts to the following torques then recheck after driving the tractor 200m (200 yards) and thereafter according to service interval. (See "MAINTENANCE" section.)

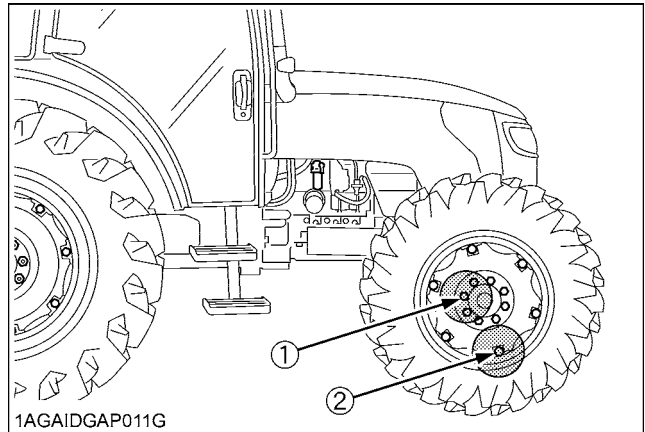

- (1) 260 to 304 N-m (26.5 to 31 kgf-m) (192 to 224 ft-lbs)
(2) 244 N-m (24.9 kgf-m) (180 ft-lbs)

NOTE :

- Wheels with beveled or tapered holes: Use the tapered side of lug nut.

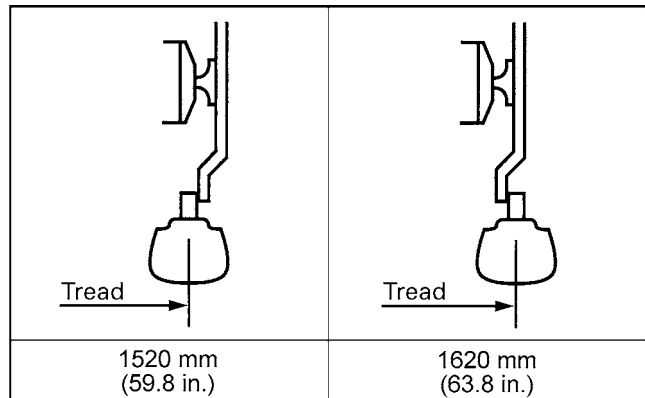

■ Rear Wheels

Rear tread width can be adjusted as shown with the standard equipped tires.

To change the tread width

1. Remove the wheel rim and / or disk mounting bolts.
2. Change the position of the rim and / or disk (right and left) to the desired position, and tighten the bolts.

IMPORTANT :

- Always attach wheels as shown in the drawing.
- If not attached as illustrated, transmission parts may be damaged.
- When re-fitting or adjusting a wheel, tighten the bolts to the following torques then recheck after driving the tractor 200m (200 yards) and thereafter according to service interval.
(See "MAINTENANCE" section.)

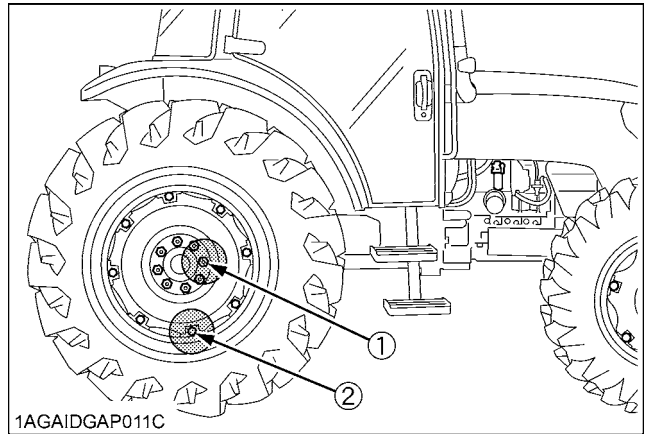

N-m (kgf-m) [ft-lbs]

(1)	(2)	
	Steel disk	Cast iron disk
343 to 401 (35.0 to 41.0) [254 to 297]	244 (24.9) [180]	260 to 304 (26.5 to 31.0) [192 to 224]

1AGAIDFAP080A						
M8540	18.4–28	1520 mm (59.8 in.)	1620 mm (63.8 in.)	1720 mm (67.7 in.)	1820 mm (71.7 in.)	1920 mm (75.6 in.)
M9540	18.4–30	1520 mm (59.8 in.)	1620 mm (63.8 in.)	1720 mm (67.7 in.)	1820 mm (71.7 in.)	1920 mm (75.6 in.)

BALLAST



CAUTION

To avoid personal injury:

- Additional ballast will be needed for transporting heavy implements. When the implement is raised, drive slowly over rough ground, regardless of how much ballast is used.
- Do not fill the front wheels with liquid to maintain steering control.

■ Front Ballast

Add weights if needed for stability (2WD, 4WD models) and improve traction (4WD model). Heavy pulling and heavy rear mounted implements tend to lift front wheels. Add enough ballast to maintain steering control and prevent tip over. Remove weight when no longer needed.

◆ Front End Weights (option)

The front end weights can be attached to the bumper. See your implement operator's manual for required number of weights or consult your local KUBOTA Dealer to use.

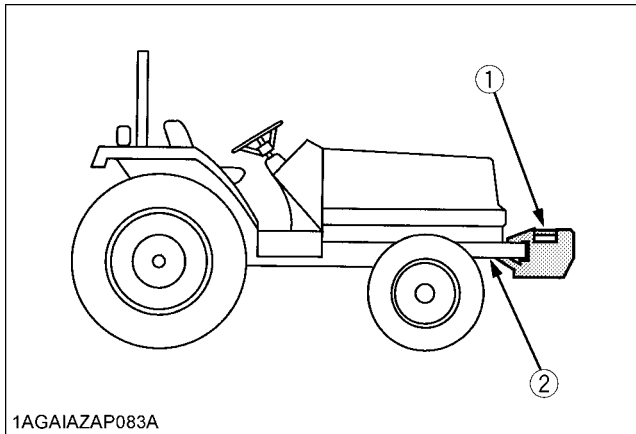

1AGAIAZAP083A

- (1) Front end weights
(2) Bumper

IMPORTANT :

- Do not overload tires.
- Add no more weight than indicated in chart.
- Do not attach the front bumper when the front loader is attached.

Maximum weight	47 kg x 10 pieces (1036 lbs.)
----------------	----------------------------------

■ Rear Ballast

Add weight to rear wheels if needed to improve traction or for stability. The amount of rear ballast should be matched to job and the ballast should be removed when it is not needed.

The weight should be added to the tractor in the form of liquid ballast, rear wheel weights, and/or cast iron disks.

◆ Cast Iron Disk (option)

The cast iron rear wheel disk may be utilized to provide additional rear weight.

Tire size	Cast Iron Disk
18.4-28 18.4-30	158 kg x 2 Pieces (700 lbs.)
16.9-34	270 kg x 2 Pieces (1200 lbs.)

◆ Rear Wheel Weights (option)

The rear wheel weights can be attached to the rear wheel. See your implement operator's manual for required number of weights or consult your local KUBOTA Dealer to use.

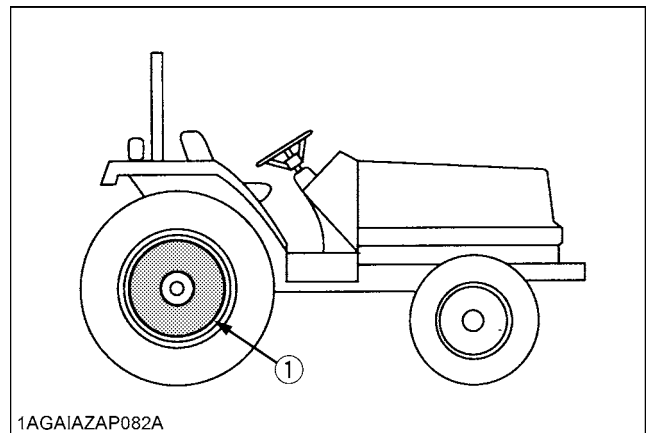

1AGAIAZAP082A

- (1) Rear wheel weights

IMPORTANT :

- Do not overload tires.
- Add no more weight than indicated in chart.

Rear wheel weight	73 kg x 2 pieces (320 lbs.)
-------------------	--------------------------------

◆ **Liquid Ballast in Rear Tires**

Water and calcium chloride solution provides safe economical ballast. Used properly, it will not damage tires, tubes or rims. The addition of calcium chloride is recommended to prevent the water from freezing. Use of this method of weighting the wheels has the full approval of the tire companies. See your tire dealer for this service.

Liquid weight per tire (75 Percent filled)

Tire sizes	16.9-34	18.4-28	18.4-30
Slush free at -10 °C (-14 °F) Solid at -30 °C (-22 °F) [Approx. 1 kg (2 lbs.) CaCl ₂ per 4 L (1 gal.) of water]	342 kg (755 lbs.)	357 kg (787 lbs.)	385 kg (848 lbs.)
Slush free at -24 °C (-11 °F) Solid at -47 °C (-53 °F) [Approx. 1.5 kg (3.5 lbs.) CaCl ₂ per 4 L (1 gal.) of water]	376 kg (829 lbs.)	387 kg (853 lbs.)	414 kg (912 lbs.)
Slush free at -47 °C (-53 °F) Solid at -52 °C (-62 °F) [Approx. 2.25 kg (5 lbs.) CaCl ₂ per 4 L (1 gal.) of water]	399 kg (880 lbs.)	411 kg (906 lbs.)	436 kg (960 lbs.)

IMPORTANT :

- Do not fill tires with water or solution more than 75% of full capacity (to the valve stem level).

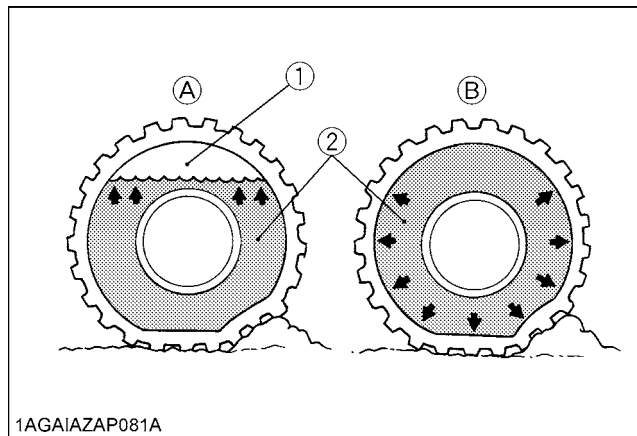

- (1) Air (A) Correct-75% Air compresses like a cushion
 (2) Water (B) Incorrect-100% Full Water can not be compressed

CAB OPERATION

DOOR AND WINDOW

■ Locking and Unlocking the Door

From the outside Insert the key into the door lock. Turn the key clockwise to unlock the door. To lock the door, turn the key in the opposite direction. The key can be removed when it is in the vertical direction.

From the inside Push down the lock knob to lock the door. Pull up the lock knob to unlock the door.

■ Opening the Door

From the outside Unlock the door, and pull the outer door handle.

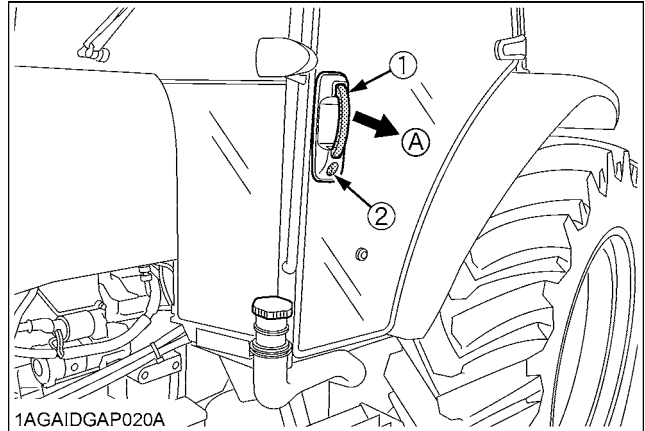

(1) Outer door handle
(2) Door lock

(A) "PULL"

From the inside Unlock the door and pull the inner door handle.

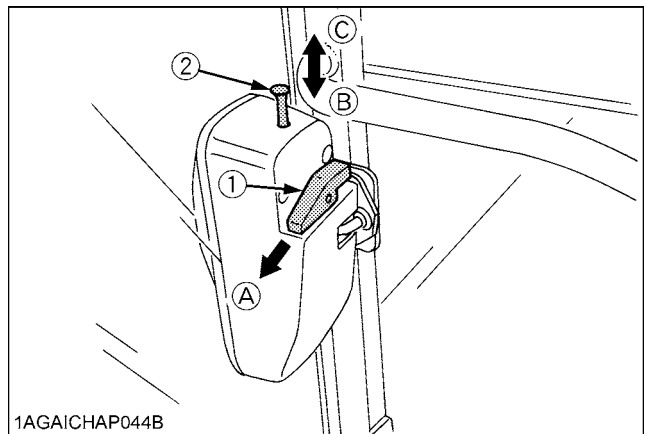

(1) Inner door handle
(2) Lock knob

(A) "PULL"
(B) "PUSH" (Lock)
(C) "PULL" (Unlock)

■Rear Window

Turn the rear window handle clockwise to the vertical position and push the handle. The rear window is opened by the gas spring cylinder.

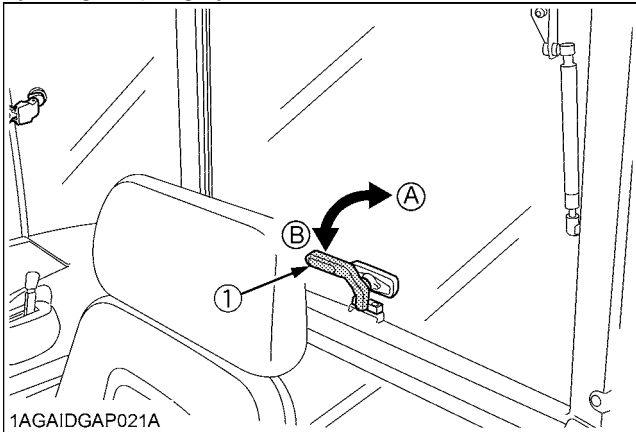

(1) Rear window handle

(A) "OPEN"
(B) "CLOSE"

■Side Window

Pull the side window handle and push the side window to open the window.

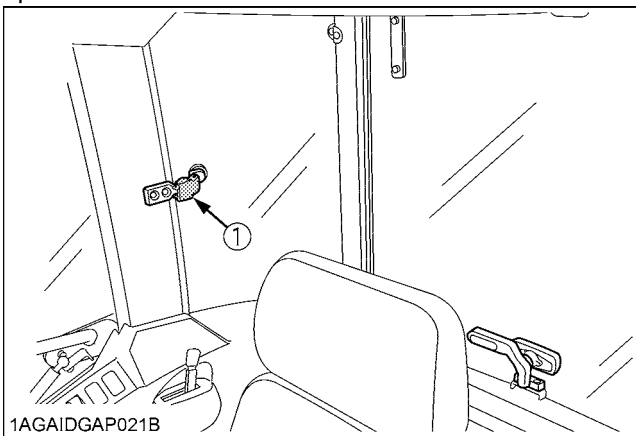

(1) Side window handle

DOME LIGHT

■Dome Light

Sliding the dome light switch will give the following light condition:

- OFF The light does not turn on when the door is opened.
- DOOR The light turns on when the door (LH) is opened. It turns off when the door (LH) is closed.
- ON The light remains on regardless of the door position.

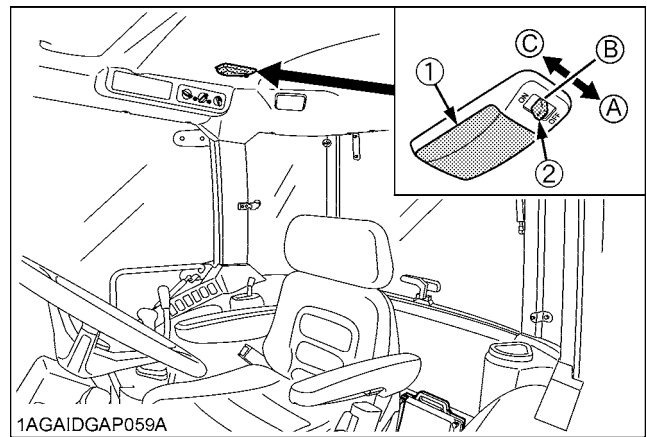

(1) Dome light

(2) Dome light switch

(A) "OFF"

(B) "DOOR"

(C) "ON"

IMPORTANT :

- The battery will discharge if the dome light remains on. Be sure to check the dome light switch position and/or door closure.

WORK LIGHT



CAUTION

To avoid personal injury:

- Do not operate on roads with work lights on. Work lights may blind or confuse operators of oncoming vehicles.

Work Light Switch

Turn on the key switch and press the top half of the work light switch. The work light and the switch's indicator light up. Press the bottom half of the work light switch to turn off the light and indicator.

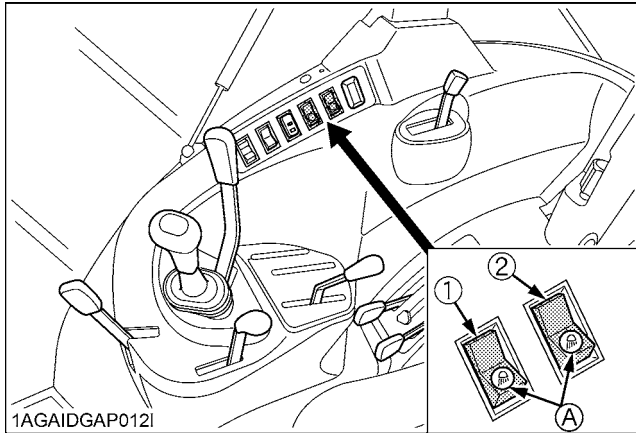

(1) Front work light switch
(2) Rear work light switch

(A) Indicator for work lights

Front Work Light

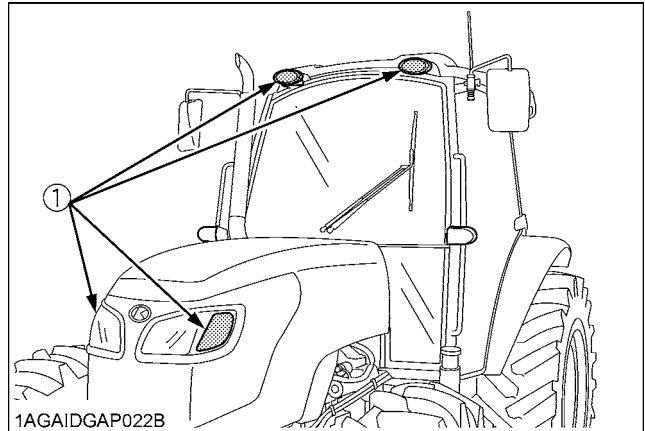

(1) Front work light

Rear Work Light

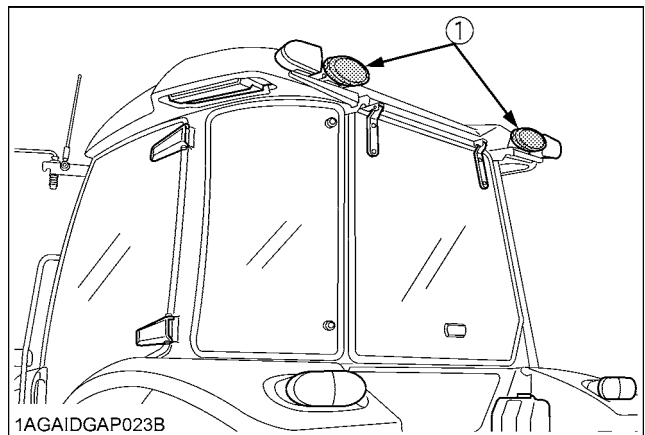

(1) Rear work light

WIPER

■ Front Wiper / Washer Switch

1. Turn on the key switch and press the top half of the wiper switch to the first step, the wiper is activated.
When the switch is pressed further to the second step, washer liquid jets out.
The jetting continues while the switch is pressed and the wiper is activated continuously.
2. Press the bottom half to the first step, the wiper is activated at regular intervals.
When the switch is pressed further to the second step, washer liquid jets out and the wiper is activated at regular intervals.

■ Rear Wiper / Washer Switch (if equipped)

1. Turn on the key switch and press the top half of the wiper switch to the first step, and the wiper is activated.
When the switch is pressed further to the second step, washer liquid jets out.
The jetting continues while the switch is pressed and the wiper is activated continuously.
2. Press the bottom half of the wiper / washer switch, washer liquid only jets out.

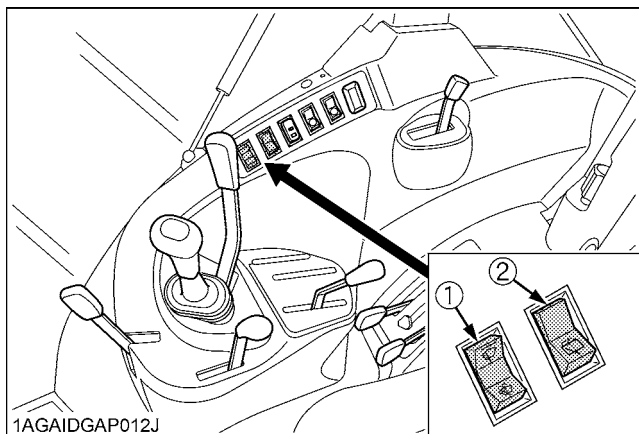

(1) Front wiper / washer switch

(2) Rear wiper / washer switch (if equipped)

■ Using the Wipers in Cold Season

1. While not used in cold season, keep the wiper blades off the windshield to prevent them from being stuck with ice.
2. If the windshield is covered with snow, scrape it off the windshield before using the wipers.
3. If the wiper blades are stuck on the windshield with ice and fail to move, be sure to turn the main key switch to "OFF" and remove the ice off the blades. Then place the main key switch back to "ON".
4. When commercially available cold-season wiper blades are used, make sure their size is the same as or smaller than that of the standard ones.

IMPORTANT :

- In cold season, the wiper blades and the wiper motor might get overloaded causing damage. To avoid this, be sure to take the above precautions.

IMPORTANT :

- Do not activate the wipers when the windows are dry, they may be scratched.
Be sure to jet washer liquid first and then activate the wipers.

AIR CONDITIONER

■ Airflow

Air in the CAB and fresh air introduced into the CAB flow as shown below. Adjust the 7 air ports to obtain the desired condition.

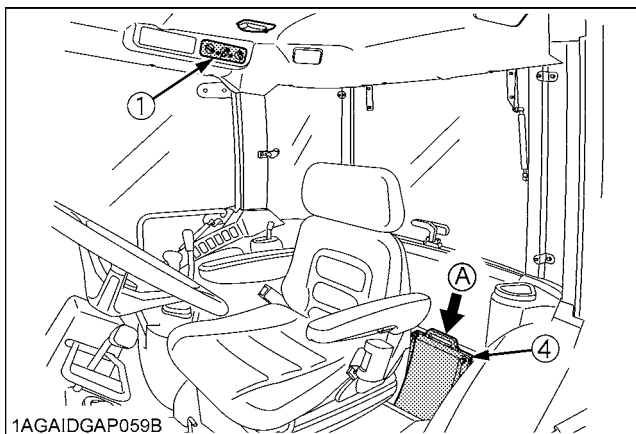
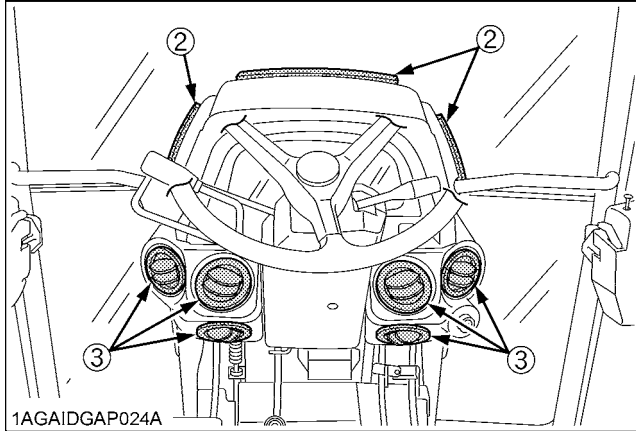

(1) Control panel (A) Inner air recirculation
 (2) Defroster air outlets
 (3) Dashboard air outlets
 (4) Inner air filter

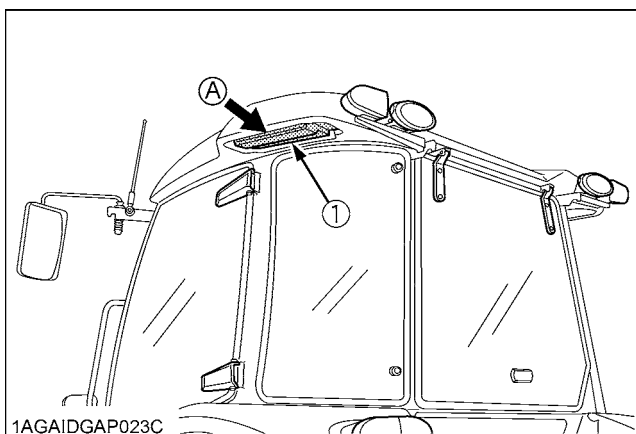

(1) Fresh air filter (A) "FRESH AIR INLET"

IMPORTANT :

- Do not pour water directly into the fresh air port while washing the vehicle.

■ Air Control Vent

◆ Dashboard air outlet

The dashboard air outlets can be independently adjusted as required.

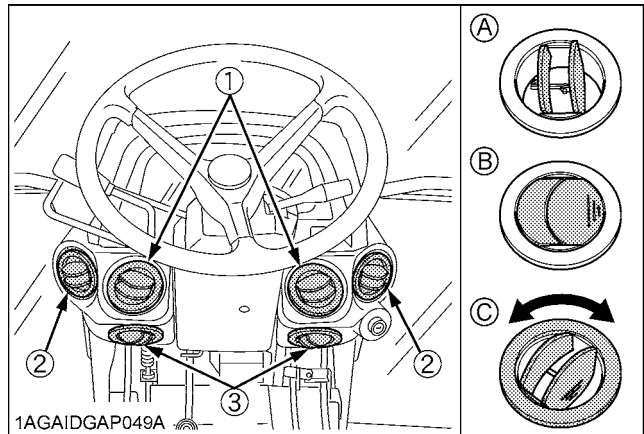

(1) Face area air outlets (A) "OPEN"
 (2) Back area air outlets (B) "SHUT"
 (3) Feet area air outlets (C) "TURN"

⚠ CAUTION

To avoid personal injury;

- Replace the water hoses every two years.
- Daily inspection
 Have the tractor repaired immediately if any of the following defects are discovered. (Such defects may cause burns or injury. They may also cause engine seizure or other serious failure.)
 - Scratches, cracks or swelling in water hoses.
 - Water leakage at water hose joints.
 - Missing or damaged water hose protective wrap or grommets.
 - Loose mounting bolts, damaged brackets.
- Do not touch the water hoses and the heater with your hand. You may get burned.
- If the window fails to defrost in extreme conditions or becomes cloudy when dehumidifying the CAB, wipe off moisture with a soft cloth.
- Do not block all the air outlets of the air conditioner. A problem could occur.

Control Panel

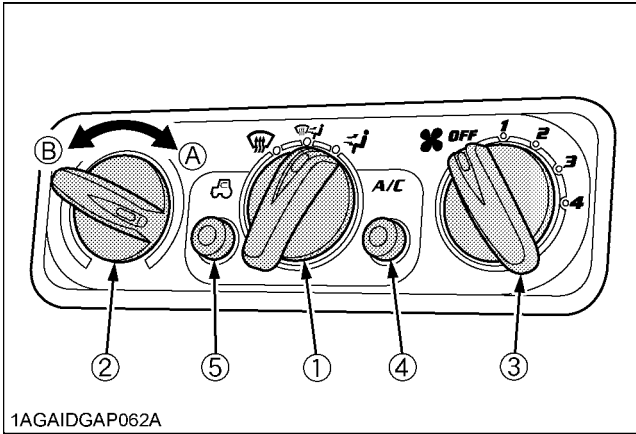

- (1) Mode switch (A) "WARM" (B) "COOL"
- (2) Temperature control dial
- (3) Blower switch
- (4) Air conditioner switch with indicator light
- (5) Recirculation / fresh air selection switch with indicator light

Mode switch

Set the mode switch to the desired position.

- Air is blown from only the dashboard air outlets.
- Air is blown from the dashboard and defroster air outlets.
- Air is blown from only the defroster air outlet.

Temperature Control Dial

Set this dial at the desired position to obtain the optimum air temperature. Turn the dial in the "WARM" direction to obtain warmer air. Turn it in the "COOL" direction to obtain cooler air.

Blower Switch

Air volume can be changed in four steps. At the "4" position, the largest air volume is obtained.

Air Conditioner Switch

Push this switch to activate the air conditioner. An indicator light will light up when the switch is set to "ON". Push the switch again to turn the air conditioner off, in which case the indicator light will be off.

Recirculation / fresh air selection switch

Each time the switch is pressed, the air flow position changes for "RECIRCULATION" or "FRESH AIR". An indicator light will light up when the switch is set to "RECIRCULATION". And the indicator light will be off when the switch is set to "FRESH AIR".

FRESH AIR: Fresh air will flow into the CAB. This is helpful when you work in dusty conditions or if the glass windows get foggy.
(Indicator: OFF)

RECIRCULATION: In-CAB air will be recirculated. This is useful for cooling or heating the CAB quickly or keeping it extra cool or warm.
(Indicator: ON)

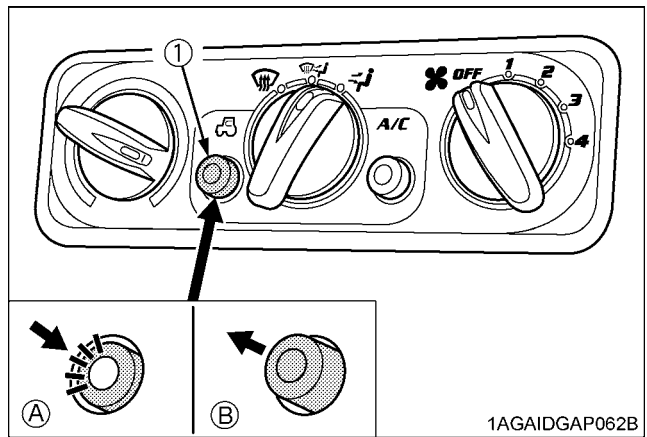

- (1) Recirculation / fresh air selection switch with indicator light
- (A) "RECIRCULATION"
- (B) "FRESH AIR"

NOTE :

- When heating, do not keep the switch at the "RECIRCULATION" position for a long time. The windshield easily gets foggy.
- While working in a dusty conditions, keep the switch at the "FRESH AIR" position. This increases the pressure in the CAB, which helps prevent dust from coming into the CAB.

■ Operation

◆ Heating

1. Set the mode switch to the  position.
2. Set the recirculation / fresh air selection switch to the "FRESH AIR" position. To raise the temperature in the CAB quickly, set this switch to the "RECIRCULATION" position.
3. Adjust the blower (1/2/3/4) switch and the temperature control dial to achieve a comfortable temperature level.

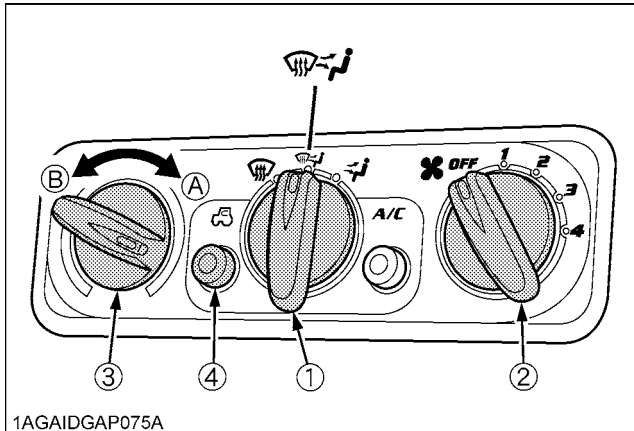

- | | |
|---|------------|
| (1) Mode switch | (A) "WARM" |
| (2) Blower switch | (B) "COOL" |
| (3) Temperature control dial | |
| (4) Recirculation / fresh air selection switch with indicator light | |

4. Adjust the air volume and air direction from the dashboard air outlets. In general, open Feet area air outlets, and shut Face / Back area air outlets.

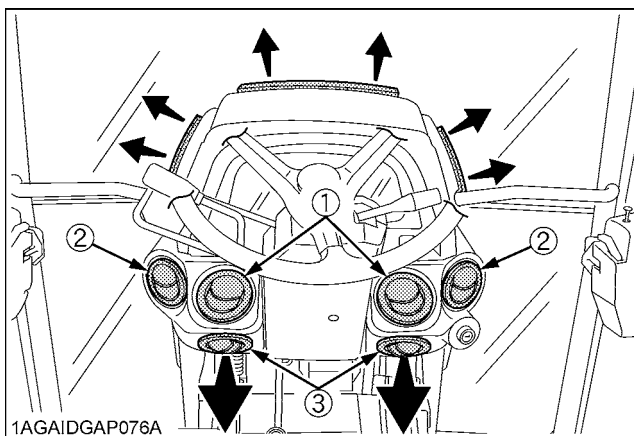

- (1) Face area air outlets
- (2) Back area air outlets
- (3) Feet area air outlets

◆ Cooling or dehumidifying-heating

1. Set the mode switch to the  position.
2. Set the recirculation / fresh air selection switch to the "FRESH AIR" position. To fall the temperature in the CAB quickly, set this switch to the "RECIRCULATION" position.
3. Press and turn on the air-conditioner switch with indicator.
4. Turn on the blower (1/2/3/4) switch.
5. Adjust the temperature control dial to the "COOL" or an intermediate position to achieve a comfortable temperature level.

NOTE :

- In summer when the heater is not used, keep the temperature control dial at the max "COOL" (end of counterclockwise) position. Otherwise, hot air will raise the temperature in the CAB.

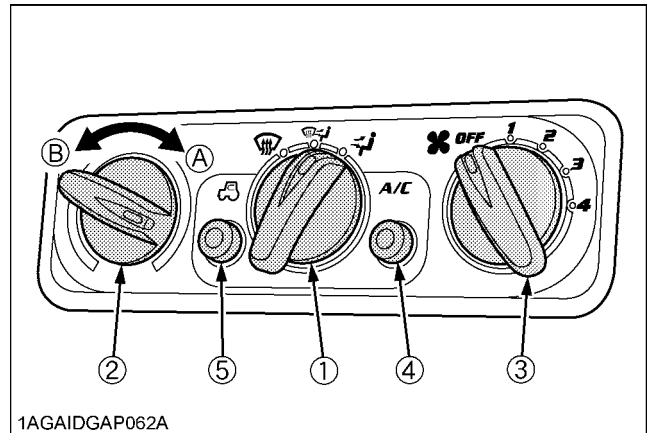

- | | |
|---|------------|
| (1) Mode switch | (A) "WARM" |
| (2) Temperature control dial | (B) "COOL" |
| (3) Blower switch | |
| (4) Air conditioner switch with indicator light | |
| (5) Recirculation / fresh air selection switch with indicator light | |

6. Adjust the air volume and air direction from the dashboard air outlets. In general, the air volume from Face area air outlets is adjusted to increase, and the air volume from Feet area air outlets is adjusted to decrease.

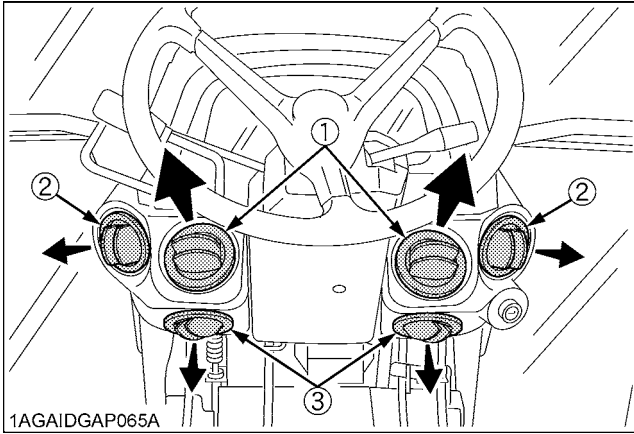

- (1) Face area air outlets
- (2) Back area air outlets
- (3) Feet area air outlets

◆ Defrosting or demisting

To defrost or demist the windshield, take the following steps.

1. Set the mode switch to the position.
2. Set the recirculation / fresh air selection switch to the "FRESH AIR" position.
3. Set the blower switch and the temperature control dial to the "4" and max "WARM" (end of clockwise) positions, respectively.

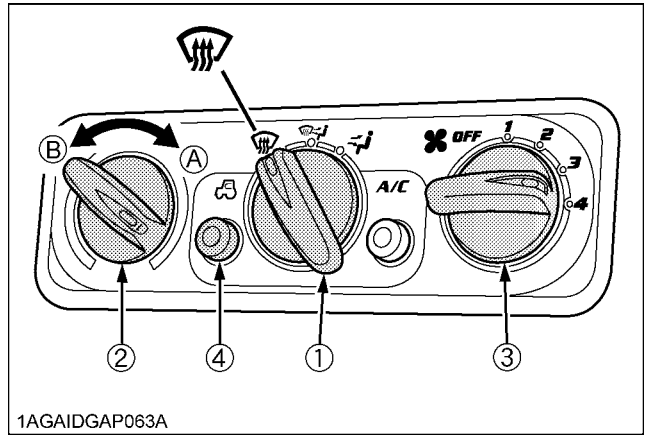

- (1) Mode switch
- (2) Temperature control dial
- (3) Blower switch
- (4) Recirculation / fresh air selection switch with indicator light
- (A) "WARM"
- (B) "COOL"

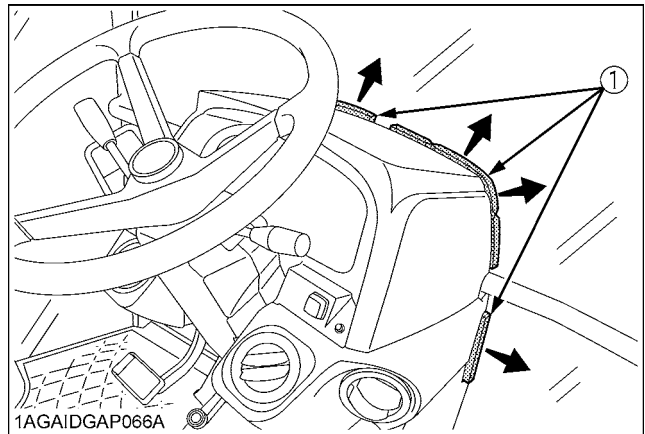

- (1) Defroster air outlet

NOTE :

- If you set the mode switch to position, air will not come out from the dashboard air outlets.

REAR / SIDE DEFOGGER WITH TIMER (if equipped)

To activate the rear / side window defoggers, press the switch marked  while the key switch is in the "ON" position. Then, the yellow light on the switch turns on. After about 15 minutes, the defoggers automatically turn off as well as the yellow light. To turn the defogger off, press the switch once more.

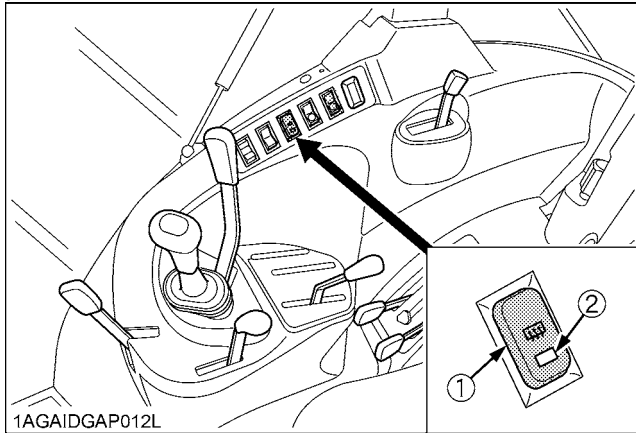

(1) Defogger switch
(2) Yellow light

IMPORTANT :

- The battery will discharge if the defogger and the key switch remain in the "ON" or "ACC" positions with the engine stopped.
Always use the defogger with the engine running.

CIGARETTE LIGHTER

Push the lighter knob down to activate, with the key switch in the "ON" or "ACC" positions.
Lighter will move up when ready to use.

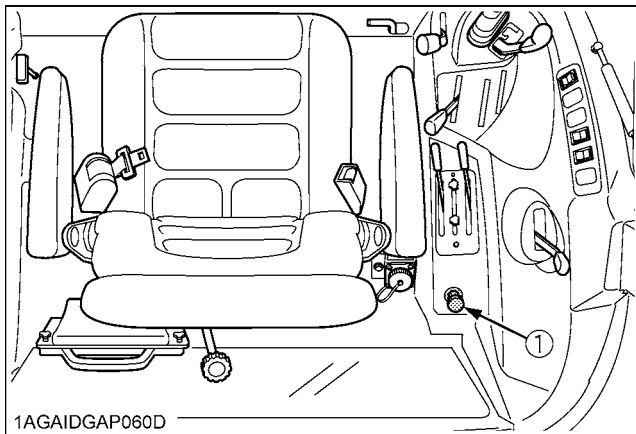

(1) Cigarette lighter

INSTALLING THE IMPLEMENT CONTROL BOX

1. Make an opening in each of the rubber caps or corner plug. Introduce the implement control cable and hydraulic hose through these openings into the CAB.

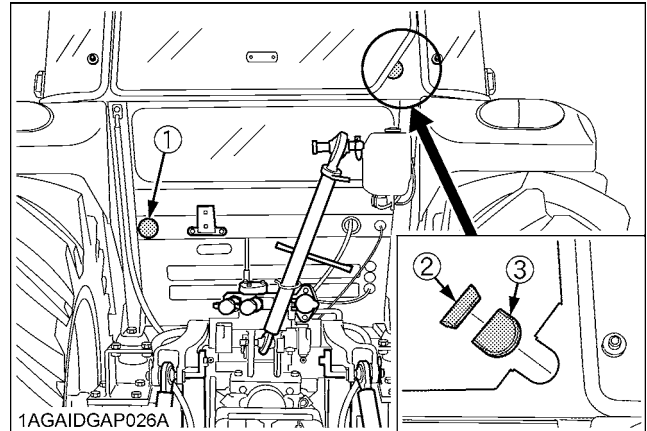

(1) Rubber cap
(2) Cap
(3) Corner plug

■ Electrical Outlet

A electrical outlet is supplied for use with implement.

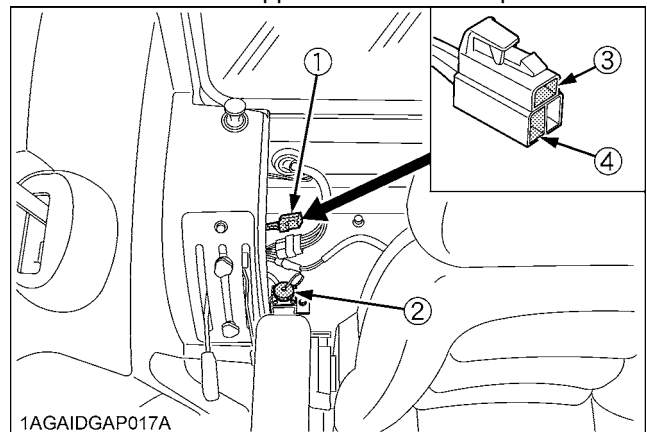

1AGAIDGAP017A

[Air suspension seat type]

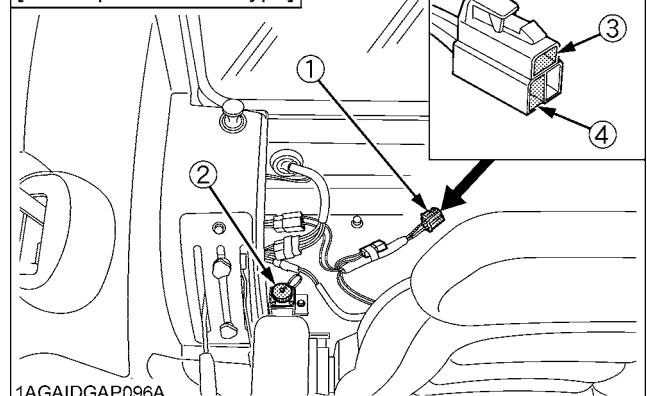

1AGAIDGAP096A

(1) Accessory electrical outlet (15A) (3) Positive (+)
(2) Accessory electrical outlet (30A) (4) Negative (-)

MAINTENANCE

SERVICE INTERVALS

No.	Items		Indication on hour meter													Interval	Ref. page			
			50	100	150	200	250	300	350	400	450	500	550	600	650					700
1	Engine start system	Check	○	○	○	○	○	○	○	○	○	○	○	○	○	○	every 50 Hr	81		
2	Wheel bolt torque	Check	○	○	○	○	○	○	○	○	○	○	○	○	○	○	every 50 Hr	82		
3	Battery condition	Check		○		○		○		○		○		○		every 100 Hr	83	*5		
4	Greasing	---		○		○		○		○		○		○		every 100 Hr	88			
5	Fan belt	Adjust		○		○		○		○		○		○		every 100 Hr	85			
6	Brake Pedal	Adjust		○		○		○		○		○		○		every 100 Hr	86			
7	Clutch pedal [Synchro shuttle model]	Adjust	◎	○		○		○		○		○		○		every 100 Hr	86			
8	Air cleaner element	Primary element	Clean		○		○		○		○		○		○	every 100 Hr	85	*1	◎	
		Replace														every 1 year	99	*2		
		Secondary element	Replace														every 1 year	99		
9	Fuel line	Check		○		○		○		○		○		○		every 100 Hr	87		◎	
		Replace														every 2 years	102	*4		
10	Parking brake	Check		○		○		○		○		○		○		every 100 Hr	87			
11	Toe-in	Adjust				○				○				○		every 200 Hr	90			
12	Fuel tank water	Drain				○				○				○		every 200 Hr	91			
13	Power steering oil line	Check				○				○				○		every 200 Hr	90			
		Replace														every 2 years	102	*4		
14	Radiator hose and clamp	Check				○				○				○		every 200 Hr	89			
		Replace														every 2 years	102			
15	Intake air line	Check				○				○				○		every 200 Hr	90		◎	
		Replace														every 2 years	102	*3		
16	Engine oil	Change	◎					○						○		every 300 Hr	95			

No.	Items		Indication on hour meter													Interval	Ref. page			
			50	100	150	200	250	300	350	400	450	500	550	600	650				700	
17	Hydraulic oil filter	Replace	☉					○							○			every 300 Hr	94	
18	Greasing (2WD front wheel hub)	---								○								every 400 Hr	96	
19	Water separator	Clean								○								every 400 Hr	96	
20	Fuel filter	Replace								○								every 400 Hr	95	@
21	Engine oil filter	Replace	☉												○			every 600 Hr	97	
22	Transmission fluid	Change	☉												○			every 600 Hr	97	
23	Front differential case oil	Change	☉												○			every 600 Hr	98	
24	Front axle gear case oil	Change	☉												○			every 600 Hr	99	
25	Front axle pivot	Adjust													○			every 600 Hr	99	
26	Engine valve clearance	Adjust																every 800 Hr	99	*4
27	Fuel injection nozzle injection pressure	Check																every 1500 Hr	99	*4 @
28	Turbo charger	Check																every 3000 Hr	99	*4 @
29	Injection pump	Check																every 3000 Hr	99	*4 @
30	Intake air heater	Check																every 3000 Hr	99	*4
31	Cooling system	Flush																every 2 years	100	
32	Coolant	Change																every 2 years	100	
33	Master cylinder filter	Clean																every 2 years	102	*4
34	Lift cylinder hose	Replace																every 2 years	102	*4
35	Master cylinder kit	Replace																every 2 years	102	*4
36	Equalizer kit	Replace																every 2 years	102	*4
37	Brake seal 1 and 2	Replace																every 2 years	102	*4
38	Fuel system	Bleed																Service as required	102	
39	Brake system	Bleed																Service as required	103	*4
40	Clutch housing water	Drain																Service as required	103	

No.	Items		Indication on hour meter													Interval	Ref. page		
			50	100	150	200	250	300	350	400	450	500	550	600	650			700	
41	Fuse	Replace																Service as required	103
42	Light bulb	Replace																Service as required	105

No.	Items		Indication on hour meter													Interval	Ref. page		
			50	100	150	200	250	300	350	400	450	500	550	600	650			700	
1	Inner air filter	Clean				○				○						○		every 200 Hr	91
2	Fresh air filter	Clean				○				○						○		every 200 Hr	92
3	Air conditioner condenser	Clean				○				○						○		every 200 Hr	93
4	Air conditioner drive belt	Adjust				○				○						○		every 200 Hr	93
5	Air conditioner pipes and hoses	Check																every 1 year	99
		Replace																every 2 years	102
6	CAB isolation cushion	Check																every 1 year	99
7	Washer liquid	Add																Service as required	106
8	Refrigerant (gas)	Check																Service as required	106

IMPORTANT :

- The jobs indicated by ○ must be done after the first 50 hours of operation.
- *1 Air cleaner should be cleaned more often in dusty conditions than in normal conditions.
- *2 Every year or every 6 times of cleaning.
- *3 Replace only if necessary.
- *4 Consult your local KUBOTA Dealer for this service.
- *5 When the battery is used for less than 100 hours per year, check the battery condition by reading the indicator annually.
- The items listed above (@ marked) are registered as emission related critical parts by KUBOTA in the U.S.EPA nonroad emission regulation. As the engine owner, you are responsible for the performance of the required maintenance on the engine according to the above instruction.
Please see the Warranty Statement in detail.

LUBRICANTS

No.	Locations	Capacities		Lubricants	
		M8540	M9540		
1	Fuel	110 L (29.1 U.S.gals.)		No.2-D diesel fuel No.1-D diesel fuel if temperature is below -10 °C (14 °F)	
2	Coolant	9 L (9.5 U.S.qts.) (Recovery tank: 1.0 L (1.1 U.S.qts.))		Fresh clean soft water with anti-freeze	
3	Washer liquid	1.3 L (1.4 U.S.qts.)		Automobile washer liquid	
4	Engine crankcase (with filter)	10.7 L (11.3 U.S.qts.)		<ul style="list-style-type: none"> Engine oil: API Service Classification 	CF or CI-4 [External EGR type engine]
				Above 25 °C (77 °F)	SAE30, SAE10W-30 or 15W-40
				0 to 25 °C (32 to 77 °F)	SAE20, SAE10W-30 or 15W-40
				Below 0 °C (32 °F)	SAE10W, SAE10W-30 or 15W-40
5	Transmission case	60 L (63.4 U.S.qts.)		<ul style="list-style-type: none"> KUBOTA SUPER UDT-2 fluid 	
6	Front differential case oil [4WD]	6.0 L (6.3 U.S.qts.)		<ul style="list-style-type: none"> KUBOTA SUPER UDT-2 fluid or SAE 80 - SAE 90 gear oil 	
7	Front axle gear case oil [4WD]	3.5 L (3.7 U.S.qts.)			
8	Greasing	No. of greasing points		Capacity	Type of grease
	Top link	1		Until grease overflows.	Multipurpose Grease NLGI-2 OR NLGI-1(GC-LB)
	Top link bracket	2			
	Lift rod	2			
	Hydraulic lift cylinder pin	4			
	Front axle gear case support [4WD]	2			
	Front axle support	2			
	Front wheel hub [2WD]	2			
	Knuckle shaft [2WD]	2			
	Steering joint shaft	1			
Battery terminal	2		A small amount		

NOTE :

The product name of KUBOTA genuine UDT fluid may be different from that in the Operator's Manual depending on countries or territories. Consult your local KUBOTA Dealer for further details.

NOTE :**◆ Engine Oil:**

- Oil used in the engine should have an American Petroleum Institute (API) service classification and Proper SAE Engine Oil according to the ambient temperatures as shown above:
- With the emission control now in effect, the CF-4 and CG-4 lubricating oils have been developed for use of a low-sulfur fuel on on-road vehicle engines. When an off-road vehicle engine runs on a high-sulfur fuel, it is advisable to employ the "CF or better" lubricating oil with a high Total Base Number (TBN of 10 minimum).
- Refer to the following table for the suitable API classification engine oil according to the engine type (with internal EGR, external EGR or non-EGR) and the fuel (low-sulfur or high-sulfur fuel).

Fuel used	Engine oil classification (API classification)	
	Oil class of engines except external EGR	Oil class of engines with external EGR
High Sulfur Fuel [$\geq 0.05\%$ (500 ppm)]	CF (If the "CF-4, CG-4, CH-4 or CI-4" lubricating oil is used with a high-sulfur fuel, change the lubricating oil at shorter intervals. (approximately half))	---
Low Sulfur Fuel [$<0.05\%$ (500 ppm)] or Ultra Low Sulfur Fuel [$<0.0015\%$ (15 ppm)]	CF, CF-4, CG-4, CH-4 or CI-4	CF or CI-4 (Class CF-4, CG-4 and CH-4 engine oils cannot be used on EGR type engines)

EGR: Exhaust Gas Re-circulation

- The CJ-4 engine oil is intended for DPF (Diesel Particulate Filter) type engines, and cannot be used on this tractor.

◆ Fuel:

- Cetane number of 45 minimum. Cetane number greater than 50 is preferred, especially for temperatures below -20°C (-4°F) or elevations above 1500 m (5000ft).
- If diesel fuel with sulfur content greater than 0.5% (5000 ppm) sulfur content is used, reduce the service interval for engine oil and filter by 50%.
- NEVER use diesel fuel with sulfur content greater than 0.05% (500 ppm) for EXTERNAL EGR type engine.
- DO NOT use diesel fuel with sulfur content greater than 1.0% (10000 ppm).
- Diesel fuels specified to EN 590 or ASTM D975 are recommended.
- No.2-D is a distillate fuel of lower volatility for engines in industrial and heavy mobile service. (SAE J313 JUN87)

◆ Transmission Oil:

*KUBOTA Super UDT-2: For an enhanced ownership experience, we highly recommend Super UDT-2 to be used instead of standard hydraulic/transmission fluid.

Super UDT-2 is a proprietary KUBOTA formulation that delivers superior performance and protection in all operating conditions.

Regular UDT is also permitted for use in this machine.

- Indicated capacities of water and oil are manufacturer's estimate.

PERIODIC SERVICE



CAUTION

To avoid personal injury:

- Do not work under any hydraulically supported devices. They can settle, suddenly leak down, or be accidentally lowered. If necessary to work under tractor or any machine elements for servicing or adjustment, securely support them with stands or suitable blocking beforehand.

HOW TO OPEN THE HOOD



CAUTION

To avoid personal injury from contact with moving parts;

- Never open the hood while the engine is running.
- Do not touch muffler or exhaust pipes while they are hot; Severe burns could result.
- Hold the hood with other hand while unlocking release lever.

■ Hood

To open the hood, hold the hood and pull the release lever and open the hood.

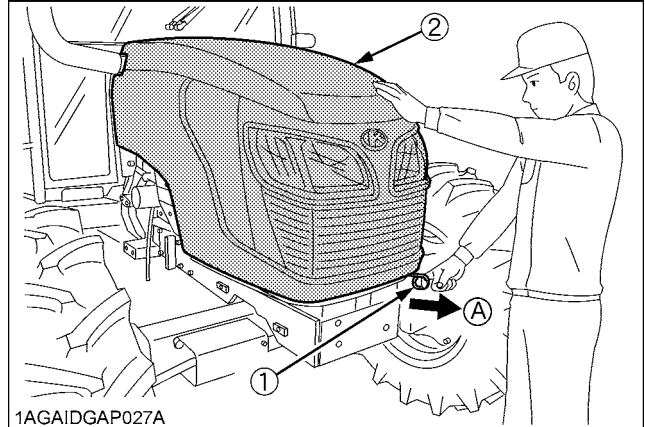

(1) Release lever

(A) "PULL"

(2) Hood

NOTE :

- To close the hood, push the hood into position using both hands.

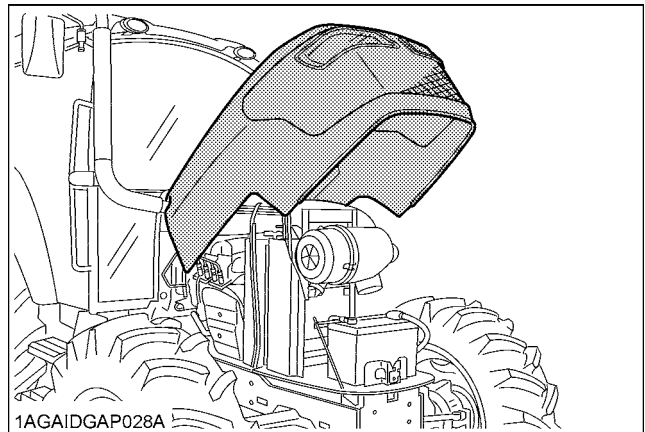

DAILY CHECK

For your own safety and maximum service life of the machine, make a through daily inspection before operating the machine to start the engine.



CAUTION

To avoid personal injury:

- Be sure to check and service the tractor on a flat place with the engine shut off and the parking brake "ON".

■ Walk Around Inspection

Look around and under the tractor for such items as loose bolts, trash build-up, oil or coolant leaks, broken or worn parts.

■ Checking and Refueling



CAUTION

To avoid personal injury:

- Do not smoke while refueling.
- Be sure to stop the engine before refueling.

1. Check the amount of fuel by fuel gauge.
2. When the fuel warning indicator lights up, it is time to add fuel.

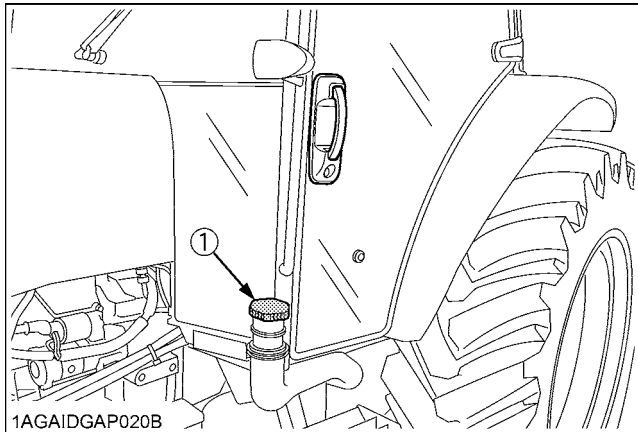

(1) Fuel tank cap

Fuel tank capacity	110 L (29.1 U.S.gals.)
--------------------	------------------------

IMPORTANT :

- Do not permit dirt or trash to get into the fuel system.
- Be careful not to let the fuel tank become empty, otherwise air will enter the fuel system, necessitating bleeding before next engine start.
- Be careful not to spill during refueling. If a spill should occur, wipe it off at once, or it may cause a fire.
- To prevent condensation (water) accumulation in the fuel tank, fill the tank before parking overnight.

■ Checking Water Separator

1. As water is collected in the water separator, the red float is raised.
2. When the red float has reached the white line, close the fuel cock, loosen the retainer ring, take out the cup, and clean the cup. Be careful not to break the element.
3. Place the cup back into position. Bleed the fuel system.
(See "SERVICE AS REQUIRED" in "PERIODIC SERVICE" section.)

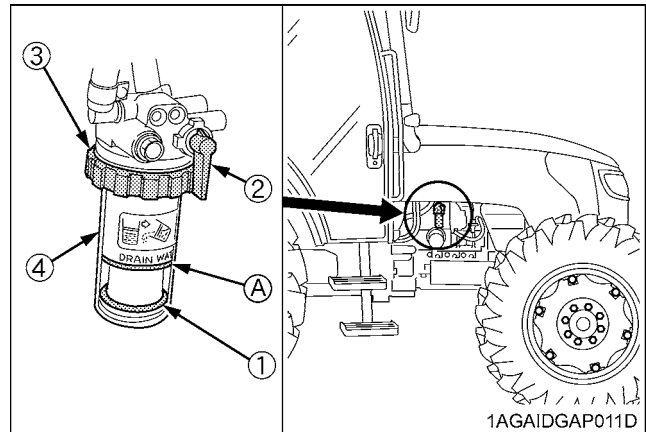

- (1) Red float
(2) Fuel cock
(3) Retainer ring
(4) Cup

(A) "WHITE LINE"

IMPORTANT :

- If water is drawn through to the fuel pump, extensive damage will occur.

■ Checking Engine Oil Level

⚠ CAUTION

To avoid personal injury:

- Be sure to stop the engine before checking the oil level.

1. Park the machine on a flat surface.
2. Check engine oil before starting the engine or 5 minutes or more after the engine has stopped.
3. To check the oil level, draw out the dipstick, wipe it clean, replace it, and draw it out again. Check to see that the oil level lies between the two notches. If the level is too low, add new oil to the prescribed level at the oil inlet.
(See "LUBRICANTS" in "MAINTENANCE" section.)

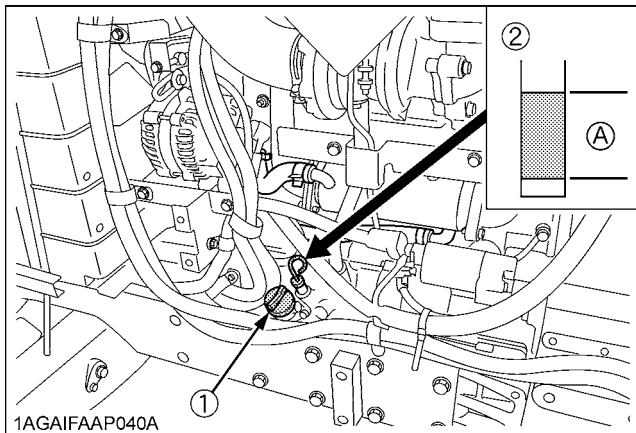

(1) Oil inlet (A) Oil level is acceptable within this range.
(2) Dipstick

IMPORTANT :

- When using an oil of different maker or viscosity from the previous one, remove all of the old oil. Never mix two different types of oil.
- If oil level is low, do not run engine.

■ Checking Transmission Fluid Level

1. Park the machine on a flat surface, lower the implement and shut off engine.
2. To check the oil level, draw out the dipstick, wipe it clean, replace it, and draw it out again. Check to see that the oil level lies between the two notches. If the level is too low, add new oil to the prescribed level at the oil inlet.
(See "LUBRICANTS" in "MAINTENANCE" section.)

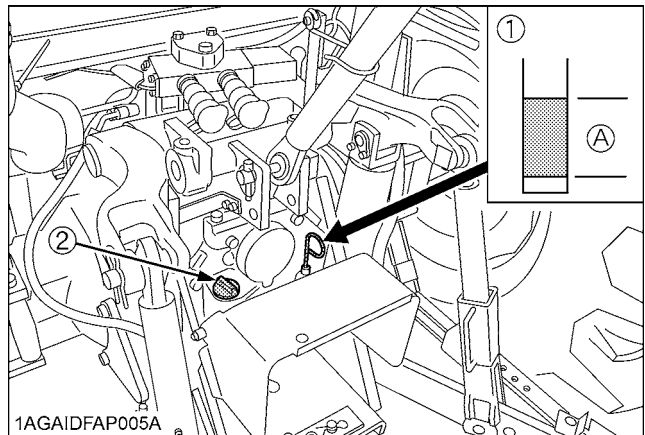

(1) Dipstick (A) Oil level is acceptable within this range.
(2) Oil inlet

IMPORTANT :

- If oil level is low, do not run engine.

■ **Checking Coolant Level**

CAUTION

To avoid personal injury:

- Do not remove radiator cap while coolant is hot. When cool, slowly rotate cap to the first stop and allow sufficient time for excess pressure to escape before removing the cap completely.

1. Check to see that the coolant level is between the "FULL" and "LOW" marks of recovery tank.
2. When the coolant level drops due to evaporation, add soft water only up to the full level.
In case of leakage, add anti-freeze and soft water in the specified mixing ratio up to the full level.
(See "Flushing Cooling System and Changing Coolant" in "EVERY 2 YEARS" in "PERIODIC SERVICE" section.)

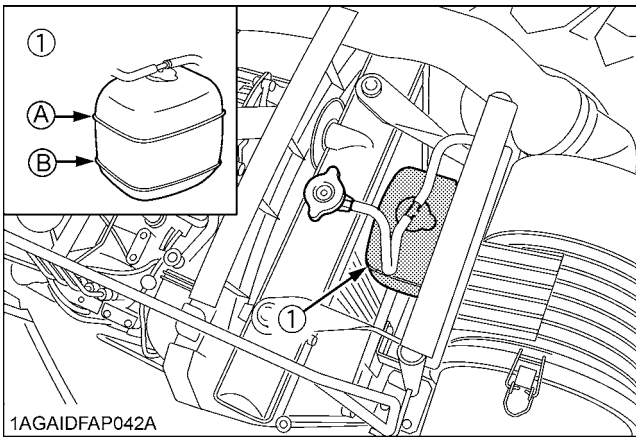

(1) Recovery tank

(A) "FULL"
(B) "LOW"

IMPORTANT :

- If the radiator cap has to be removed, follow the caution above and securely retighten the cap.
- Use clean, fresh soft water and anti-freeze to fill the recovery tank.
- If water should leak, consult your local KUBOTA Dealer.

■ **Cleaning Evacuator Valve**

Open the evacuator valve to get rid of large particles of dust and dirt.

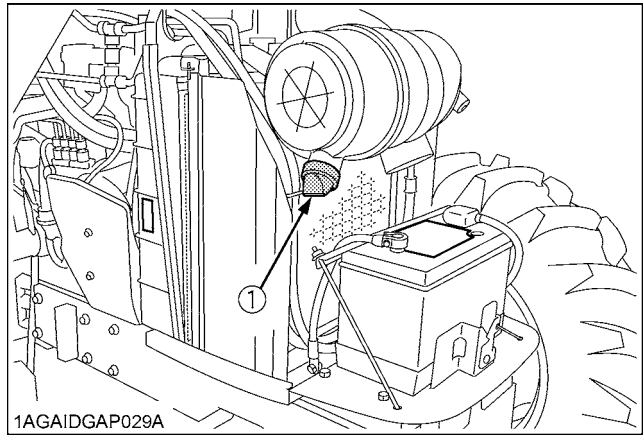

(1) Evacuator valve

■ **Cleaning Grill, Radiator Screen, Oil Cooler and Battery Mount**

CAUTION

To avoid personal injury:

- Be sure to stop the engine before removing the screen.
- The condenser and receiver become hot while the air conditioner is running. Before checking or cleaning them, wait enough until they cool down.

◆ **Opening the panel**

1. Detach the side cover.
2. To open the panel, pull its front outward.
3. To close the panel, push it inward to get locked and attach the side cover.

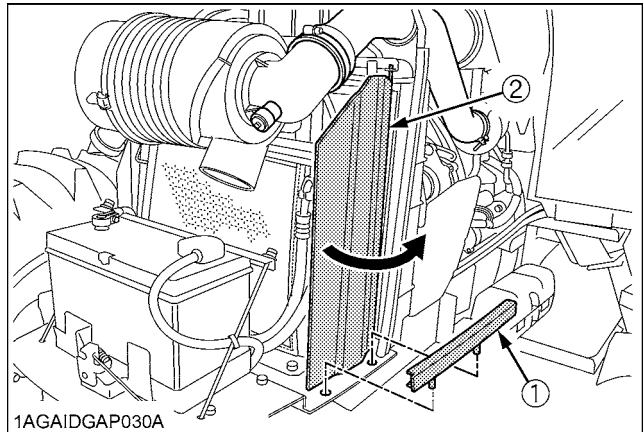

(1) Side cover

(2) Panel

◆ **Detaching the panel**

1. Raise the panel until pin (A) clears the hole, and take out the panel.
2. Attaching the panel is performed vice versa.

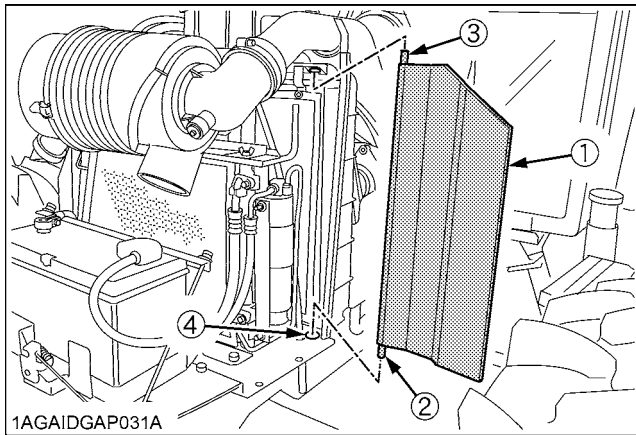

- (1) Panel
- (2) Pin (A)
- (3) Pin (B)
- (4) Hole

◆ **Sliding the air conditioner condenser**

1. Loosen the wing nut.
2. Hold the handle, slide the air conditioner condenser assembly toward yourself.

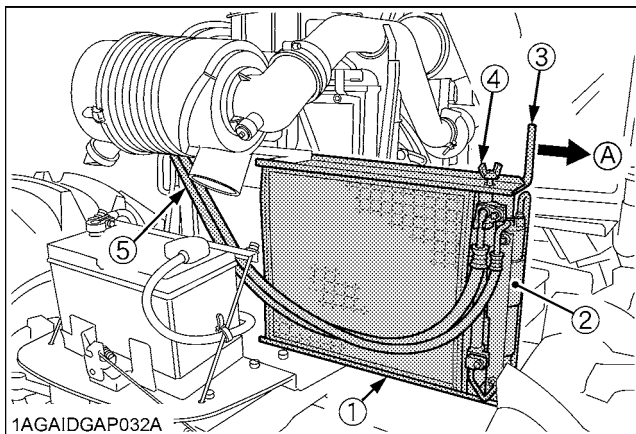

- (1) Condenser
- (2) Receiver
- (3) Handle
- (4) Wing nut
- (5) Air conditioner hose

(A) "PULL"

IMPORTANT :

- Do not hold the air conditioner receiver or the air conditioner pipes when sliding out the condenser for cleaning.

◆ **Cleaning**

1. Check front grill to be sure it is clean from debris.
2. Detach the radiator screen and remove all foreign materials.
3. Check oil cooler and battery mount to be sure they are clean from debris.

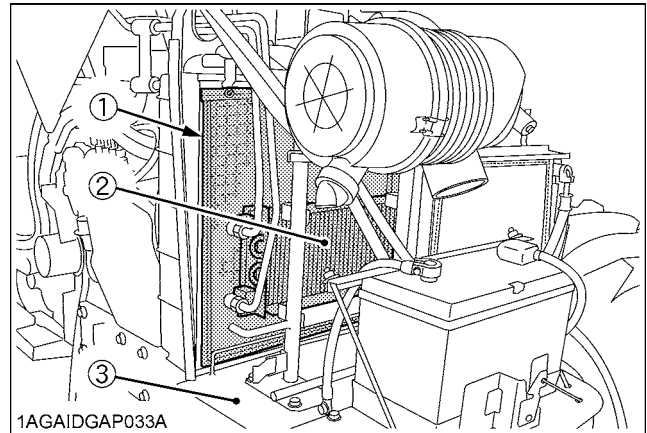

- (1) Radiator screen
- (2) Oil cooler
- (3) Battery mount

IMPORTANT :

- Grill and screen must be clean from debris to prevent engine from overheating and to allow good air intake for air cleaner.

■ Cleaning Air Conditioner Condenser Screen



CAUTION

To avoid personal injury:

- Be sure to stop the engine before removing the screen.

1. Loosen the wing nut.
2. Hold the handle, slide the air conditioner condenser assembly toward yourself.
3. Detach the air conditioner condenser screen and remove all foreign materials.

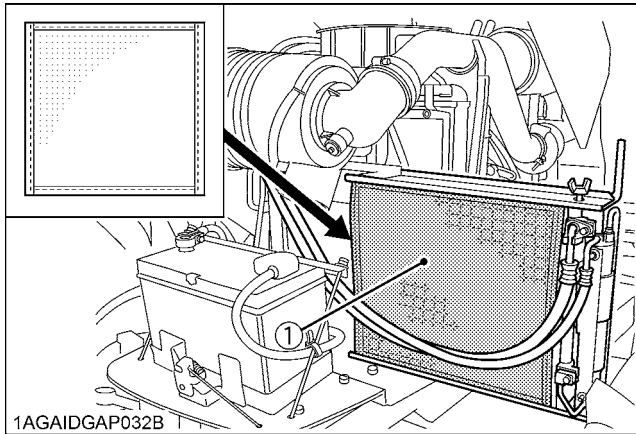

(1) Air conditioner condenser screen

■ Checking Dust Indicator

There is a dust indicator on the air cleaner body. If the red signal on the dust indicator is visible, clean the element immediately. (See "Cleaning Air Cleaner Primary Element" in "EVERY 100 HOURS" in "PERIODIC SERVICE" section.) Reset the red signal by pushing a "RESET" button after cleaning.

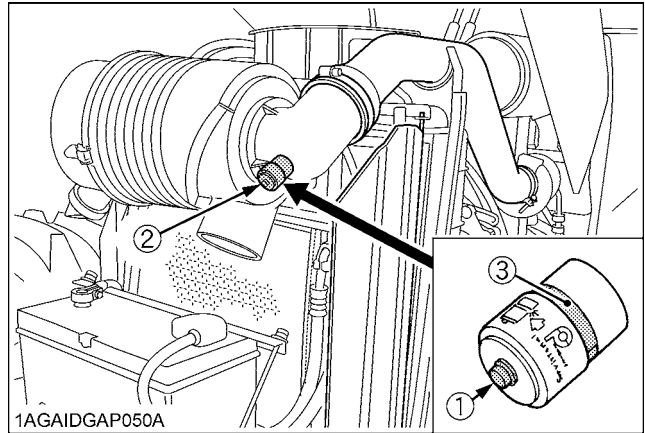

- (1) "RESET" button
- (2) Dust indicator
- (3) Red signal

■ Checking Brake Pedal [Hydraulic Shuttle model]



WARNING

To avoid personal injury:

- Be sure brake pedals have equal adjustment when using locked together. Incorrect or unequal brake pedal adjustment can cause the tractor to swerve or roll-over.

1. Inspect the brake pedals for free travel, and smooth operation.
2. Adjust if incorrect measurement is found:
(See "Adjusting Brake Pedal" in "EVERY 100 HOURS" in "PERIODIC SERVICE" section.)

■ Checking Brake Pedals and Clutch Pedal [Synchro Shuttle model]



WARNING

To avoid personal injury:

- Be sure brake pedals have equal adjustment when using locked together. Incorrect or unequal brake pedal adjustment can cause the tractor to swerve or roll-over.

1. Inspect the brake and clutch pedals for free travel, and smooth operation.
2. Adjust if incorrect measurement is found: (See "Adjusting Clutch Pedal" and "Adjusting Brake Pedal" in "EVERY 100 HOURS" in "PERIODIC SERVICE" section.)

■ Checking Gauges, Meter and Easy Checker(TM)

1. Inspect the instrument panel for broken gauge(s), meter(s) and Easy Checker(TM) lamps.
2. Replace if broken.

■ Checking Head Light, Hazard Light etc.

1. Inspect the lights for broken bulbs and lenses.
2. Replace if broken.

■ Checking Seat Belt

1. Always check condition of seat belt attaching hardware before operating tractor.
2. Replace if damaged.

EVERY 50 HOURS

■ Checking Engine Start System



CAUTION

To avoid personal injury:

- Do not allow anyone near the tractor while testing.
- If the tractor does not pass the test, do not operate the tractor.

◆ Preparation before testing.

1. Place all control levers in the "NEUTRAL" position.
2. Set the parking brake and stop the engine.

◆ Test: Switch for the shuttle shift lever.

1. Follow the instruction of "PARKING THE TRACTOR". (See "PARKING THE TRACTOR" in "SAFE OPERATION" section.)
2. Sit on the operator's seat.

3. Shift the shuttle shift lever to the forward or reverse position.
4. Depress the clutch pedal fully.
5. Disengage the PTO clutch control switch or lever.
6. Turn the key to "START" position.
7. The engine must not crank.
8. If it cranks, consult your local KUBOTA Dealer for this service.

◆ Test: Switch for the PTO clutch control switch or lever.

1. Follow the instruction of "PARKING THE TRACTOR". (See "PARKING THE TRACTOR" in "SAFE OPERATION" section.)
2. Sit on the operator's seat.
3. Engage the PTO clutch control switch or lever.
4. Depress the clutch pedal fully.
5. Shift the shuttle shift lever to the neutral position.
6. Turn the key to "START" position.
7. The engine must not crank.
8. If it cranks, consult your local KUBOTA Dealer for this service.

◆ Test: Checking Operator Presence Control (O.P.C.) System.

1. Follow the instruction of "PARKING THE TRACTOR". (See "PARKING THE TRACTOR" in "SAFE OPERATION" section.)
2. Sit on the operator's seat.
3. Make sure the PTO drive shaft is disconnected from any attached implement.
4. Start the engine.
5. Engage the PTO clutch control switch or lever. The PTO should begin to rotate. Disengage the PTO clutch control switch or lever.
6. While lifting yourself from the seat, engage the PTO clutch control switch or lever.
 - (1) The PTO should begin to rotate and a buzzer should sound.
 - (2) Disengage the PTO clutch control switch or lever.
 - (3) If the buzzer does not sound, shut off the engine and consult your local KUBOTA Dealer for immediate servicing of the PTO OPC.
7. If the PTO OPC is operating properly, shut off the engine, and reconnect the implement drive shaft to the PTO. Restart the engine per the available instructions.



WARNING

To avoid serious injury or death:

- Before checking the PTO OPC, make sure that the PTO drive shaft should be disconnected from the tractor.
- If the buzzer does not sound during the PTO OPC check procedure, shut off engine and consult your local KUBOTA Dealer for immediate servicing of the PTO OPC.
- The unit should not be operated until servicing is completed.

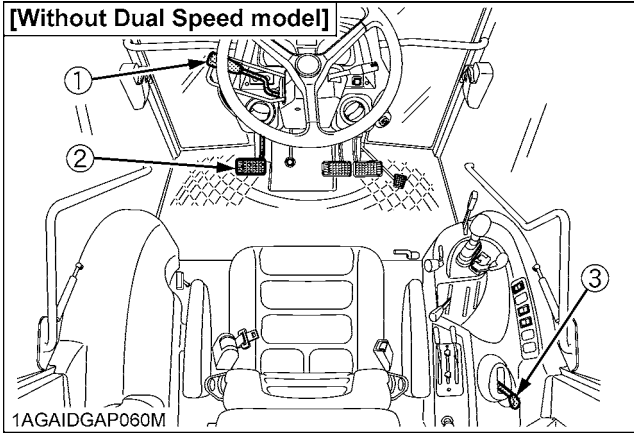

- (1) Shuttle shift lever
- (2) Clutch pedal
- (3) PTO clutch control lever

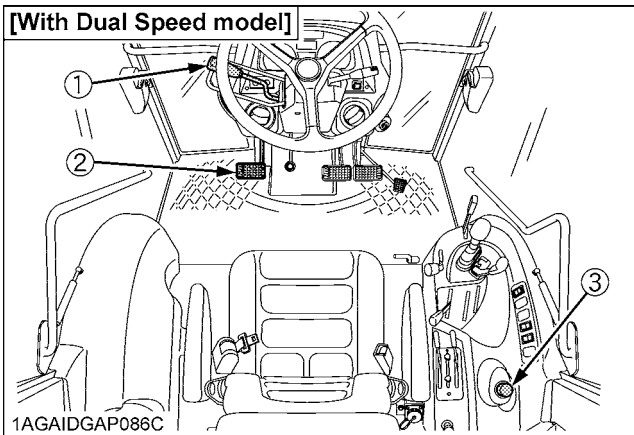

- (1) Shuttle shift lever
- (2) Clutch pedal
- (3) PTO clutch control switch

■ Checking Wheel Bolt Torque

⚠ CAUTION

To avoid personal injury:

- Never operate tractor with a loose rim, wheel, or axle.
- Any time bolts and nuts are loosened, retighten to specified torque.
- Check all bolts and nuts frequently and keep them tight.

Check wheel bolts and nuts regularly especially when new. If they are loose, tighten them as follows.

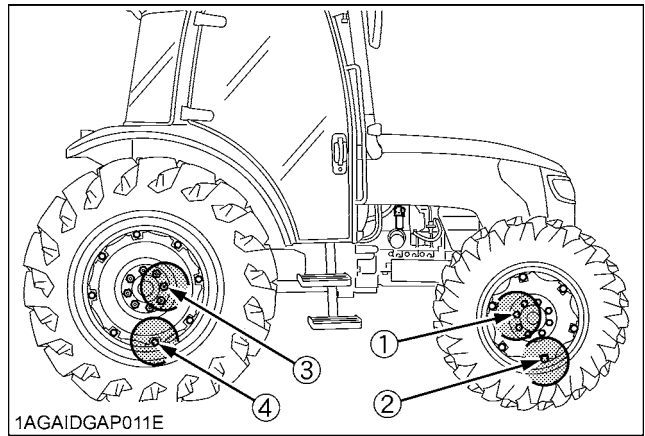

N-m (kgf-m) [ft-lbs.]

	(1)	(2)	(3)	(4)
2WD	168 to 196 (17.1 to 20.0) [124 to 145]	---	260 to 304 (26.5 to 31.0) [192 to 224]	Steel disk 244 (24.9) [180]
4WD	260 to 304 (26.5 to 31.0) [192 to 224]	244 (24.9) [180]		Cast iron disk 260 to 304 (26.5 to 31.0) [192 to 224]

EVERY 100 HOURS

■ Checking Battery Condition



DANGER

To avoid the possibility of battery explosion:
For the refillable type battery, follow the instructions below.

- Do not use or charge the refillable type battery if the fluid level is below the LOWER (lower limit level) mark. Otherwise, the battery component parts may prematurely deteriorate, which may shorten the battery's service life or cause an explosion. Check the fluid level regularly and add distilled water as required so that the fluid level is between the UPPER and LOWER levels.



CAUTION

To avoid personal injury:

- Never remove the battery cap while the engine is running.
- Keep electrolyte away from eyes, hands and clothes. If you are splattered with it, wash it away completely with water immediately and get medical attention.
- Keep open sparks and flames away from the battery at all times. Hydrogen gas mixed with oxygen becomes very explosive.
- Wear eye protection and rubber gloves when working around battery.

The factory-installed battery is of non-refillable type. If the indicator turns white, do not charge the battery but replace it with new one.

Mishandling the battery shortens the service life and adds to maintenance costs.

The original battery is maintenance free, but needs some servicing.

If the battery is weak, the engine will be difficult to start and the lights will be dim. It is important to check the battery periodically.

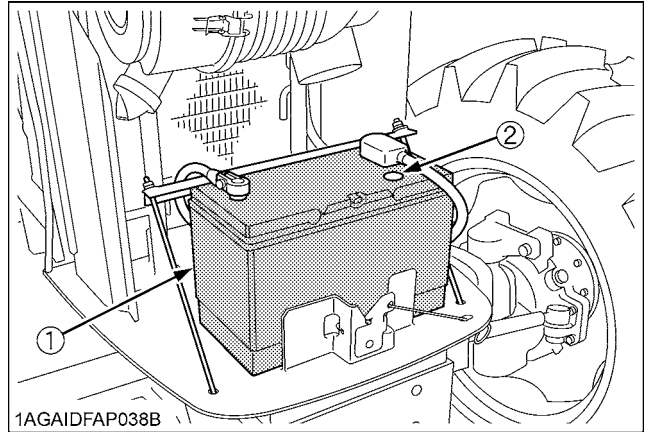

1AGAI DFAP038B

- (1) Battery
(2) Indicator

◆ How to read the indicator

Check the battery condition by reading the indicator.

State of indicator display	
Green	Specific gravity of electrolyte and quality of electrolyte are both in good condition.
Black	Needs charging battery.
White	Needs replacing battery.

◆ Battery Cable Connections

1. Be sure to wire the battery cable as shown in the figure.
2. Fix the positive cable in the cord band.
3. Tighten the terminal until the stopper comes in contact.

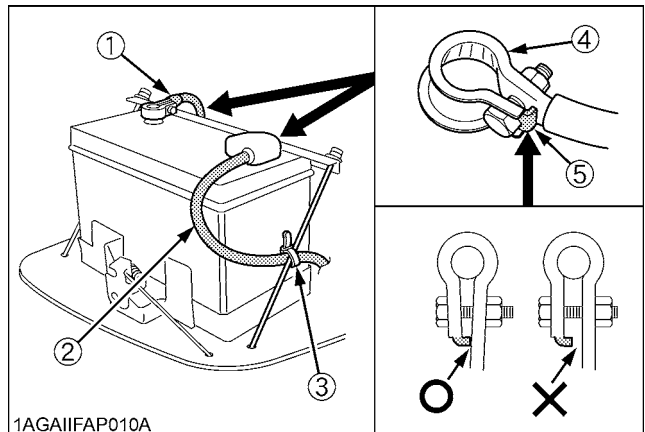

1AGAI IFAP010A

- (1) Negative cable (4) Terminal
(2) Positive cable (5) Stopper
(3) Cord band

◆ Battery Charging



CAUTION

To avoid personal injury:

- When the battery is being activated, hydrogen and oxygen gases in the battery are extremely explosive. Keep open sparks and flames away from the battery at all times, especially when charging the battery.
- When charging the battery, ensure the vent caps are securely in place. (if equipped)
- When disconnecting the cable from the battery, start with the negative terminal first. When connecting the cable to the battery, start with the positive terminal first.
- Never check battery charge by placing a metal object across the posts. Use a voltmeter or hydrometer.

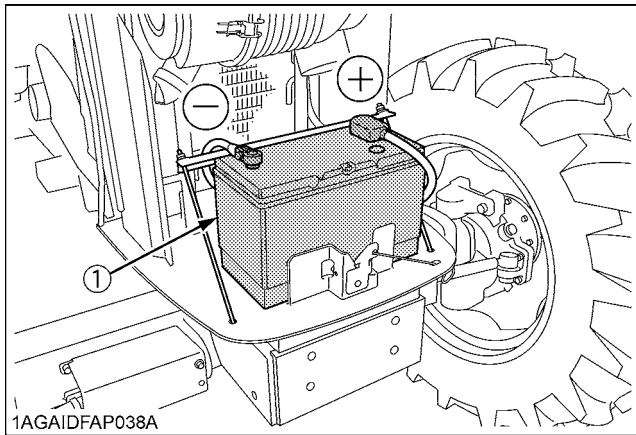

(1) Battery

1. To slow charge the battery, connect the battery positive terminal to the charger positive terminal and the negative to the negative, then recharge in the standard fashion.
2. A boost charge is only for emergencies. It will partially charge the battery at a high rate and in a short time. When using a boost-charged battery, it is necessary to recharge the battery as early as possible. Failure to do this will shorten the battery's service life.
3. The battery is charged if the indicator display turns green from black.
4. When exchanging an old battery for a new one, use battery of equal specification shown in **table 1**.

Table 1

Battery Type	Volts (V)	Capacity at 5H.R(A.H)
GP31 (105E41R)	12	85.3
Reserve Capacity (min)	Cold Cranking Amps	Normal Charging Rate (A)
160	900	11

◆ Direction for Storage

1. When storing the tractor for long periods of time, remove the battery from tractor, adjust the electrolyte to the proper level and store in a dry place out of direct sunlight.
2. The battery self-discharges while it is stored. Recharge it once every three months in hot seasons and once every six months in cold seasons.

■ Cleaning Air Cleaner Primary Element

NOTE :

- If the air conditioner condenser is pulled out when cleaning the air cleaner, the air cleaner cover can be detached and attached easily. (See "Cleaning Radiator Screen" in "DAILY CHECK" in "PERIODIC SERVICE" section.)

1. Remove the air cleaner cover and primary element.
2. Clean the primary element:
 - (1) When dry dust adheres to the element, blow compressed air from the inside, turning the element. Pressure of compressed air must be under 205 kPa (2.1 kgf/cm², 30 psi).
 - (2) When carbon or oil adheres to the element, soak the element in detergent for 15 minutes then wash it several times in water, rinse with clean water and dry it naturally. After element is fully dried, inspect inside of the element with a light and check if it is damaged or not.
3. Replace air cleaner primary element:
Once yearly or after every sixth cleaning, whichever comes first.

NOTE :

- Check to see if the evacuator valve is blocked with dust.

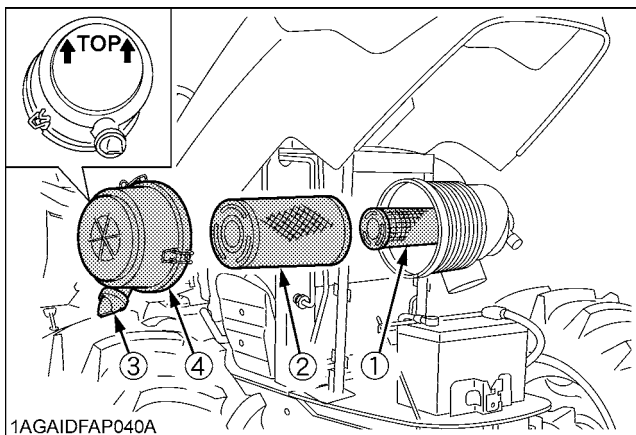

- (1) Secondary (safety) element
- (2) Primary element
- (3) Evacuator valve
- (4) Cover

IMPORTANT :

- The air cleaner uses a dry element, never apply oil.
- Do not run the engine with filter element removed.
- Be sure to refit the cover with the arrow ↑ (on the rear of cover) upright. If the cover is improperly fitted, evacuator valve will not function and dust will adhere to the element.
- Do not touch the secondary element except in cases where replacing is required. (See "Replacing Air Cleaner Secondary Element" in "EVERY 1 YEAR" in "PERIODIC SERVICE" section.)

◆ Evacuator Valve

Open the evacuator valve once a week under ordinary conditions - or daily when used in a dusty place - to get rid of large particles of dust and dirt.

■ Adjusting Fan Belt Tension



CAUTION

To avoid personal injury:

- Be sure to stop the engine before checking belt tension.

Proper fan belt tension	A deflection of between 10 to 12 mm (0.39 to 0.47 in.) when the belt is pressed in the middle of the span.
-------------------------	--

1. Stop the engine and remove the key.
2. Apply moderate thumb pressure to belt between pulleys.
3. If tension is incorrect, loosen the alternator mounting bolts and, using a lever placed between the alternator and the engine block, pull the alternator out until the deflection of the belt falls within acceptable limits.
4. Replace fan belt if it is damaged.

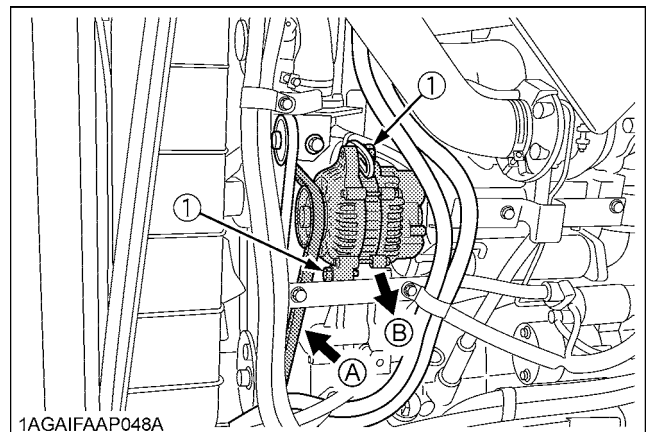

(1) Bolt

(A) Check the belt tension

(B) To tighten

■ Adjusting Clutch Pedal
 [Synchro shuttle model]

Proper clutch pedal free travel	40 to 50 mm (1.6 to 2.0 in.) on the pedal
---------------------------------	---

◆ **Adjusting procedure**

1. Stop the engine and remove the key.
2. Slightly depress the clutch pedal and measure free travel at the top of pedal stroke.
3. If adjustment is needed, loosen the lock nut and turn the nut to adjust the cable length within acceptable limits.
4. Retighten the lock nut.

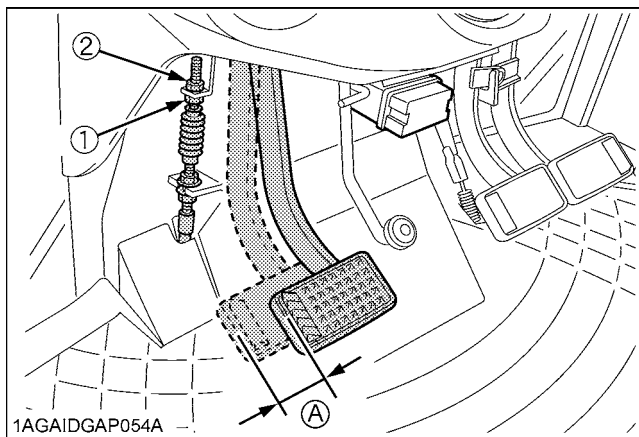

(1) Lock nut
 (2) Nut
 (A) Free travel

■ Adjusting Brake Pedal

⚠ CAUTION

To avoid personal injury:

- Stop the engine and chock the wheels before checking brake pedal.
- To prevent uneven braking, the specification must be within the recommended limit. If found out of the specifications, contact your local KUBOTA Dealer for adjusting the brakes.

◆ **Checking the brake pedal free travel**

Proper brake pedal free travel	7 to 14 mm (0.3 to 0.6 in.) on the pedal
	Keep the free travel in the right and left brake pedals equal.

1. Set the parking brake.
2. Slightly depress the brake pedals and measure free travel at the top of pedal stroke.

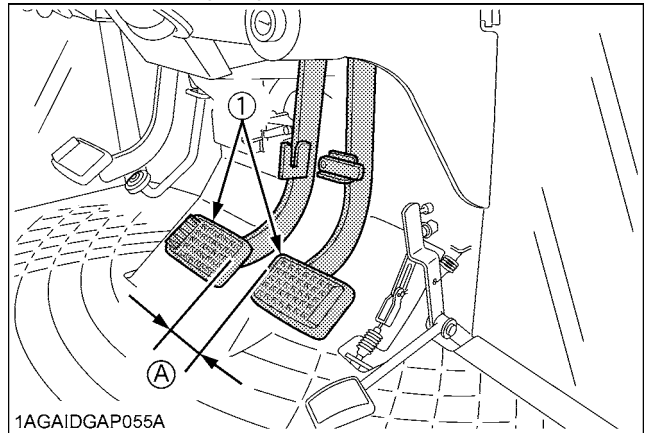

(1) Brake pedals
 (A) "FREE TRAVEL"

NOTE :

- Brake pedals should be equal when depressed.

◆ **Checking the brake pedal stroke**

Pedal stroke	Less than 100 mm (3.9 in.) at each pedal
--------------	--

1. Disengage the brake pedal lock.
2. Depress the brake pedal several times.
3. Step on the right-hand pedal and measure the level difference (pedal stroke) between this pedal and the left-hand pedal.
4. Do the same for the left-hand pedal.

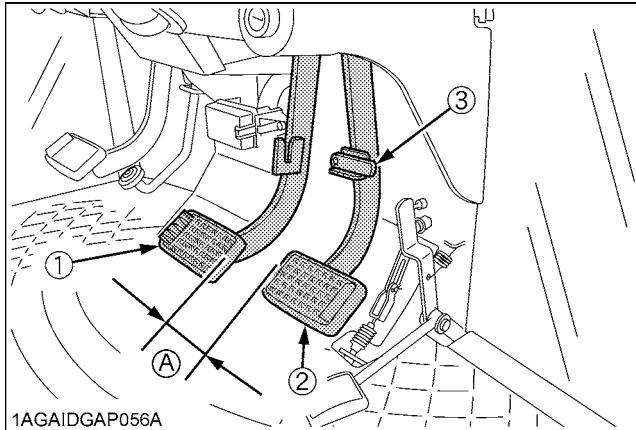

(1) Brake pedal (LH) (A) "PEDAL STROKE"
 (2) Brake pedal (RH)
 (3) Brake pedal lock

◆ **Checking the equalizer working level (anti-imbalance device)**

1. Gently step on both brake pedals at once.
2. Further step on the right-hand pedal (the left-hand pedal slightly raises itself) and measure the level difference between the pedals.
3. Do the same for the left-hand pedal.

Equalizer working level	Level difference of over 5 mm (0.2 in.) between both pedals
-------------------------	---

■ **Checking Parking Brake Lever**



CAUTION

To avoid personal injury:

- Do not dismounting the tractor while checking the parking brake.

Confirm the tractor (tractor unit only) can surely be parked on the slope of about 15 degrees (Slope that rises by 2.7 meters every 10 meters).

If the tractor moves, consult your local KUBOTA Dealer. Always engage the parking brake before dismounting the tractor.

■ **Checking Fuel Line**

1. Check to see that all lines and hose clamps are tight and not damaged.
2. If hoses and clamps are found worn or damaged, replace or repair them at once.

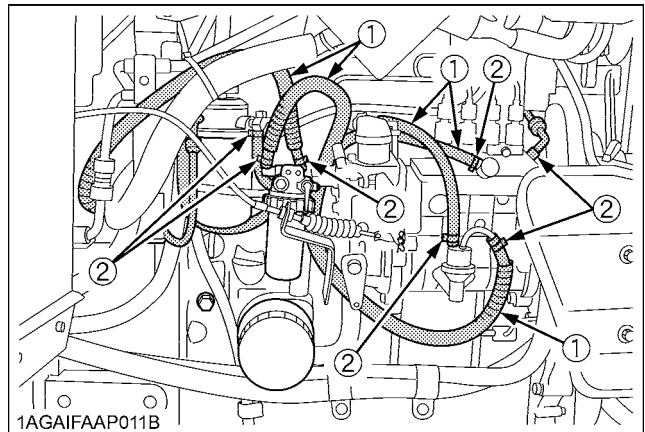

(1) Fuel lines
 (2) Clamp bands

NOTE :

- If the fuel line is removed, be sure to properly bleed the fuel system. (See "Bleeding Fuel System" in "SERVICE AS REQUIRED" in "PERIODIC SERVICE" section.)

■ Lubricating Grease Fittings

Apply a small amount of multipurpose grease to the following points every 100 hours:

If you operated the machine in extremely wet and muddy conditions, lubricate grease fittings more often.

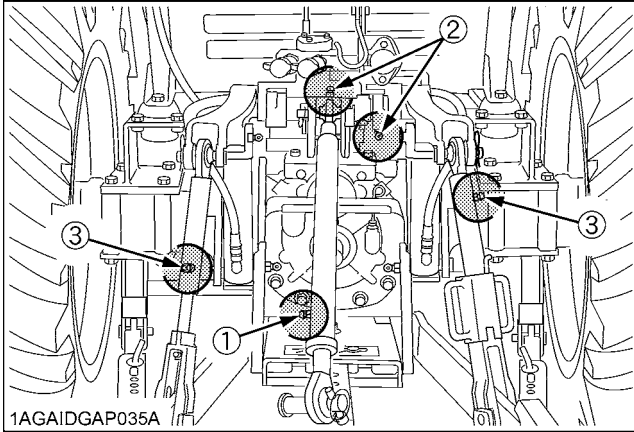

- (1) Grease fitting (Top link)
- (2) Grease fitting (Top link bracket)
- (3) Grease fitting (Lifting rod)

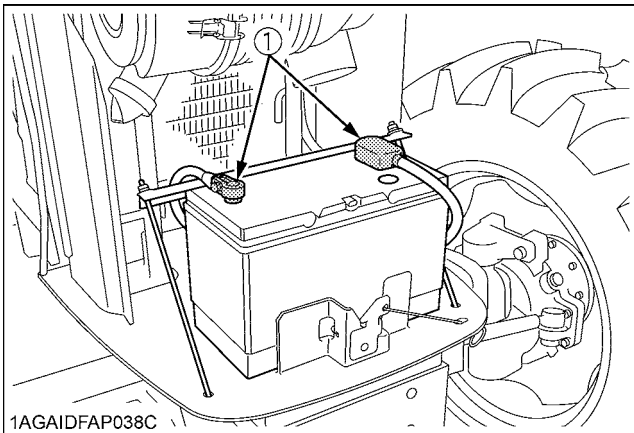

- (1) Battery terminals

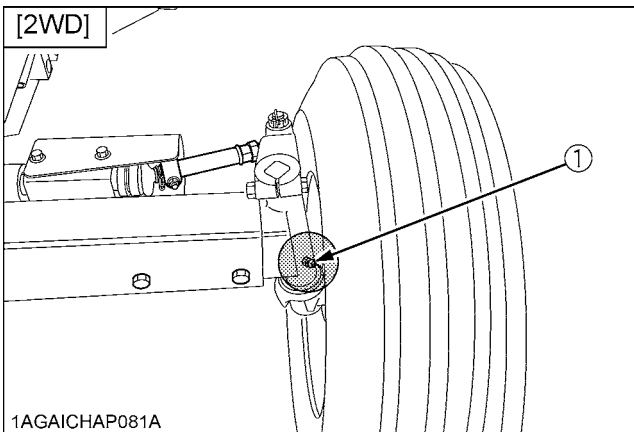

- (1) Grease fitting (Knuckle shaft) [RH, LH]

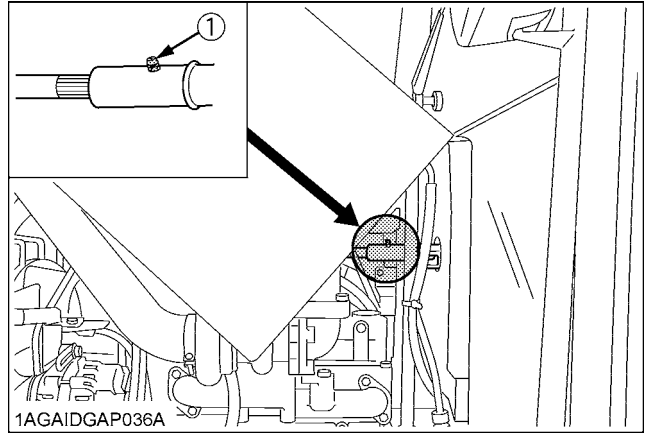

- (1) Grease fitting (Steering joint shaft)

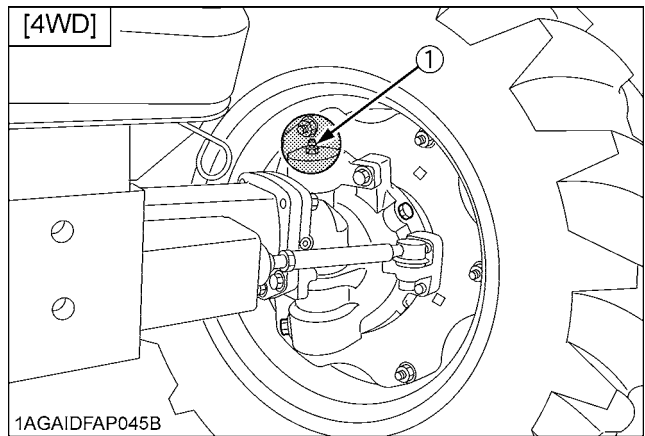

- (1) Grease fitting (Front axle gear case support) [RH, LH]

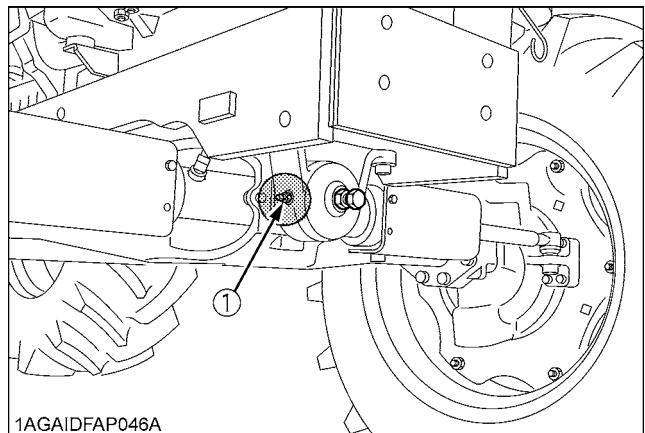

- (1) Grease fitting (Front axle support)

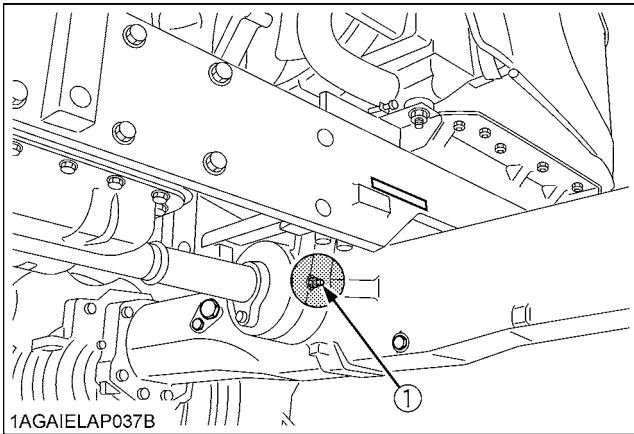

(1) Grease fitting (Front axle support)

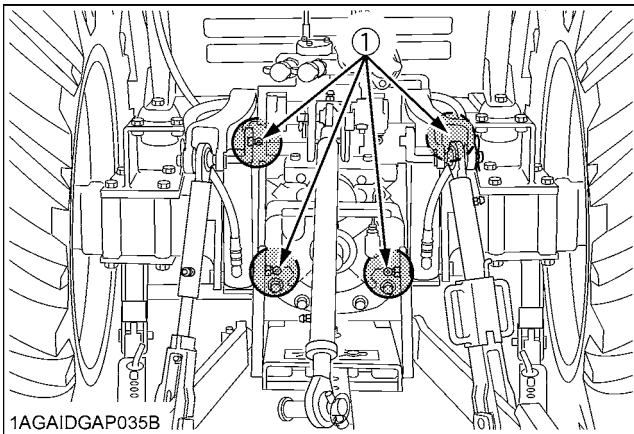

(1) Grease fitting (Hydraulic lift cylinders pin)

EVERY 200 HOURS

■ Checking Radiator Hose and Clamp

Check to see if radiator hoses are properly fixed every 200 hours of operation or six months, whichever comes first.

1. If hose clamps are loose or water leaks, tighten bands securely.
2. Replace hoses and tighten hose clamps securely, if radiator hoses are swollen, hardened or cracked.

Replace hoses and hose clamps every 2 years or earlier if checked and found that hoses are swollen, hardened or cracked.

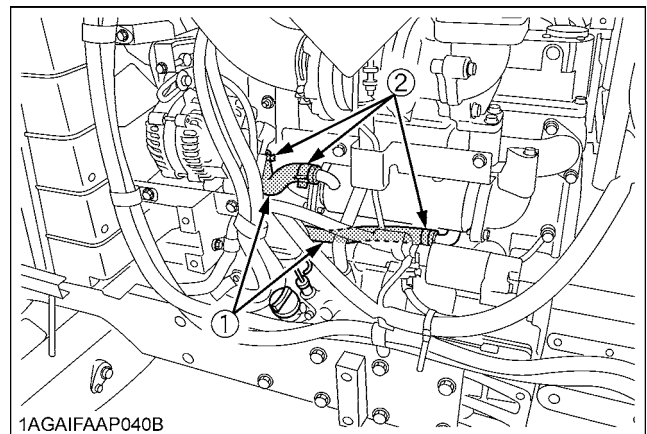
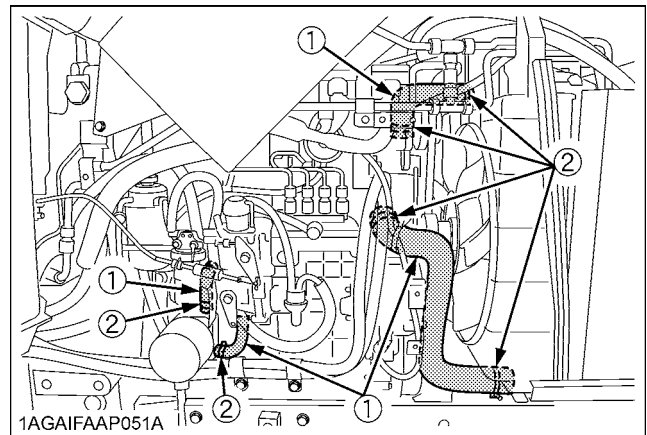

- (1) Radiator hoses
- (2) Hose clamps

◆ Precaution at Overheating

Take the following actions in the event the coolant temperature is nearly or more than the boiling point, what is called "Overheating"

1. Park the tractor in a safe place and keep the engine unloaded idling.
2. Don't stop the engine suddenly, but stop it after about 5 minutes of unloaded idling.
3. Keep yourself well away from the machine for further 10 minutes or while the steam blows out.

4. Check that there are no dangers such as burns. Get rid of the causes of overheating according to the manual, see "TROUBLESHOOTING" section, and then, start again the engine.

■Checking Intake Air Line

1. Check to see that hoses and hose clamps are tight and not damaged.
2. If hoses and clamps are found worn or damaged, replace or repair them at once.

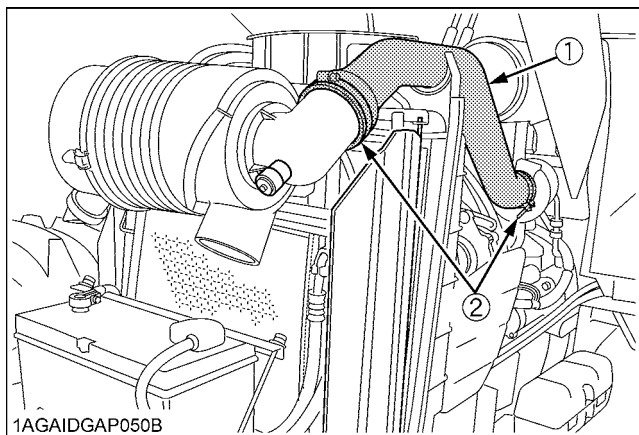

- (1) Hose
(2) Hose clamps

■Checking Power Steering Line

1. Check to see that all lines and hose clamps are tight and not damaged.
2. If hoses and clamps are found worn or damaged, replace or repair them at once.

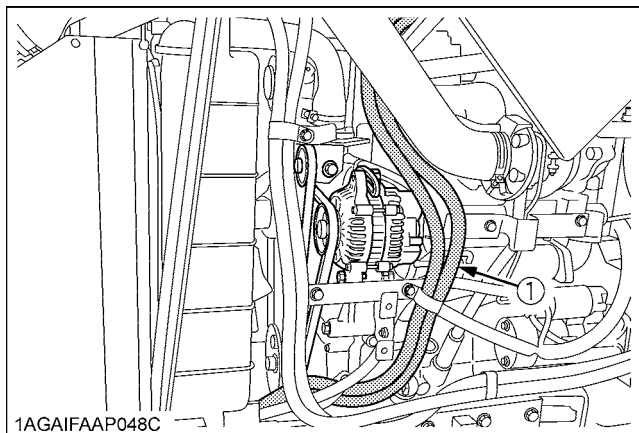

- (1) Power steering pressure hoses

■Adjusting Toe-in

	Proper toe-in
4WD	2 to 8 mm (0.08 to 0.31 in.)
2WD	1 to 5 mm (0.04 to 0.2 in.)

1. Park tractor on a flat place.
2. Turn steering wheel so front wheels are in the straight ahead position.
3. Lower the implement, lock the park brake and stop the engine.
4. Measure distance between tire beads at front of tire, at hub height.
5. Measure distance between tire beads at rear of tire, at hub height.
6. Front distance should be shorter than rear distance. If not, adjust tie rod length.

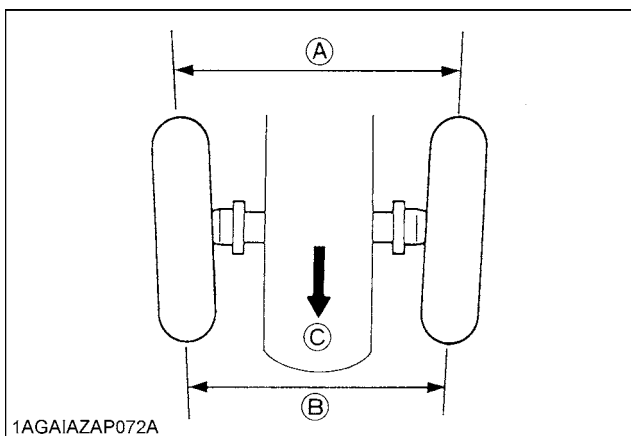

- (A) Wheel - to - wheel distance at rear
(B) Wheel - to - wheel distance at front
(C) "FRONT"

◆ **Adjusting procedures**

1. Detach the snap ring.
2. Loosen the tie-rod nut.
3. Turn the tie-rod joint to adjust the rod length until the proper toe-in measurement is obtained.
4. Retighten the tie-rod nut.
5. Attach the snap ring of the tie-rod joint.

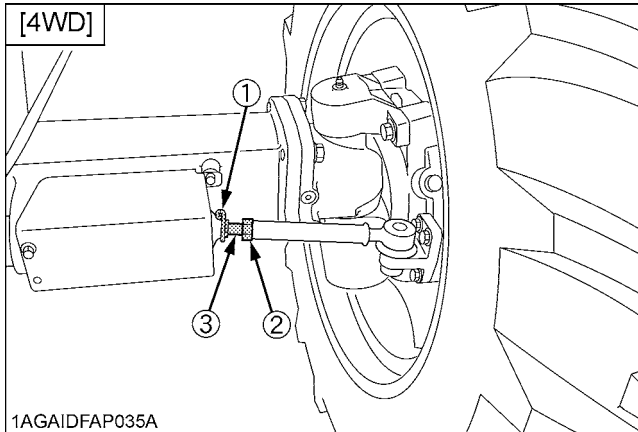

- (1) Snap ring
- (2) Tie-rod nut
(167 to 196 N-m, 17 to 20 kgf-m, 123.2 to 144.6 ft-lbs)
- (3) Tie-rod joint

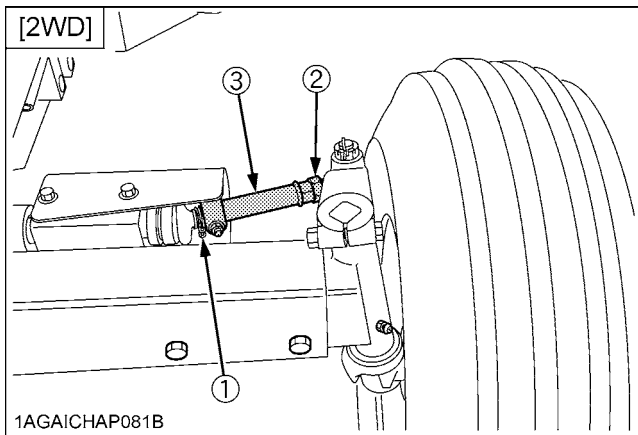

- (1) Snap ring
- (2) Tie-rod nut
(167 to 196 N-m, 17 to 20 kgf-m, 123.2 to 144.6 ft-lbs)
- (3) Tie-rod joint

■ **Draining Fuel Tank Water**

Loosen the drain plug at the bottom of the fuel tank to let sediments, impurities and water out of the tank. Finally tighten up the plug.

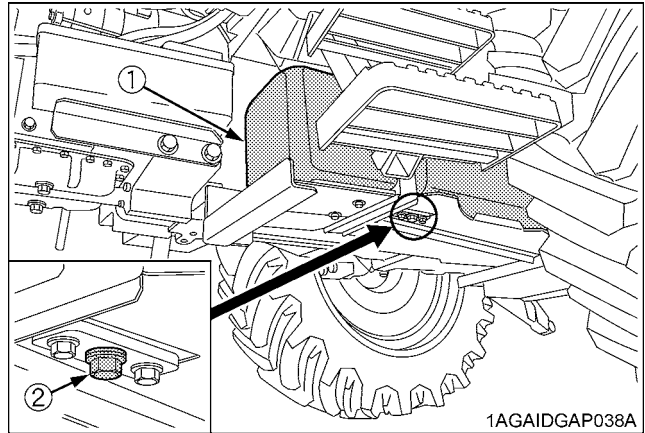

- (1) Fuel Tank (Left)
- (2) Drain plug

IMPORTANT :

- If the fuel contains poor qualities with much water in it, drain the fuel tank at shorter intervals.
- Drain the fuel tank before operating the tractor after a long period of storage.
- The fuel tank is made of plastic. Be careful not to overtighten the bolts.

■ **Cleaning Inner Air Filter**

Remove the knob bolts and pull out filter. Blow air from the direction opposite to the filter's normal air flow. Pressure of compressed air must be under 205 kPa (2.1 kgf/cm², 30 psi).

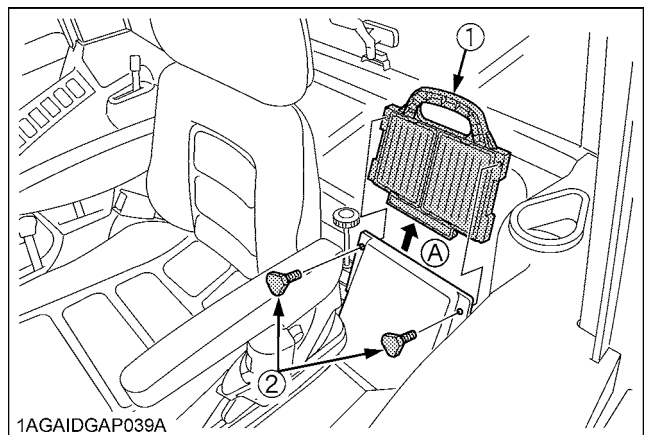

- (1) Inner air filter
 - (2) Knob bolts
- (A) "PULL OUT"

■ Cleaning Fresh Air Filter

Remove the knob bolts and pull out filter.

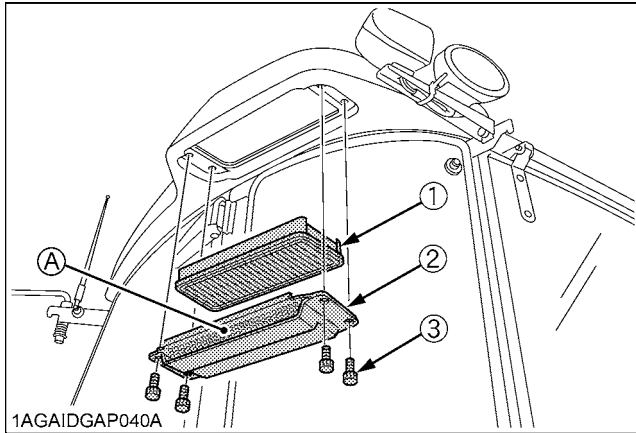

(1) Fresh air filter (A) Air inlet port
 (2) Cover
 (3) Knob bolt

NOTE :

- Attach the filter and cover as the illustration above.

◆ Cleaning the air filter

- Normal use
 Blow air from the opposite direction to the filter's normal air flow.
 Pressure of compressed air must be under 205 kPa (2.1 kg/cm², 30 psi).

IMPORTANT :

- Do not hit the filter. If the filter becomes deformed, dust may enter into the air-conditioner, which may cause damage and malfunction.

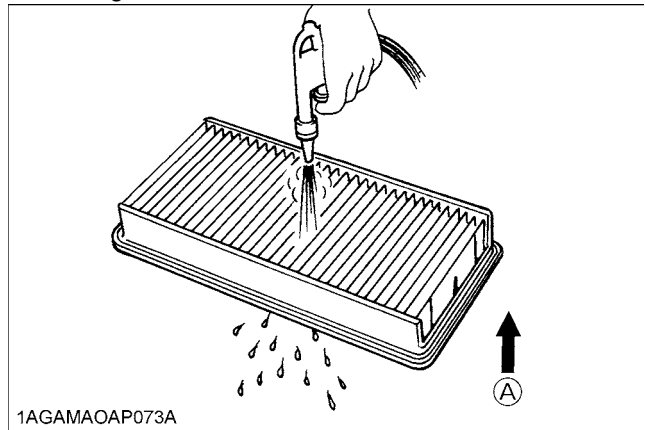

(A) "AIR CONDITIONER AIRFLOW"

NOTE :

- If the filter is very dirty:
 Dip the filter in lukewarm water with mild dish washing detergent.
 Move it up and down as well as left and right to loosen dirt. Rinse the filter with clean water and let it air-dry.

IMPORTANT :

- Do not use gasoline, thinner or similar chemicals to clean the filter as damage to the filter may occur.
- It may also cause an unpleasant odor in the CAB when the system is used next.

■ Checking Air Conditioner Condenser

Check air conditioner condenser to be sure it is clean of debris.

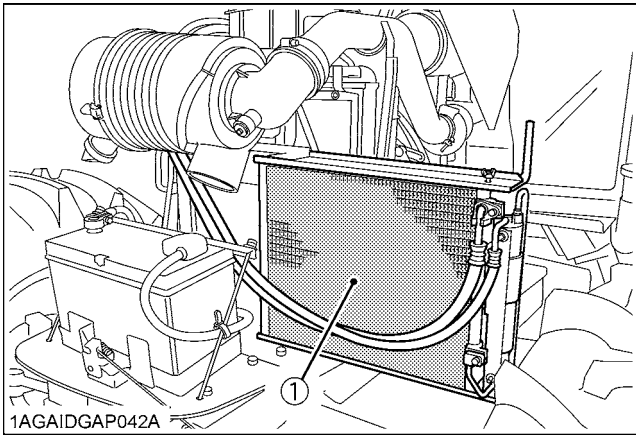

(1) Air conditioner condenser

◆ Sliding the air conditioner condenser



CAUTION

To avoid personal injury:

- Be sure to stop the engine before removing the screen.
- The condenser and receiver become hot while the air conditioner is running. Before checking or cleaning them, wait long enough until they cool down.

1. Loosen the wing nut.
2. Hold the handle, slide the air conditioner condenser assembly toward yourself.

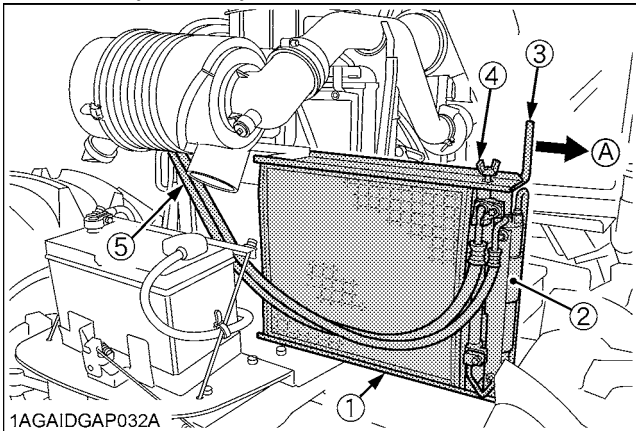

(1) Condenser (4) Wing nut (A) "PULL"
 (2) Receiver (5) Air conditioner hose
 (3) Handle

IMPORTANT :

- Do not hold the air conditioner receiver or the air conditioner pipes when sliding out the condenser for cleaning.

■ Adjusting Air-Conditioner Belt Tension

1. Push on the belt between the pulleys with a finger. A deflection of 10 to 12 mm (0.4 to 0.48 in.) under a 98N (10 kgf, 22 lbs.) load is appropriate.
2. If tension is incorrect, loosen the tension pulley mounting nut and turn the adjusting bolt to adjust the belt tension within acceptable limits.

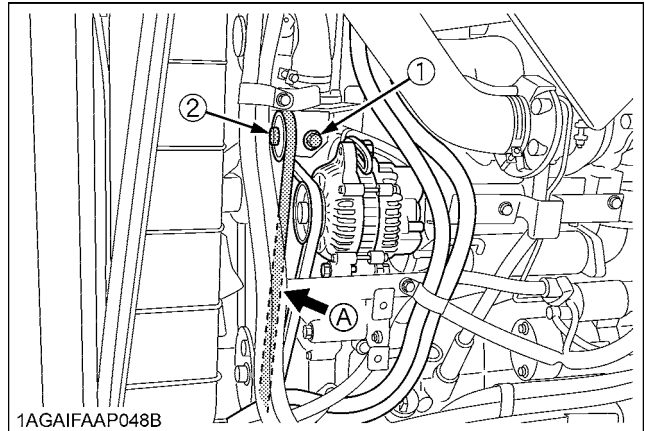

(1) Adjusting bolt (A) 10 to 12 mm
 (2) Tension pulley mounting nut (0.4 to 0.48 in.)

EVERY 300 HOURS

■ Replacing Hydraulic Oil Filter

◆ Cleaning Magnetic Filter



CAUTION

To avoid personal injury:

- Be sure to stop the engine before changing the oil filter cartridge.
- Allow engine to cool down sufficiently, oil can be hot and can burn.

1. Remove the drain plug at the bottom of the transmission case and drain the oil completely into an oil pan.
2. After draining reinstall the drain plug.

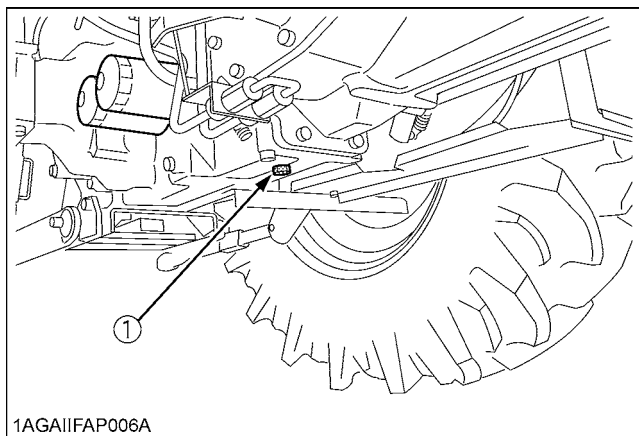

(1) Drain plug

3. Remove the two oil filters.
4. Wipe off metal filings from the magnetic filter with a clean rag.

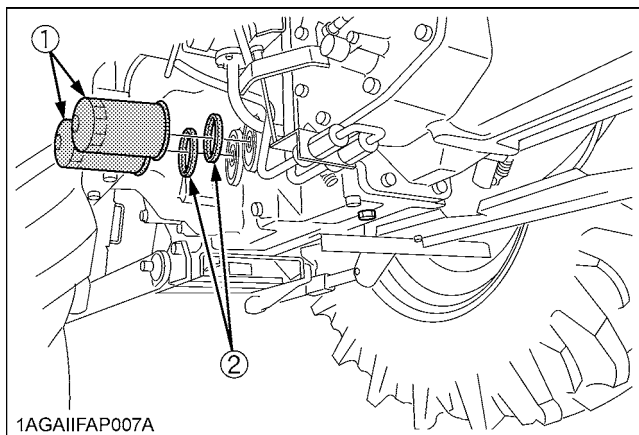

(1) Hydraulic oil filter

(2) Magnetic filter (Wipe off metal filings)

5. Put a film of clean transmission oil on the rubber seal of the new filters.

6. Tighten the filter quickly until it contacts the mounting surface.
Tighten filter by hand an additional 1/2 turn only.
7. After the new filters have been replaced, fill the transmission oil up to the upper notch on the dipstick.

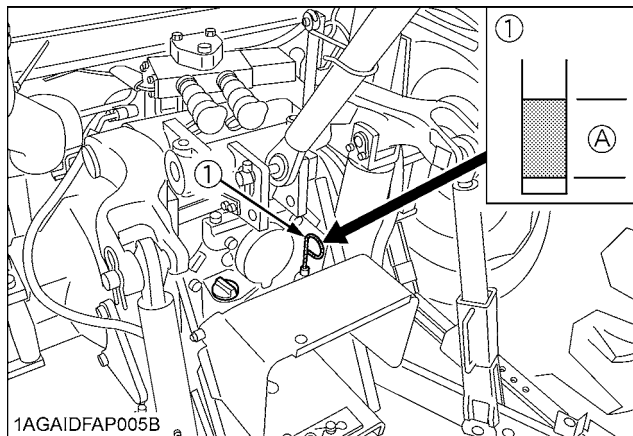

(1) Gauge

(A) Oil level is acceptable within this range.

8. After running the engine for a few minutes, stop the engine and check the oil level again, add oil to the prescribed level.
9. Make sure that the transmission fluid doesn't leak pass the seal on the filters.

IMPORTANT :

- To prevent serious damage to the hydraulic system, use only a KUBOTA genuine filter.
- Do not operate the tractor immediately after changing the transmission fluid.
Run the engine at medium speed for a few minutes to prevent damage to the transmission.

■ Changing Engine Oil

CAUTION

To avoid personal injury:

- Be sure to stop the engine before changing the oil.
- Allow engine to cool down sufficiently, oil can be hot and can burn.

1. To drain the used oil, remove the drain plug at the bottom of the engine and drain the oil completely into the oil pan.
All the used oil can be drained out easily when the engine is still warm.
2. After draining reinstall the drain plug.
3. Fill with the new oil up to the upper notch on the dipstick.
(See "LUBRICANTS" in "MAINTENANCE" section.)

Oil capacity with filter	10.7 L (11.3 U.S.qts.)
--------------------------	------------------------

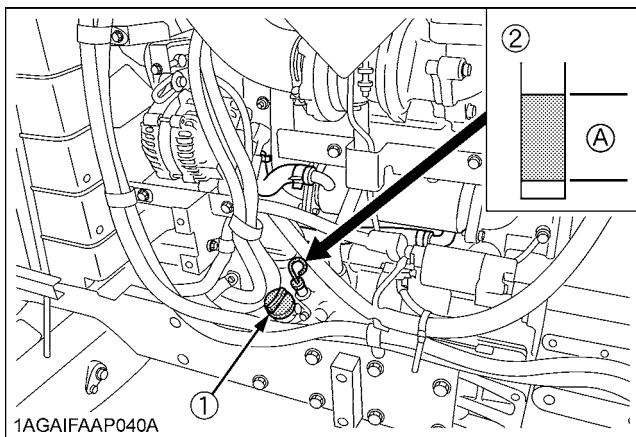

(1) Oil inlet (A) Oil level is acceptable within this range
(2) Dipstick

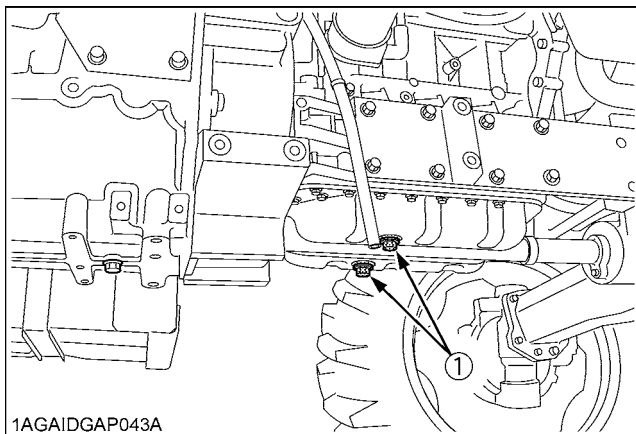

(1) Drain plug

EVERY 400 HOURS

■ Replacing Fuel Filter

1. Remove the fuel filter.
2. Put a film of clean fuel on rubber seal of new filter.
3. Tighten the filter quickly until it contacts the mounting surface.
Tighten filter by hand an additional 1/2 turn only.
4. Bleed the fuel system.
(See "Bleeding Fuel System" in as required maintenance)

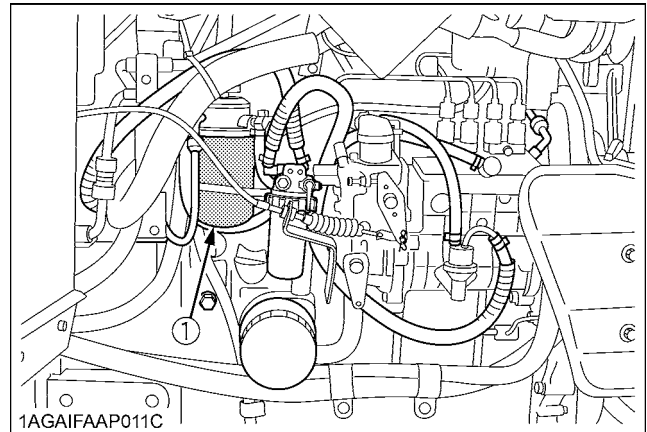

(1) Fuel filter

■Cleaning Water Separator

This job should not be done in the field, but in a clean place.

1. Close the fuel cock.
2. Unscrew the retainer ring and remove the cup, and rinse the inside with kerosene.
3. Take out the element and dip it in the kerosene to rinse.
4. After cleaning, reassemble the water separator, keeping out dust and dirt.
5. Bleed the fuel system.
(See "Bleeding Fuel System" in "SERVICE AS REQUIRED" in "PERIODIC SERVICE" section.)

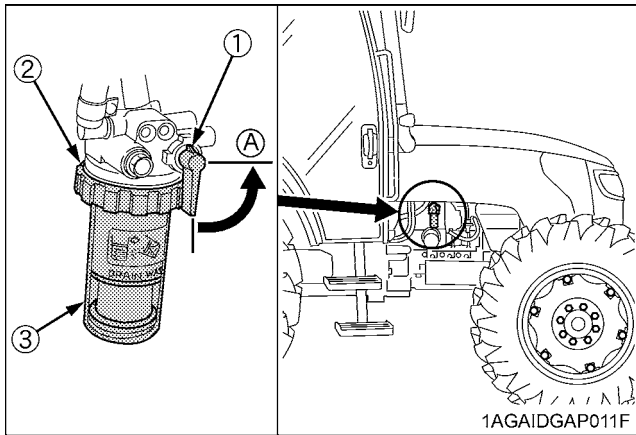

- (1) Fuel cock
- (2) Retainer ring
- (3) Cup

(A) "CLOSE"

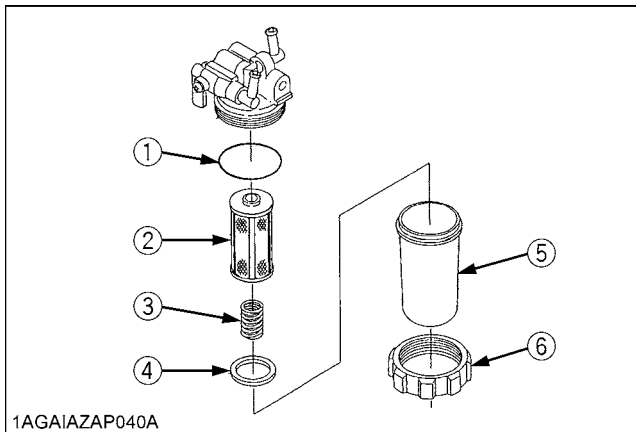

- (1) O ring
- (2) Element
- (3) Spring
- (4) Red float
- (5) Cup
- (6) Retainer ring

■Lubricating Grease Fitting [2WD Model]

Detach the cover, and apply bearing grease.

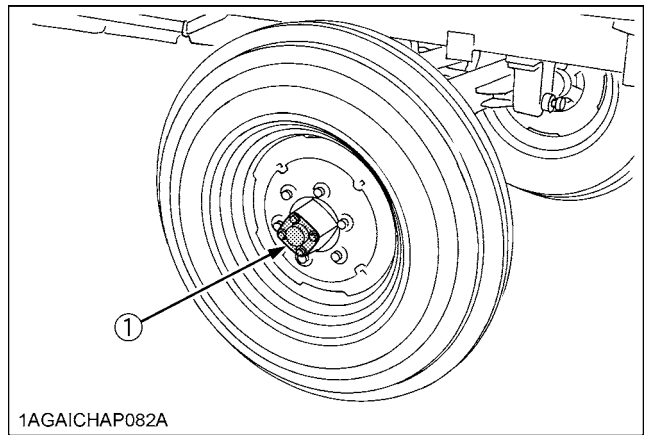

(1) Front wheel hub cover

EVERY 600 HOURS

■ Replacing Engine Oil Filter



CAUTION

To avoid personal injury:

- Be sure to stop the engine before changing the oil filter cartridge.
- Allow engine to cool down sufficiently, oil can be hot and can burn.

1. Remove the oil filter.
2. Put a film of clean engine oil on the rubber seal of the new filter.
3. Tighten the filter quickly until it contacts the mounting surface.
Tighten filter by hand an additional 1/2 turn only.
4. After the new filter has been replaced, the engine oil normally decreases a little. Make sure that the engine oil does not leak through the seal and be sure to check the oil level on the dipstick. Then, replenish the engine oil up to the prescribed level.

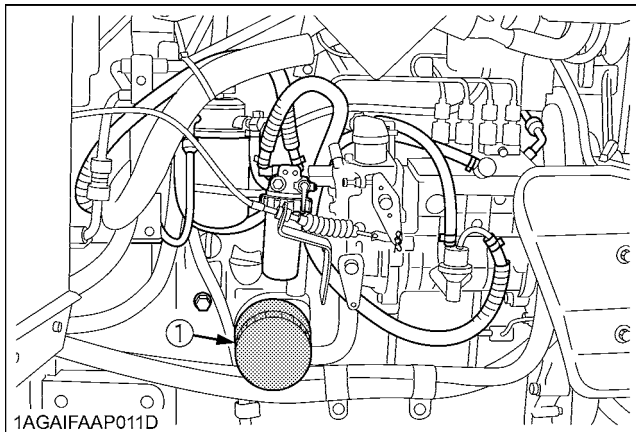

1AGAIFAAP011D

(1) Engine oil filter

IMPORTANT :

- To prevent serious damage to the engine, use only a KUBOTA genuine filter.

■ Changing Transmission Fluid



CAUTION

To avoid personal injury:

- Allow engine to cool down sufficiently, oil can be hot and can burn.

1. To drain the used oil, remove the drain plug at the bottom of the transmission case and drain the oil completely into the oil pan
2. After draining reinstall the drain plug.

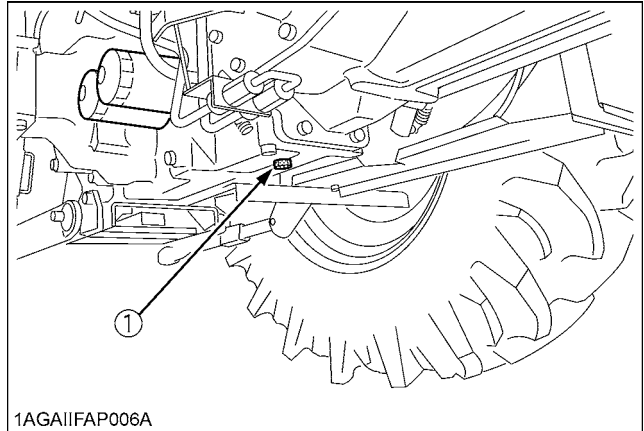

1AGAIFAP006A

(1) Drain plug

3. Remove the two oil filters.
4. Wipe off metal filings from the magnetic filter with a clean rag.

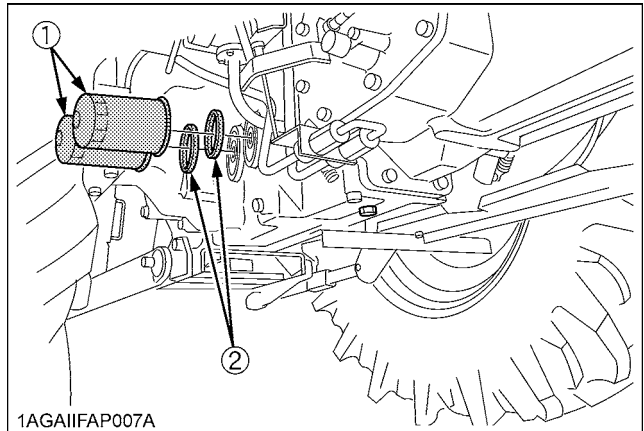

1AGAIFAP007A

(1) Hydraulic oil filter
(2) Magnetic filter (wipe metal filings)

5. Put a film of clean transmission oil on rubber seal of new filters.
6. Tighten the filter quickly until it contacts the mounting surface.
Tighten filter by hand an additional 1/2 turn only.

7. Fill with the new KUBOTA SUPER UDT fluid up to the upper notch on the dipstick.
(See "LUBRICANTS" in "MAINTENANCE" section.)
8. After running the engine for a few minutes, stop the engine and check the oil level again; add oil to prescribed level.
9. Make sure that the transmission fluid doesn't leak past the seal on the filters.

Oil capacity	60 L (63.4 U.S.qts.)
--------------	----------------------

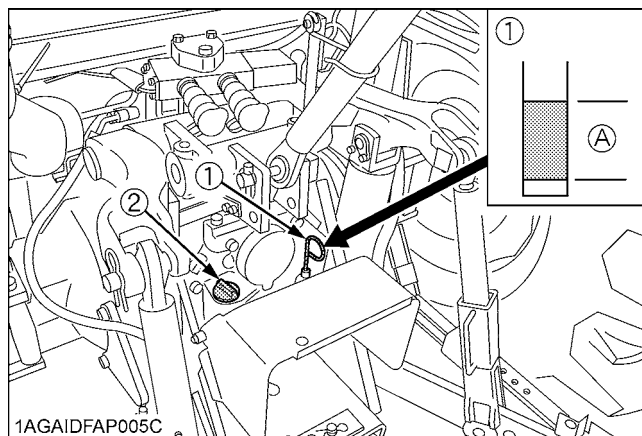

(1) Gauge (A) Oil level is acceptable within this range
(2) Oil inlet

IMPORTANT :

- To prevent serious damage to the hydraulic system, use only a KUBOTA genuine filter.
- Do not operate the tractor immediately after changing the transmission fluid.
Run the engine at medium speed for a few minutes to prevent damage to the transmission.

Changing Front Differential Case Oil

1. To drain the used oil, remove the drain and filling plug at the front differential case and drain the oil completely into the oil pan.
2. After draining reinstall the drain plug.
3. Remove the oil level check plug.
4. Fill with the new oil up to the lower rim of check plug port.
(See "LUBRICANTS" in "MAINTENANCE" section.)
5. After filling reinstall the filling plug and check plug.

Oil capacity	6 L (6.3 U.S.qts.)
--------------	--------------------

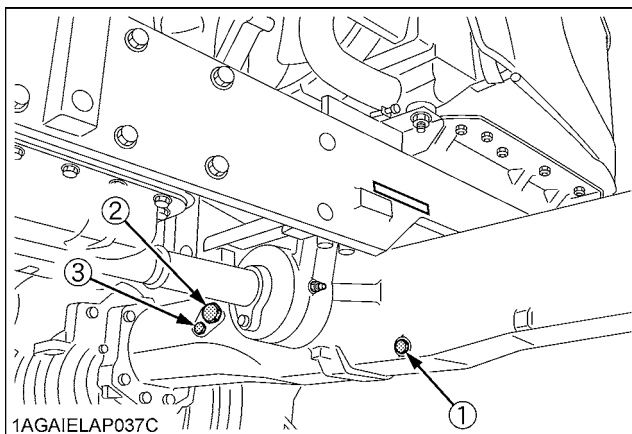

(1) Drain plug
(2) Filling plug
(3) Check plug

■ Changing Front Axle Gear Case Oil

1. To drain the used oil, remove the right and left drain plugs and filling plugs at the front axle gear case and drain the oil completely into the oil pan.
2. After draining reinstall the drain plugs.
3. Fill with the new oil up to the filling plug port.
(See "LUBRICANTS" in "MAINTENANCE" section.)
4. After filling reinstall the filling plugs.

Oil capacity	3.5 L (3.7 U.S.qts.) for each side
--------------	------------------------------------

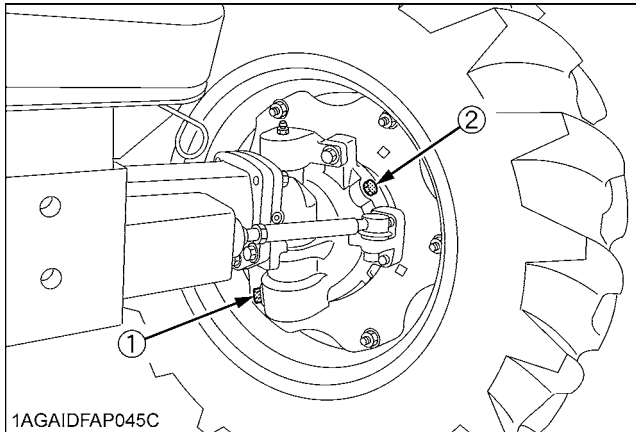

- (1) Drain plug
- (2) Filling plug

■ Adjusting Front Axle Pivot

If the front axle pivot pin adjustment is not correct, front wheel vibration can occur causing vibration in the steering wheel.

◆ Adjusting procedure

Loosen the lock nut, screw-in the adjusting screw until seated, then tighten the screw with an additional 1/6 turn. Re-tighten the lock nut.

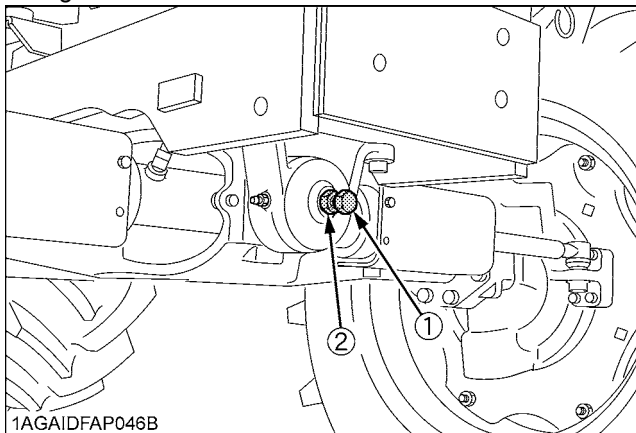

- (1) Adjusting screw
- (2) Lock nut

EVERY 800 HOURS

■ Adjusting Engine Valve Clearance

Consult your local KUBOTA Dealer for this service.

EVERY 1500 HOURS

■ Checking Fuel Injection Nozzle (Injection Pressure)

Consult your local KUBOTA Dealer for this service.

EVERY 3000 HOURS

■ Checking Turbocharger

■ Checking Injection Pump

■ Checking Intake Air Heater

Consult your local KUBOTA Dealer for this service.

EVERY 1 YEAR

■ Replacing Air Cleaner Primary Element and Secondary Element

(See "Cleaning Air Cleaner Primary Element" in "EVERY 100 HOURS" in "PERIODIC SERVICE" section.)

■ Checking Air-Conditioner Pipe and Hose

1. Check to see that all lines and hose clamps are tight and not damaged.
2. If hoses and clamps are found worn or damaged, consult your local KUBOTA Dealer for this service.

■ Checking CAB Isolation Cushion

Check the cushion for any breakage or fatigue. Replace them if they are deteriorated.

EVERY 2 YEARS

■ Flushing Cooling System and Changing Coolant



CAUTION

To avoid personal injury:

- Do not remove radiator cap while coolant is hot. When cool, slowly rotate cap to the first stop and allow sufficient time for excess pressure to escape before removing the cap completely.

1. Stop the engine, remove the key and let it cool down.
2. To drain the coolant, open the radiator drain plug, remove the drain plug and remove radiator cap. The radiator cap must be removed to completely drain the coolant.
3. After all coolant is drained, reinstall the drain plug.
4. Fill with clean soft water and cooling system cleaner.
5. Follow directions of the cleaner instruction.
6. After flushing, fill with clean soft water and anti-freeze until the coolant level is just below the radiator cap. Install the radiator cap securely.
7. Fill with coolant up to the "FULL" mark of recovery tank.
8. Start and operate the engine for few minutes.
9. Stop the engine, remove the key and let cool.
10. Check coolant level of recovery tank and add coolant if necessary.
11. Properly dispose of used coolant.

Coolant capacity	9 L (9.5 U.S.qts.)
------------------	--------------------

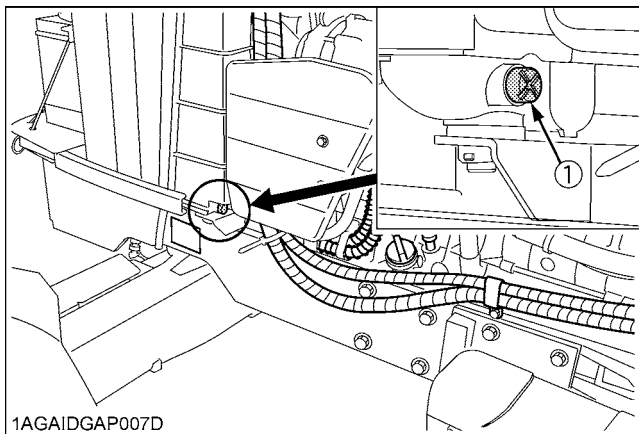

(1) Drain plug ((+) Plus screwdriver)

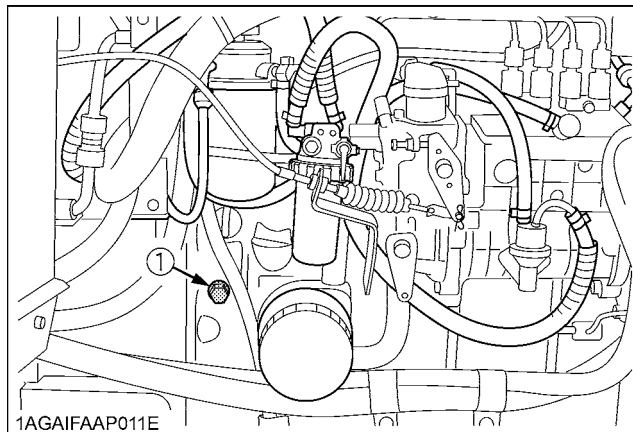

(1) Drain plug

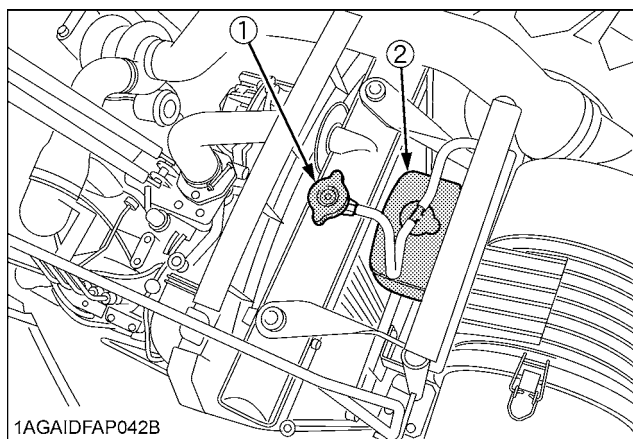

(1) Radiator cap
(2) Recovery tank

IMPORTANT :

- Do not start engine without coolant.
- Use clean, fresh soft water and anti-freeze to fill the radiator and recovery tank.
- When mixing the anti-freeze with water, the anti-freeze mixing ratio is 50 %.
- Securely tighten radiator cap. If the cap is loose or improperly fitted, water may leak out and the engine could overheat.

NOTE :

- On cab type machines, coolant circulates through the heater. This means that one more liter or so of coolant is required.

In changing coolant, pour coolant up to the filler port of the recovery tank. Turn ON the heater (shift the temperature control dial toward WARM), and run the engine for a while in order to warm coolant. Then stop the engine.

When coolant has cooled down, some of the coolant in the recovery tank is sucked. Now the recovery tank is appropriately filled with coolant.

■Anti-Freeze



To avoid personal injury:

- **When using antifreeze, put on some protection such as rubber gloves (Antifreeze contains poison.).**
- **If should drink antifreeze, throw up at once and take medical attention.**
- **When antifreeze comes in contact with the skin or clothing, wash it off immediately.**
- **Do not mix different types of Antifreeze. The mixture can produce chemical reaction causing harmful substances.**
- **Antifreeze is extremely flammable and explosive under certain conditions. Keep fire and children away from antifreeze.**
- **When draining fluids from the engine, place some container underneath the engine body.**
- **Do not pour waste onto the grounds, down a drain, or into any water source.**
- **Also, observe the relevant environmental protection regulations when disposing of antifreeze.**

If it freezes, coolant can damage the cylinders and radiator. If the ambient temperature falls below 0 °C (32 °F) or before a long-term storage, let out cooling water completely, or mix fresh water with long-life coolant and fill the radiator and recovery tank with the mixture.

1. Long-life coolant (hereafter LLC) comes in several types. Use ethylene glycol (EG) type for this engine.
2. Before employing LLC-mixed cooling water, fill the radiator with fresh water and empty it again. Repeat this procedure 2 or 3 times to clean up the inside.
3. Mixing the LLC
Put the LLC in cooling water in the percentage (%) for a target temperature. When mixing, stir it up well, and then fill into the radiator.
4. The procedure for the mixing of water and antifreeze differs according to the make of the antifreeze and the ambient temperature. Refer to SAE J1034 standard, more specifically also to SAE J814c.

IMPORTANT :

- When the antifreeze is mixed with water, the antifreeze mixing ratio must be less than 50%.

Vol % Anti-freeze	Freezing Point		Boiling Point*	
	°C	°F	°C	°F
40	-24	-12	106	222
50	-37	-34	108	226

* At 1.013 x 10⁵Pa (760mmHg) pressure (atmospheric). A higher boiling point is obtained by using a radiator pressure cap which permits the development of pressure within the cooling system.

5. Adding the LLC
 - (1) Add only water if the mixture reduces in amount by evaporation.
 - (2) If there is a mixture leak, add the LLC of the same manufacturer and type in the same mixture percentage.
 - * Never add any long-life coolant of different manufacturer. (Different brands may have different additive components, and the engine may fail to perform as specified.)
6. When the LLC is mixed, do not employ any radiator cleaning agent. The LLC contains anticorrosive agent. If mixed with the cleaning agent, sludge may build up, adversely affecting the engine parts.
7. Kubota's genuine long-life coolant has a service life of 2 years. Be sure to change the coolant every 2 years.

NOTE :

- The above data represent industry standards that necessitate a minimum glycol content in the concentrated antifreeze.
- When the coolant level drops due to evaporation, add water only to keep the antifreeze mixing ratio less than 50%. In case of leakage, add antifreeze and water in the specified mixing ratio before filling in to the radiator.

■ Replacing Radiator Hose (Water pipes)

Replace the hoses and clamps.
(See "Checking Radiator Hose and Clamp" in "EVERY 200 HOURS" in "PERIODIC SERVICE" section.)

■ Cleaning Master Cylinder Filter

Consult your local KUBOTA Dealer for this service.

■ Replacing Power Steering Hose

Consult your local KUBOTA Dealer for this service.

■ Replacing Fuel Hose

Consult your local KUBOTA Dealer for this service.

■ Replacing Intake Air Line

(See "Checking Intake Air Line" in "EVERY 200 HOURS" in "PERIODIC SERVICE" section.)

■ Replacing Lift Cylinder Hose

Consult your local KUBOTA Dealer for this service.

■ Replacing Master Cylinder Kit

Consult your local KUBOTA Dealer for this service.

■ Replacing Equalizer Kit

Consult your local KUBOTA Dealer for this service.

■ Replacing Brake Seal 1 and 2

Consult your local KUBOTA Dealer for this service.

■ Replacing Air Conditioner Hose

Consult your local KUBOTA Dealer for this service.

SERVICE AS REQUIRED

■ Bleeding Fuel System

Air must be removed:

1. When the fuel filter or lines are removed.
2. When water is drained from water separator.
3. When tank is completely empty.
4. After the tractor has not been used for a long period of time.

◆ Bleeding procedure is as follows:

1. Fill the fuel tank with fuel, and open the fuel cock.

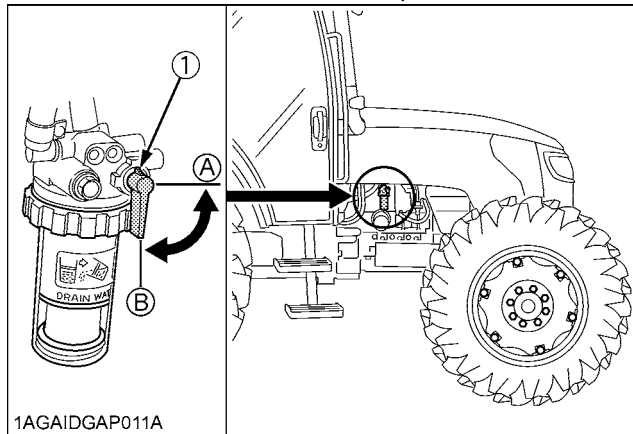

(1) Fuel cock

(A) "CLOSE"

(B) "OPEN"

2. Pump the fuel pump knob (1) located on the top of the fuel filter. The fuel pump knob will pump easily at first and with added resistance as air is purged from the system. To make sure air is completely purged, pinch the fuel overflow hose with fingers, if a pulsation is felt when the knob is pumped, then, no air remains.

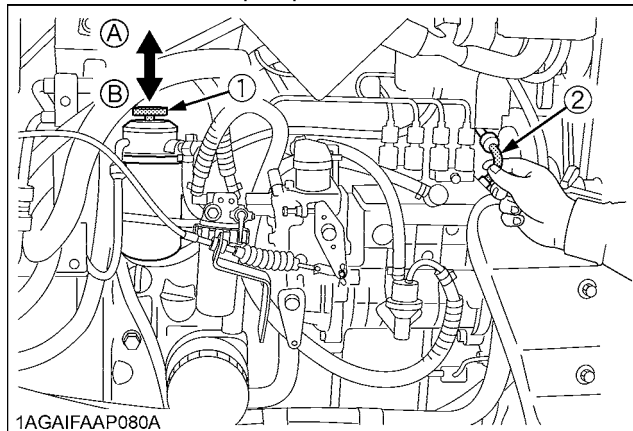

(1) Fuel pump knob

(A) "UP"

(2) Fuel overflow hose

(B) "DOWN"

3. Set the hand throttle lever at the maximum speed position, turn the key switch to start the engine and then reset the throttle lever at the mid speed (around 1500 rpm) position.
If engine doesn't start, try it several times at 30 second intervals.

IMPORTANT :

- Do not hold key switch at engine start position for more than 10 seconds continuously. If more engine cranking is needed, try again after 30 seconds.
4. Accelerate the engine to remove the small portion of air left in the fuel system.
 5. If air still remains and the engine stops, repeat the above steps.

■ Bleeding Brake System

Consult your local KUBOTA Dealer for this service.

■ Draining Clutch Housing Water

The tractor is equipped with a drain plug under the clutch housing. After operating in rain, snow or if the tractor has been washed, water may get into the clutch housing. Remove the drain plug and drain the water, then install the plug again.

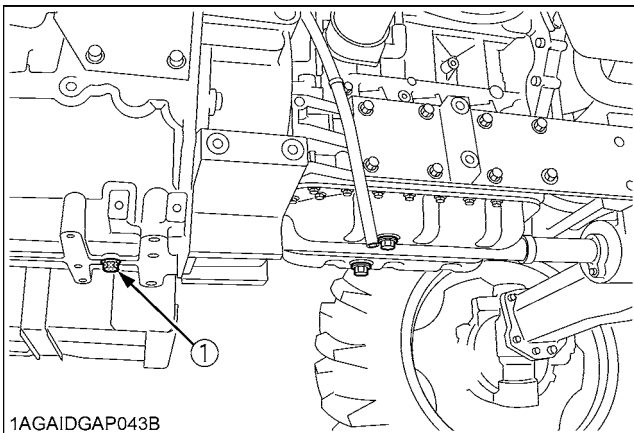

(1) Water drain plug

■ Replacing Fuse

The tractor electrical system is protected from potential damage by fuses. A blown fuse indicates that there is an overload or short somewhere in the electrical system. If any of the fuses should blow, replace with a new one of the same capacity.

IMPORTANT :

- Before replacing a blown fuse, determine why the fuse blew and make any necessary repairs. Failure to follow this procedure may result in serious damage to the tractor electrical system. Refer to the "TROUBLESHOOTING" section of this manual or your local KUBOTA Dealer for specific information dealing with electrical problems.

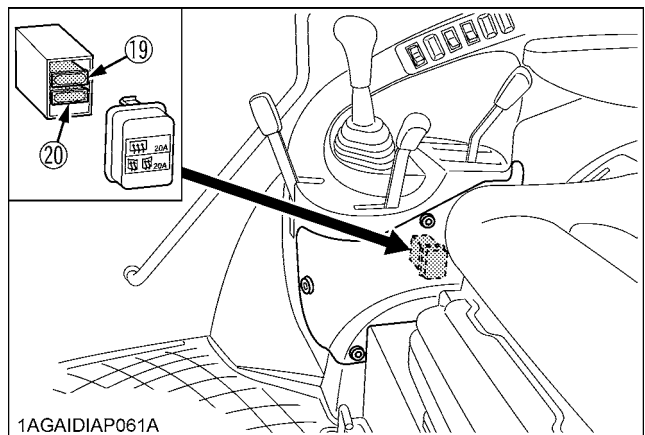
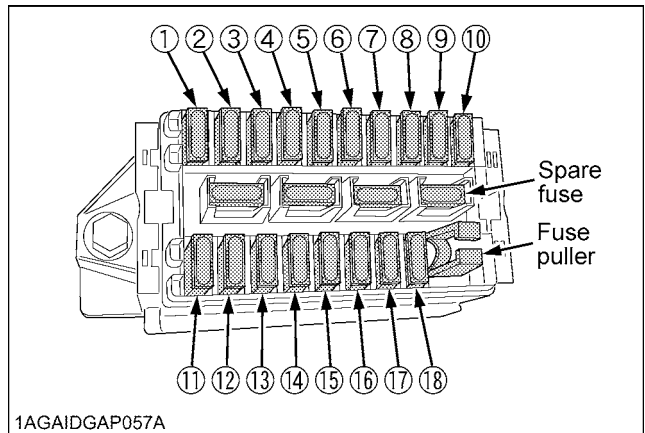
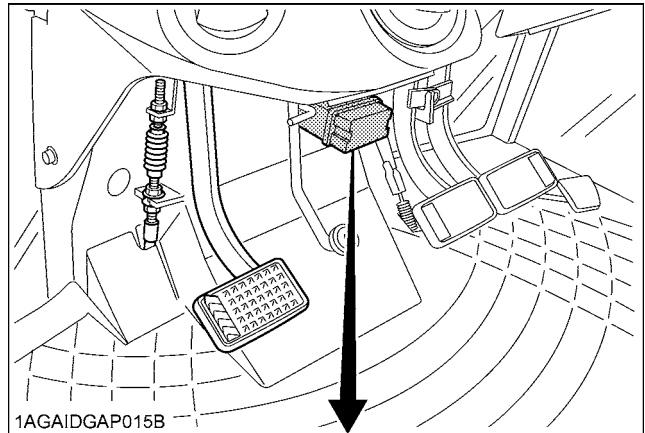

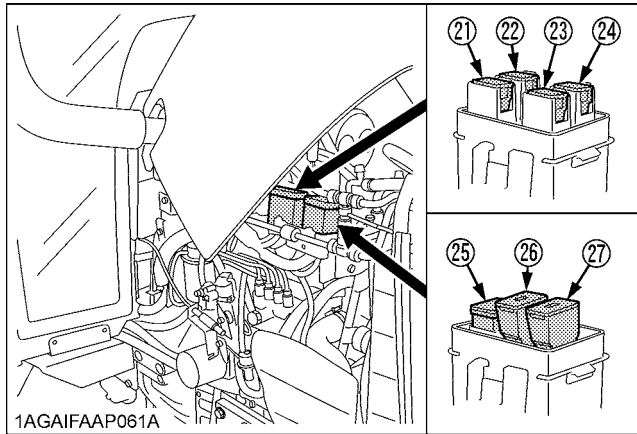

FUSE No.	CAPACITY (A)	Protected circuit
(1)	5	Radio
(2)	5	Air Conditioner (Control)
(3)	15	Wiper
(4)	5	Alternator, Engine, Heater
(5)	5	Meter Panel, OPC
(6)	10	Turn Signal, Stop Lamp
(7)	5	Meter, Radio (Back Up)
(8)	20	Head Light, Tail Lamp
(9)	20	Flasher (Hazard)
(10)	20	Spare Fuse
(11)	15	Work Light (Rear)
(12)	15	Work Light (Front)
(13)	15	Cigarette Lighter
(14)	30	Air Conditioner (Fan Motor)
(15)	10	Air Conditioner (Compressor)
(16)	15	Work Light (Front, Side)
(17)	15	Auxiliary Power
(18)	5	Starter Relay
(19)	20	Rear Window Defogger
(20)	20	Side Window Defogger
(21)	30	Key Switch
(22)	30	Work Light, Fuel Cut Solenoid
(23)	40	Air Conditioner
(24)	30	Electrical Outlet
(25)	100	Charge
(26)	50	Air Heater
(27)	50	Head Light, Hazard

◆ How to attach and detach the push-rivet assy.

● Detaching procedure

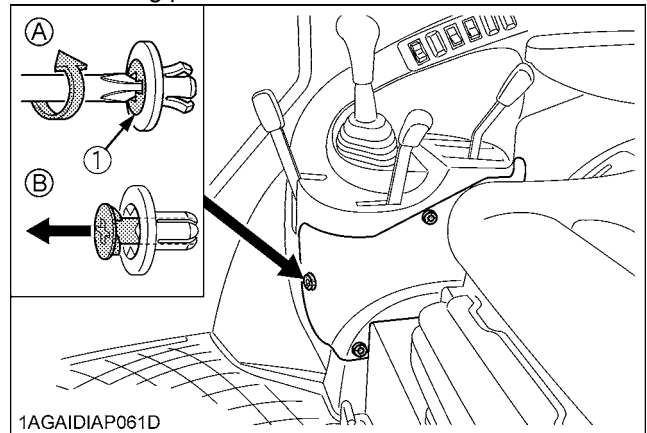

- (1) Center-rivet (A) Turn the center-rivet counterclockwise.
 (B) Pull out the push-rivet assy.

● Attaching procedure

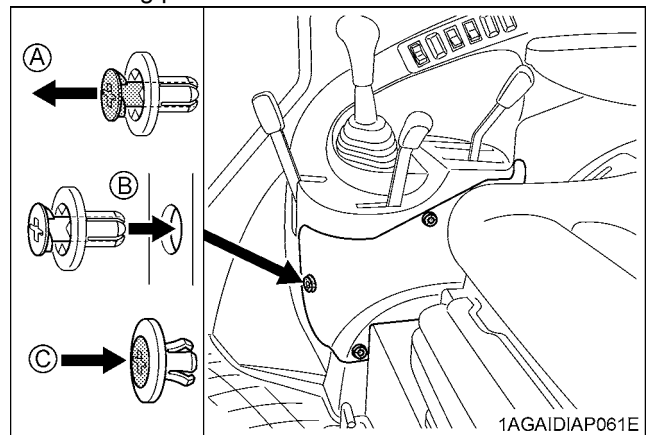

- (A) Pull out the center-rivet.
 (B) Attach the push-rivet assy.
 (C) Push the center-rivet.

◆ **Replacement procedure**
[100 Amp. Slow-blow fuse]

1. Disconnect the negative cord of the battery.
2. Remove the vinyl tape on the wire harness.
3. Detach the slow blow fuse case cap.

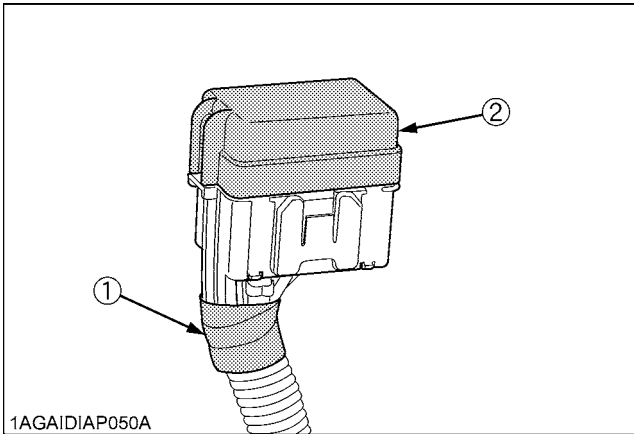

- (1) Vinyl tape
- (2) Slow blow fuse case cap

4. Pull out the slow-blow fuse assy from the fuse case.

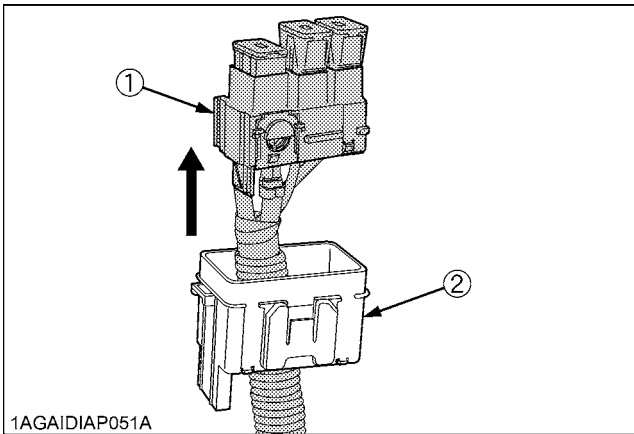

- (1) Slow blow fuse assy
- (2) Fuse case

5. Open the cover, remove the bolts and draw out the slow-blow fuse.

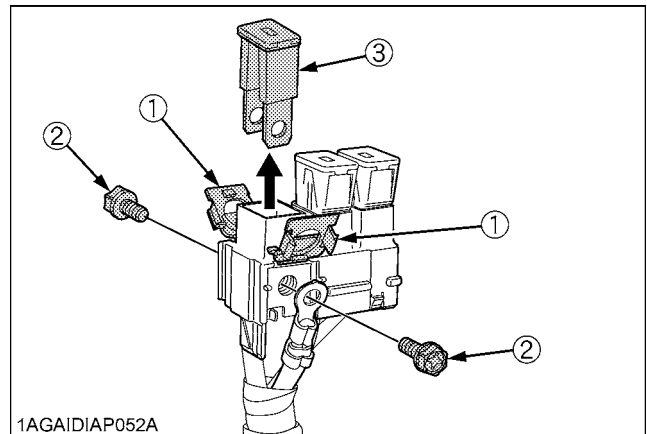

- (1) Cover
- (2) Bolt
- (3) Slow-blow fuse

■ **Replacing Light Bulb**

Light	Capacity
Head light	12 V, 55 / 60 W (H4)
Hazard light	12 V, 21 W
Turn signal	12 V, 21 W
Tail light	12 V, 5 W
Work light (for outer roof)	12 V, 55 W
Front work light	12 V, 21 W
Dome light (Room lamp)	12 V, 5 W

■ Replacing Head Lamp

CAUTION

To avoid personal injury:

- Be careful not to drop the bulb, hit anything against the lamp, apply excess force, and get the lamp scratched. If broken, glass may cause injury. Pay more attention to halogen lamps in particular, which have high pressure inside.
- Before replacing the lamp, be sure to turn off the light and wait until the bulb cools down, otherwise, you may get burned.

1. While pushing the right and left lock buttons, pull and remove the electrical connector.
2. Remove the rubber boot.
3. Remove the clamping fixture and take out the bulb.
4. Replace with a new bulb and reinstall the head lamp assembly in the reverse order.

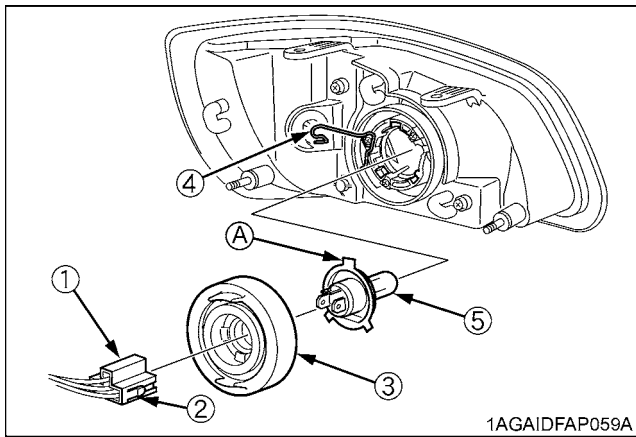

- (1) Electrical connector (A) "Base's wider projection to face upward"
- (2) Lock buttons
- (3) Rubber boot
- (4) Clamping fixture
- (5) Bulb

IMPORTANT :

- Be sure to use a new bulb of the specified wattage.
- Never touch the bulb surface (glass) with bare hands. Fingerprints, for example, may break the bulb.

■ Lubricating Points

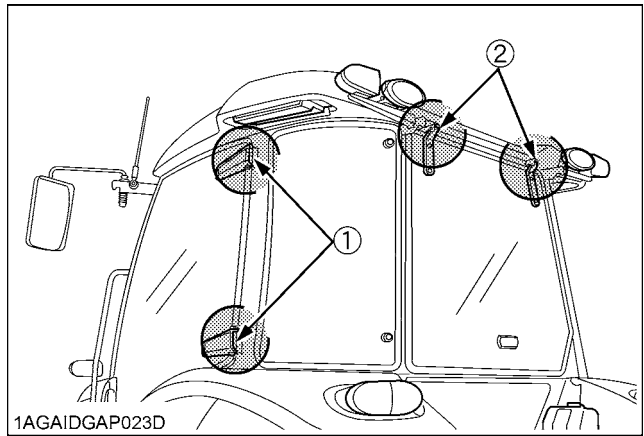

- (1) Door hinge
- (2) Rear window hinge

■ Adding Washer Liquid

Add a proper amount of automobile washer liquid.
(Tank capacity: 1.3 L (1.4 U.S.qts.))

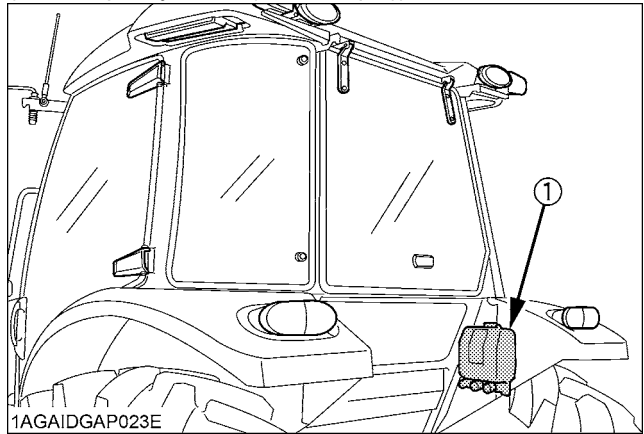

- (1) Washer liquid tank

■ Checking the Amount of Refrigerant (gas)

WARNING

To avoid personal injury:

- Liquid contact with eyes or skin may cause frostbite.
- In the event of a leakage, wear safety goggles. Escaping refrigerant can cause severe injuries to eyes.
- In contact with a flame, R134a refrigerant gives a toxic gas.
- Do not disconnect any part of the refrigeration circuit of the air conditioning system. Consult your local KUBOTA Dealer for assistance and service.

A shortage of refrigerant impairs the air-conditioner performance. Check the following points. If it is indicated that the amount of refrigerant is extremely low, ask your dealer to inspect and charge.

◆ **Checking procedure**

1. Run the air-conditioner in the following conditions.
 - Engine speed: About 1500 rpm
 - Temperature control dial: Maximum cooling position
 - Fan switch: Highest blow (HI)
 - Air-conditioner switch: ON
2. Look into the sight glass to see if the refrigerant is flowing through its circuit.

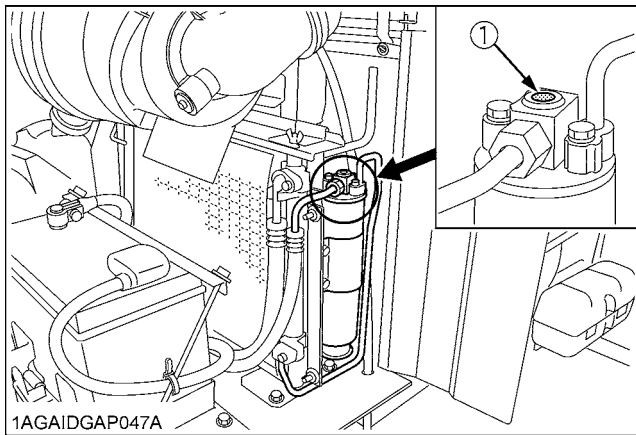

(1) Sight glass

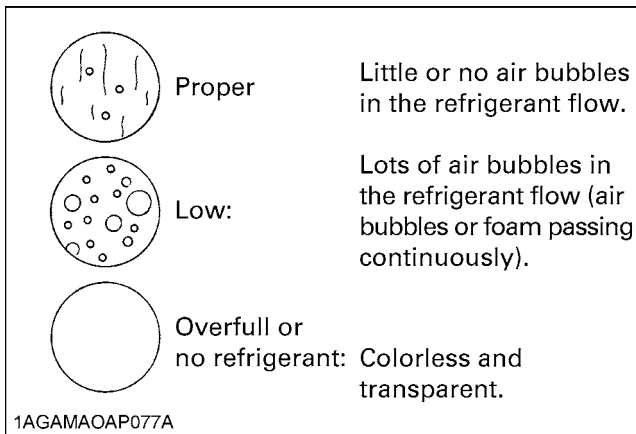

IMPORTANT :

- Charge only with R134a not R12 refrigerant (gas).

STORAGE



CAUTION

To avoid personal injury:

- Do not clean the machine while the engine is running.
- To avoid the danger of exhaust fume poisoning, do not operate the engine in a closed building without proper ventilation.
- When storing, remove the key from the key switch to avoid unauthorized persons from operating the tractor and getting injured.

TRACTOR STORAGE

If you intend to store your tractor for an extended period of time, follow the procedures outlined below.

These procedures will insure that the tractor is ready to operate with minimum preparation when it is removed from storage.

1. Check the bolts and nuts for looseness, and tighten if necessary.
2. Apply grease to tractor areas where bare metal will rust also to pivot areas.
3. Detach the weights from the tractor body.
4. Inflate the tires to a pressure a little higher than usual.
5. Change the engine oil and run the engine to circulate oil throughout the engine block and internal moving parts for about five minutes.
6. Keep the PTO clutch control lever at "DISENGAGE" position while tractor is stored for a long period of time.
7. With all implements lowered to the ground, coat any exposed hydraulic cylinder piston rods with grease.
8. Remove the battery from the tractor. Store the battery following the battery storage procedures.
(See "Checking Battery Condition" in "EVERY 100 HOURS" in "PERIODIC SERVICE" section.)
9. Keep the tractor in a dry place where the tractor is sheltered from the elements. Cover the tractor.
10. Store the tractor indoors in a dry area that is protected from sunlight and excessive heat. If the tractor must be stored outdoors, cover it with a waterproof tarpaulin.
Jack the tractor up and place blocks under the front and rear axles so that all four tires are off the ground. Keep the tires out of direct sunlight and extreme heat.

IMPORTANT :

- When washing the tractor, be sure to stop the engine. Allow sufficient time for the engine to cool before washing.
- Cover the tractor after the muffler and the engine have cooled down.

REMOVING THE TRACTOR FROM STORAGE

1. Check the tire air pressure and inflate the tires if they are low.
2. Jack the tractor up and remove the support blocks from under the front and rear axles.
3. Install the battery. Before installing the battery, be sure it is fully charged.
4. Check the fan belt tension.
5. Check all fluid levels (engine oil, transmission/hydraulic oil, engine coolant and any attached implements).
6. Start the engine. Observe all gauges. If all gauges are functioning properly and reading normal, move the tractor outside. Once outside, park the tractor and let the engine idle for at least five minutes. Shut the engine off and walk around tractor and make a visual inspection looking for evidence of oil or water leaks.
7. With the engine fully warmed up, release the parking brake and test the brakes for proper adjustment as you move forward. Adjust the brakes as necessary.

TROUBLESHOOTING

ENGINE TROUBLESHOOTING

If something is wrong with the engine, refer to the table below for the cause and its corrective measure.

Trouble		Cause	Countermeasure
Engine is difficult to start or won't start.		<ul style="list-style-type: none"> No fuel flow. 	<ul style="list-style-type: none"> Check the fuel tank and the fuel filter. Replace filter if necessary.
		<ul style="list-style-type: none"> Air or water is in the fuel system. 	<ul style="list-style-type: none"> Check to see if the fuel line coupler bolt and nut are tight. Bleed the fuel system (See "Bleeding Fuel System" in "SERVICE AS REQUIRED" in "PERIODIC SERVICE" section.)
		<ul style="list-style-type: none"> In winter, oil viscosity increases, and engine revolution is slow. 	<ul style="list-style-type: none"> Use oils of different viscosities, depending on ambient temperatures. Use engine block heater (Optional)
		<ul style="list-style-type: none"> Battery becomes weak and the engine does not turn over quick enough. 	<ul style="list-style-type: none"> Clean battery cables & terminals. Charge the battery. In cold weather, always remove the battery from the engine, charge and store it indoors. Install it on the tractor only when the tractor is going to be used.
		<ul style="list-style-type: none"> Intake air heater system trouble. 	<ul style="list-style-type: none"> Check to see if the slow blow fuse of the intake air heater blows. Check to see if the intake air heater functions in cold weather.
Insufficient engine power.		<ul style="list-style-type: none"> Insufficient or dirty fuel. The air cleaner is clogged. 	<ul style="list-style-type: none"> Check the fuel system. Clean or replace the element.
Engine stops suddenly.		<ul style="list-style-type: none"> Insufficient fuel. 	<ul style="list-style-type: none"> Refuel. Bleed the fuel system if necessary.
Exhaust fumes are colored.	Black	<ul style="list-style-type: none"> Fuel quality is poor. Too much oil. The air cleaner is clogged. 	<ul style="list-style-type: none"> Change the fuel and fuel filter. Check the proper amount of oil. Clean or replace the element.
	Blue white	<ul style="list-style-type: none"> The inside of exhaust muffler is dumped with fuel. Injection nozzle trouble. Fuel quality is poor. 	<ul style="list-style-type: none"> Check to see if the intake air heater functions in cold weather. Heat the muffler by applying load to the engine. Check the injection nozzle. Change the fuel and fuel filter.
Engine overheats		<ul style="list-style-type: none"> Engine overloaded 	<ul style="list-style-type: none"> Shift to lower gear or reduce load.
		<ul style="list-style-type: none"> Low coolant level 	<ul style="list-style-type: none"> Fill cooling system to the correct level; check radiator and hoses for loose connections or leaks.
		<ul style="list-style-type: none"> Loose or defective fan belt 	<ul style="list-style-type: none"> Adjust or replace fan belt.
		<ul style="list-style-type: none"> Dirty radiator core or grille screens 	<ul style="list-style-type: none"> Remove all trash.
		<ul style="list-style-type: none"> Coolant flow route corroded 	<ul style="list-style-type: none"> Flush cooling system.

If you have any questions, contact your local KUBOTA Dealer.

OPTIONS

Consult your local KUBOTA Dealer for further details.

- Engine Block Heater
For extremely cold weather starting
- Double Acting Remote Hydraulic Control Valve with Detents and Self-Cancelling
- Flow Control Valve Kit
- Double Acting Remote Hydraulic Control Valve with Detents and Self-Cancelling for Flow Control Valve
- Double Acting Remote Hydraulic Control Valve with Float Position
- Clevis for Drawbar
- Grille guard
- Front end weights
For front ballast
- Rear Wheel Weights
For rear ballast
- Creep Speed Kit
- Defogger Kit
- 80" Wide Axle
- Hydraulic High Capacity Lift Cylinder (F12 / R12, F24 / R24 model: standard)
- Rear Window Wiper Kit with Washer
- 540 / 1000 rpm PTO Speed Kit
- Radio with CD player
- Rear Cast Iron Disk
- Alternator Kit 80A

MOUNTING THE SUPPORT PLATE

■ Installation Procedures

1. Insert the support plate through the CD player mounting opening of the inner roof.

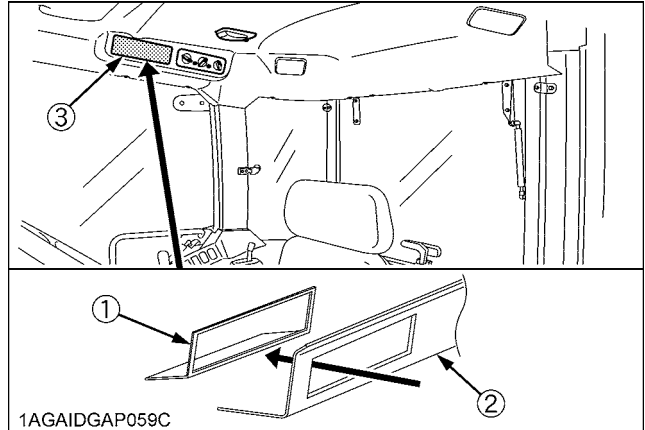

- (1) Support plate
- (2) Inner roof
- (3) CD player mounting opening

2. Insert the mounting collar into the inner roof and support plate.

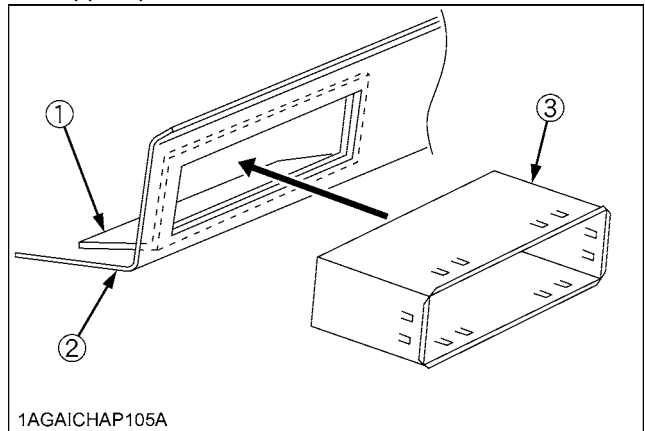

- (1) Support plate
- (2) Inner roof
- (3) Mounting collar

3. Bend the mounting tabs of the mounting collar out with a screwdriver.

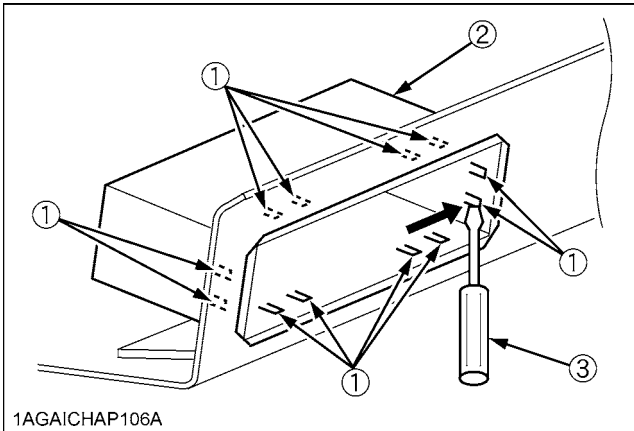

- (1) Mounting tabs
 (2) Mounting collar
 (3) Screwdriver

4. Connect the antenna lead to the CD player.
 5. Connect the power connector to the CAB wire harness.

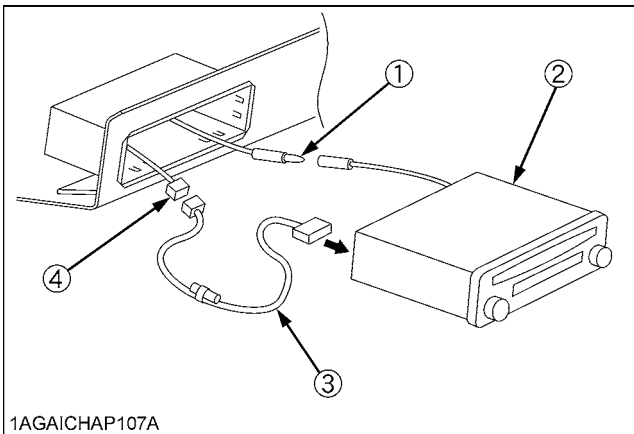

- (1) Antenna lead
 (2) CD player
 (3) Power connector
 (4) CAB wire harness

6. Insert the CD player into the mounting collar and push it in until "click" is heard. (The CD player is secured to the mounting collar by the side tabs.)

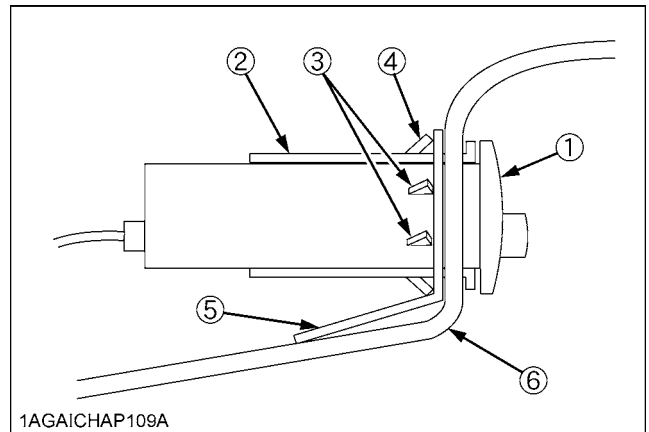
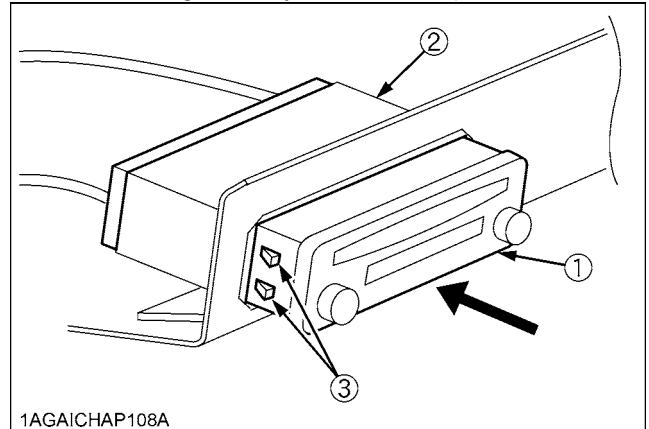

- (1) CD player
 (2) Mounting collar
 (3) Side tabs
 (4) Mounting tabs
 (5) Support plate
 (6) Inner roof



- U.S.A. : **KUBOTA TRACTOR CORPORATION**
3401 Del Amo Blvd., Torrance, CA 90503, U.S.A.
Telephone : (310)370-3370
- Western Division : 1175 S. Guild Av., Lodi, CA 95240
Telephone : (209)334-9910
- Central Division : 14855 FAA Blvd., Fort Worth, TX 76155
Telephone : (817)571-0900
- Northern Division : 6300 at One Kubota Way, Groveport, OH 43125
Telephone : (614)835-1100
- Southeast Division : 1025 Northbrook Parkway, Suwanee, GA 30024
Telephone : (770)995-8855
- Canada : **KUBOTA CANADA LTD.**
5900 14th Avenue, Markham, Ontario, L3S 4K4, Canada
Telephone : (905)294-7477
- France : **KUBOTA EUROPE S.A.S**
19-25, Rue Jules Vercey, Z.I. BP88, 95101 Argenteuil Cedex, France
Telephone : (33)1-3426-3434
- Italy : **KUBOTA EUROPE S.A.S Italy Branch**
Via Grandi, 29 20068 Peschiera Borrome (MI) Italy
Telephone : (39)02-51650377
- Germany : **KUBOTA (DEUTSCHLAND) GmbH**
Senefelder Str. 3-5 63110 Rodgau /Nieder-Roden, Germany
Telephone : (49)6106-873-0
- U.K. : **KUBOTA (U.K.) LTD.**
Dormer Road, Thame, Oxfordshire, OX9 3UN, U.K.
Telephone : (44)1844-214500
- Spain : **KUBOTA ESPAÑA S.A.**
Avenida Recomba No.5, Poligono Industrial la Laguna, Leganes, 28914 (Madrid) Spain
Telephone : (34)91-508-6442
- Australia : **KUBOTA TRACTOR AUSTRALIA PTY LTD.**
25-29 Permas Way, Truganina, VIC 3029, Australia
Telephone : (61)-3-9394-4400
- Malaysia : **SIME KUBOTA SDN. BHD.**
No.3 Jalan Sepadu 25/123 Taman Perindustrian Axis,
Seksyen 25, 40400 Shah Alam, Selangor Darul Ehsan Malaysia
Telephone : (60)3-736-1388
- Philippines : **KUBOTA PHILIPPINES, INC.**
155 Panay Avenue, South Triangle Homes, 1103 Quezon City, Philippines
Telephone : (63)2-9201071
- Taiwan : **SHIN TAIWAN AGRICULTURAL MACHINERY CO., LTD.**
16, Fengping 2nd Rd, Taliaw Shiang Kaohsiung 83107, Taiwan R.O.C.
Telephone : (886)7-702-2333
- Indonesia : **P.T. KUBOTA INDONESIA**
JALAN. Setyabudi 279, Semarang, Indonesia
Telephone : (62)-24-7472849
- Thailand : **SIAM KUBOTA CORPORATION CO., LTD.**
101/19-24 Moo 20, Navanakorn Industrial Estate, Tambon Khlongnueng, Amphur Khlongluang,
Pathumthani 12120, THAILAND
Telephone : (66)2-909-0300
- Korea : **KUBOTA KOREA CO., LTD.**
106-24 Mongsan-Ri, Mankyung-Up, Kimje-City, Chonrapuk-Do, KOREA
Telephone : (82)-63-544-5822
- India : **KUBOTA AGRICULTURAL MACHINERY INDIA PVT. LTD.**
Regus, Level 2 Altius, Olympia Tech Park, No.1 SIDCO Industrial Estate, Guindy, Chennai 600032, TN, India
Telephone : (91)-44-4299-4237
- Vietnam : **KUBOTA VIETNAM CO., LTD.**
Lot B-3A2-CN, My Phuoc 3 Industrial Park, Ben Cat District, Binh Duong Province, Vietnam
Telephone : (84)-650-3577-507

KUBOTA Corporation

English (Australia)
Code No. 3C793-9971-1

OPERATOR'S MANUAL

KUBOTA TRACTOR

**MODELS M6040
M7040
M8540
M9540**



1AGAIDGAP001A

M
6
0
4
0
·
M
7
0
4
0
·
M
8
5
4
0
·
M
9
5
4
0

READ AND SAVE THIS MANUAL



FOREWORD

Thank you very much for choosing the CAB model of the M series tractor.

This operator's Manual covers the operation, inspection and preventive maintenance instructions that is specific to the oceania models. For other information and instructions, refer to the separately issued operator's manual for the sister models. (M6040, M7040, M8540, M9540)

Please read both manuals carefully, to operate the machine properly and safety.

Proper daily inspection, servicing and lubrication keeps your machine in good condition.

KUBOTA Corporation is ...

Since its inception in 1890, KUBOTA Corporation has grown to rank as one of the major firms in Japan.

To achieve this status, the company has through the years diversified the range of its products and services to a remarkable extent, until today, 19 plants and 16,000 employees produce over 1,000 different items, large and small.

All these products and all the services which accompany them, however, are unified by one central commitment. KUBOTA makes products which, taken on a national scale, are basic necessities. Products which are indispensable, products intended to help individuals and nations fulfill the potential inherent in their environment. For KUBOTA is the Basic Necessities Giant.

This potential includes water supply, food from the soil and from the sea, industrial development, architecture and construction, transportation.

Thousands of people depend on KUBOTA's know-how, technology, experience and customer service. You too can depend on KUBOTA.

SAFETY FIRST

This symbol, the industry's "Safety Alert Symbol", is used throughout this manual and on labels on the machine itself to warn of the possibility of personal injury. Read these instructions carefully. It is essential that you read the instructions and safety regulations before you attempt to assemble or use this unit.

 **DANGER :** Indicates an imminently hazardous situation which, if not avoided, will result in death or serious injury.

 **WARNING :** Indicates a potentially hazardous situation which, if not avoided, could result in death or serious injury.

 **CAUTION :** Indicates a potentially hazardous situation which, if not avoided, may result in minor or moderate injury.

IMPORTANT : Indicates that equipment or property damage could result if instructions are not followed.

NOTE : Gives helpful information.

CONTENTS

▲ SAFE OPERATION	1
SPECIFICATIONS	1
SPECIFICATION TABLE	1
TRAVELING SPEEDS	3
INSTRUMENT PANEL AND CONTROLS	4
OPERATING THE TRACTOR	10
STARTING	10
Operator's Seat	10
Light Switch	11
Turn Signal / Hazard Light Switch	11
With Trailer Connector	11
PTO RPM / TRAVEL SPEED MONITOR	12
PTO Speed Display Mode Switching	12
PARKING	13
Parking Brake Lever	13
Gear Locked Parking Lever	13
OPERATING TECHNIQUES	14
Trailer Electrical Outlet	14
PTO	15
PTO OPERATION	15
PTO Gear Shift Lever	15
PTO Clutch Control Lever	15
PTO Clutch Control Switch	16
LCD Monitor Message	17
THREE-POINT HITCH & DRAWBAR	18
3-POINT HITCH	18
Remote Hitch UP / DOWN Lever	18
DRAWBAR	18
Adjusting Drawbar Length	18
Swing Drawbar	19
HYDRAULIC UNIT	20
REMOTE HYDRAULIC CONTROL SYSTEM	20
Remote Control Valve	20
Remote Control Valve Lever	20
TIRES, WHEELS AND BALLAST	22
TIRES	22
Inflation Pressure	22
Dual Tires	22
WHEEL ADJUSTMENT	22
Front Wheels (with four wheel drive)	23
Rear Wheels	24
MAINTENANCE	25

SERVICE INTERVALS	25
PERIODIC SERVICE.....	28
EVERY 100 HOURS	28
Adjusting Parking Brake Lever	28
Checking Gear Locked Parking Lever	28
SERVICE AS REQUIRED.....	28
Replacing Fuse.....	28
Replacing Light Bulb.....	30
OPTIONS.....	31



SAFE OPERATION

Careful operation is your best insurance against an accident.

Read and understand this manual carefully before operating the tractor.

All operators, no matter how much experience they may have, should read this and other related manuals before operating the tractor or any implement attached to it. It is the owner's obligation to instruct all operators in safe operation.

1. BEFORE OPERATING THE TRACTOR

1. Know your equipment and its limitations. Read this entire manual before attempting to start and operate the tractor.
2. Pay special attention to the danger, warning and caution labels on the tractor.
3. KUBOTA recommends the use of a CAB or Roll Over Protective Structures (ROPS) and seat belt in almost all applications. This combination will reduce the risk of serious injury or death, should the tractor be upset. If the CAB or ROPS is loosened or removed for any reason, make sure that all parts are reinstalled correctly before operating the tractor.
Never modify or repair a CAB or ROPS because welding, bending, drilling, grinding, or cutting may weaken the structure.
A damaged CAB or ROPS structure must be replaced, not repaired or revised. If any structural member of the CAB or ROPS is damaged, replace the entire structure at your local KUBOTA Dealer.

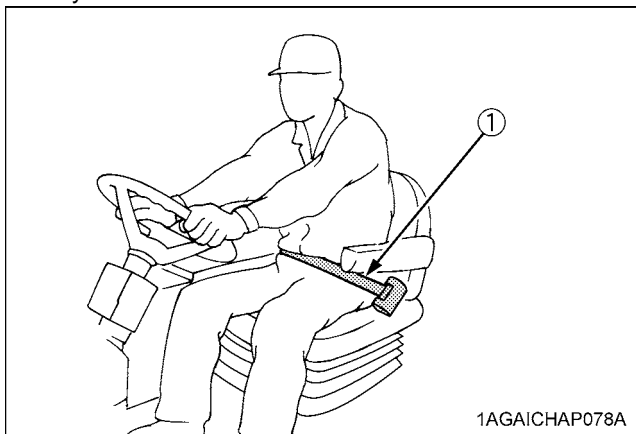

(1) Seat belt

4. Always use the seat belt if the tractor has a CAB or ROPS. Do not use the seat belt if there is no CAB or ROPS. Check the seat belt regularly and replace if frayed or damaged.

5. Do not operate tractor or any implement attached to it while under the influence of alcohol, medication, controlled substances or while fatigued.
6. Carefully check the vicinity before operating tractor or any implement attached to it. Check for overhead clearance which may interfere with a CAB or ROPS. Do not allow any bystanders around or near tractor during operation.
7. Before allowing other people to use your tractor, explain how to operate and have them read this manual before operation.
8. Never wear loose, torn, or bulky clothing around tractor. It may catch on moving parts or controls, leading to the risk of an accident. Use additional safety items, e.g. hard hat, safety boots or shoes, eye and hearing protection, gloves, etc., as appropriate or required.
9. Do not allow passengers to ride on any part of the tractor at anytime. The operator must remain in the tractor seat during operation.
10. Check brakes, clutch, linkage pins and other mechanical parts for improper adjustment and wear. Replace worn or damaged parts promptly. Check the tightness of all nuts and bolts regularly. (For further details, see "MAINTENANCE" section.)
11. Keep your tractor clean. Dirt, grease, and trash build up may contribute to fires and lead to personal injury.
12. Use only implements meeting the specifications listed under "IMPLEMENT LIMITATIONS" in this manual or implements approved by KUBOTA.
13. Use proper weights on the front or rear of the tractor to reduce the risk of upsets. When using the front loader, put an implement or ballast on the 3-point hitch to improve stability. Follow the safe operating procedures specified in the implement or attachment manual.

14. The narrower the tread, the greater the risk of a tractor upset. For maximum stability, adjust the wheels to the widest practical tread width for your application. (See "TIRES, WHEELS AND BALLAST" section.)

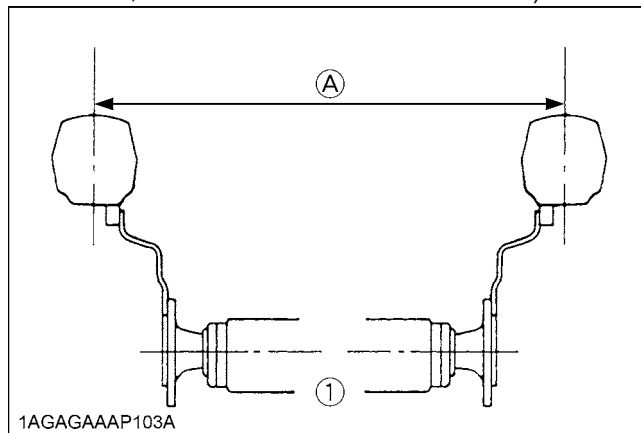

(1) Rear wheels (A) Tread Width

15. Do not modify the tractor. Unauthorized modification may affect the function of the tractor, which may result in personal injury.

2. OPERATING THE TRACTOR

Operator safety is a priority. Safe operation, specifically with respect to overturning hazards, entails understanding the equipment and environmental conditions at the time of use. Some prohibited uses which can affect overturning hazards include traveling and turning with implements and loads carried too high etc. This manual sets forth some of the obvious risks, but the list is not, and cannot be, exhaustive. It is the operator's responsibility to be alert for any equipment or environmental condition that could compromise safe operation.

◆ Starting

1. Always sit in the operator's seat when starting engine or operating levers or controls. Adjust seat per instructions in the operating the tractor section. Never start engine while standing on the ground.
2. Before starting the engine, make sure that all levers (including auxiliary control levers) are in their neutral positions, that the parking brake is engaged, and that both the clutch and the Power Take-Off (PTO) are disengaged or "OFF".
Fasten the seat belt if the tractor has a CAB, a fixed ROPS or a foldable ROPS in the upright and locked position.
3. Do not start engine by shorting across starter terminals or bypassing the safety start switch. Machine may start in gear and move if normal starting circuitry is bypassed.
4. Do not operate or idle engine in a non-ventilated area. Carbon monoxide gas is colorless, odorless, and deadly.

5. Check before each use that operator presence controls are functioning correctly. Test safety systems. (See "Checking Engine Start System" in "EVERY 50 HOURS" in "PERIODIC SERVICE" section.)
Do not operate unless they are functioning correctly.

◆ Working

1. Pull only from the drawbar. Never hitch to axle housing or any other point except drawbar; such arrangements will increase the risk of serious personal injury or death due to a tractor upset.

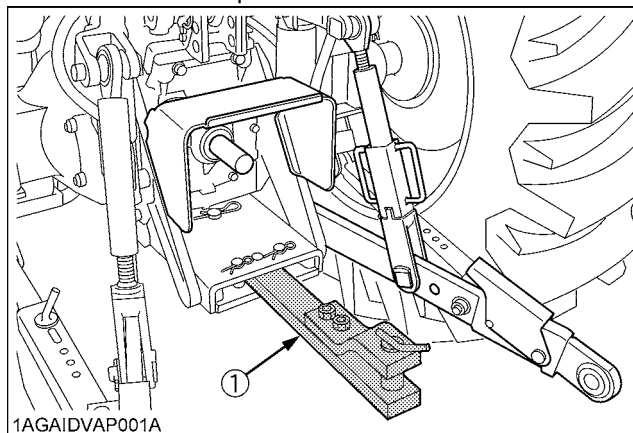

(1) Drawbar

2. Keep all shields and guards in place. Replace any that are missing or damaged.
3. Avoid sudden starts. To avoid upsets, slow down when turning, on uneven ground, and before stopping.
4. The tractor cannot turn with the rear wheel or 4-wheel differential locked and attempting to do so could be dangerous.
5. Do not operate near ditches, holes, embankments, or other ground surface features which may collapse under the tractor's weight. The risk of tractor upset is even higher when the ground is loose or wet. Tall grass can hide obstacles, walk the area first to be sure.
6. Watch where you are going at all times. Watch for and avoid obstacles. Be alert at row ends, near trees, and other obstructions.
7. When working in groups, always let the others know what you are going to do before you do it.
8. Never try to get on or off a moving tractor.
9. Do not stand between tractor and implement or trailed vehicle unless parking brake is applied.

◆ Safety for children

Tragedy can occur if the operator is not alert to the presence of children. Children generally are attracted to machines and the work they do.

1. Never assume that children will remain where you last saw them.
2. Keep children out of the work area and under the watchful eye of another responsible adult.
3. Be alert and shut your machine down if children enter the work area.

4. Never carry children on your machine. There is no safe place for them to ride. They may fall off and be run over or interfere with your control of the machine.
5. Never allow children to operate the machine even under adult supervision.
6. Never allow children to play on the machine or on the implement.
7. Use extra caution when backing up. Look behind and down to make sure area is clear before moving.
8. When parking your machine if at all possible park on a firm, flat and level surface; if not, park across a slope. Set the parking brake(s), lower the implements to the ground, remove the key from the ignition and lock the cab door (if equipped) and chock the wheels.

◆ Operating on slopes

Slopes are major factor related to loss-of-control and tip-over accidents, which can result in severe injury or death. All slopes require extra caution.

1. To avoid upsets, always back up steep slopes. If you cannot back up the slope or if you feel uneasy on it, do not operate on it. Stay off slopes too steep for safe operation.
2. Driving forward out of a ditch, mired condition or up a steep slope increases the risk of a tractor to be upset backward. Always back out of these situations. Extra caution is required with four-wheel drive models because their increased traction can give the operator false confidence in the tractor's ability to climb slopes.
3. Keep all movement on slopes slow and gradual. Do not make sudden changes in speed, direction or apply brake and make sudden motions of the steering wheel.
4. Avoid disengaging the clutch or changing gears speed when climbing or going down a slope. If on a slope disengaging the clutch or changing gears to neutral could cause loss of control.
5. Special attention should be made to the weight and location of implements and loads as such will affect the stability of the tractor.
6. To improve stability on slope, set widest wheel tread as shown in "TIRES, WHEELS AND BALLAST" section.
Follow recommendations for proper ballasting.

◆ Driving the tractor on the road

1. Lock the two brake pedals together to help assure straight-line stops. Uneven braking at road speeds could cause the tractor to tip over.

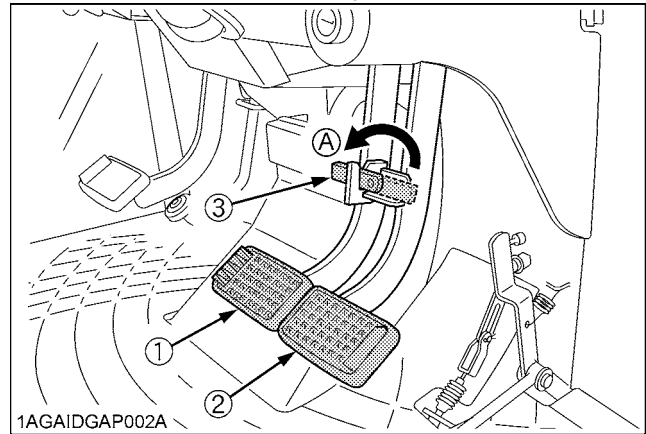

- (1) Brake Pedal (LH) (A) Whenever travelling on the road
 (2) Brake Pedal (RH)
 (3) Brake Pedal Lock

2. Check the front wheel engagement. The braking characteristics are different between two and four wheel drive. Be aware of the difference and use carefully.
3. Always slow the tractor down before turning. Turning at high speed may tip the tractor over.
4. Turn the headlights on. Dim them when meeting another vehicle.
5. Drive at speeds that allow you to maintain control at all times.
6. Do not apply the differential lock while traveling at road speeds. The tractor may run out of control.
7. Avoid sudden motions of the steering wheel as they can lead to a dangerous loss of stability. The risk is especially great when the tractor is traveling at road speeds.
8. Do not operate an implement while the tractor is on the road. Lock the 3-point hitch in the raised position.

3. PARKING THE TRACTOR

1. Disengage the PTO, lower all implements to the ground, place all control levers in their neutral positions, set the parking brake, stop the engine, and remove the key.
2. Make sure that the tractor has come to a complete stop before dismounting.
3. Avoid parking on steep slopes, if at all possible park on a firm and level surface; if not, park across a slope with chock the wheels.
Failure to comply with this warning may allow the tractor to move and could cause injury or death.

4. OPERATING THE PTO

1. Wait until all moving components have completely stopped before getting off the tractor, connecting, disconnecting, adjusting, cleaning, or servicing any PTO driven equipment.
2. Keep the PTO shaft cover in place at all times. Replace the PTO shaft cap when the shaft is not in use.

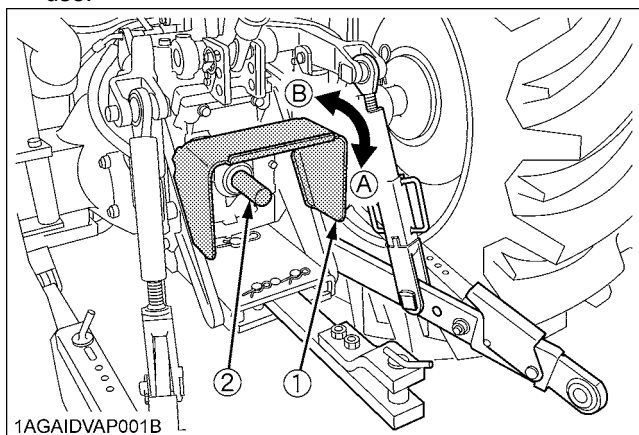

(1) PTO Shaft cover (A) "NORMAL POSITION"
 (2) PTO Shaft cap (B) "RAISED POSITION"

3. Before installing or using PTO driven equipment, read the manufacturer's manual and review the safety labels attached to the equipment.
 To prevent PTO driven equipment from improper or unsafe use, select the lower speed (540rpm) unless the higher one is specifically recommended as safe by the equipment manufacture.
4. When operating stationary PTO driven equipment, always apply the tractor parking brake and place chocks behind and in front of the rear wheels. Stay clear of all rotating parts. Never step over rotating parts.

5. USING 3-POINT HITCH

1. Use the 3-point hitch only with equipment designed for 3-point hitch usage.
2. When using a 3-point hitch mounted implement, be sure to install the proper counterbalance weight on the front of the tractor.
3. When transporting on the road, set the implement lowering speed knob in the "LOCK" position to hold the implement in the raised position.

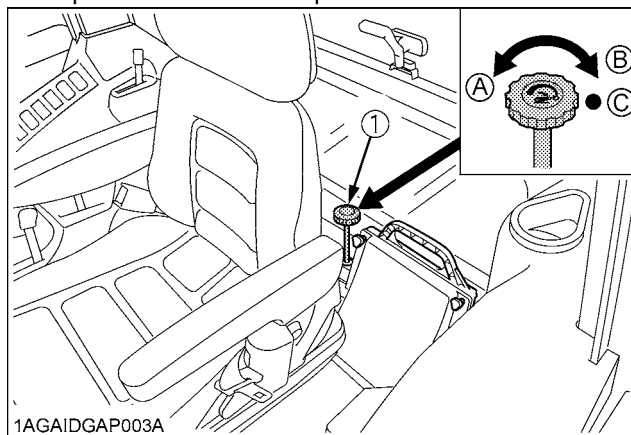

(1) 3-point hitch lowering speed knob (A) "FAST"
 (B) "SLOW"
 (C) "LOCK"

6. SERVICING THE TRACTOR

Before servicing the tractor, park it on a firm, flat and level surface, set the parking brake, lower all implements to the ground, place the gear shift lever in neutral, stop the engine and remove the key.

1. Allow the tractor time to cool off before working on or near the engine, muffler, radiator, etc.
2. Always stop the engine before refueling. Avoid spills and overfilling.
3. Do not smoke when working around battery or when refueling. Keep all sparks and flames away from battery and fuel tank. The battery presents an explosive hazard, because it gives off hydrogen and oxygen especially when recharging.
4. Before "jump starting" a dead battery, read and follow all of the instructions. (See "JUMP STARTING" in "OPERATING THE ENGINE" section.)
5. Keep first aid kit and fire extinguisher handy at all times.
6. Do not remove radiator cap while coolant is hot. When cool, slowly rotate cap to the first stop and allow sufficient time for excess pressure to escape before removing the cap completely. If the tractor has a coolant recovery tank, add coolant or water to the tank, not the radiator. (See "Checking Coolant Level" in "DAILY CHECK" in "PERIODIC SERVICE" section.)

7. Disconnect the battery's ground cable before working on or near electric components.
8. To avoid the possibility of battery explosion, do not use or charge the refillable type battery if the fluid level is below the LOWER (lower limit level) mark. Check the fluid level regularly and add distilled water as required so that the fluid level is between the UPPER and LOWER levels.
9. To avoid sparks from an accidental short circuit, always disconnect the battery's ground cable (-) first and reconnect it last.

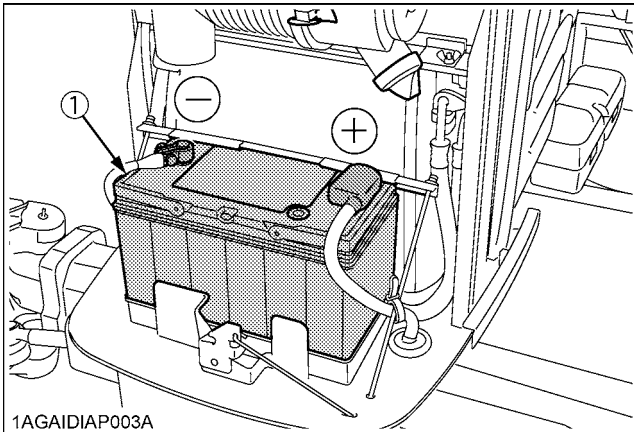

(1) Battery

10. Do not attempt to mount a tire on a rim. This should be done by a qualified person with the proper equipment.
11. Always maintain the correct tire pressure. Do not inflate tires above the recommended pressure shown in the operator's manual.

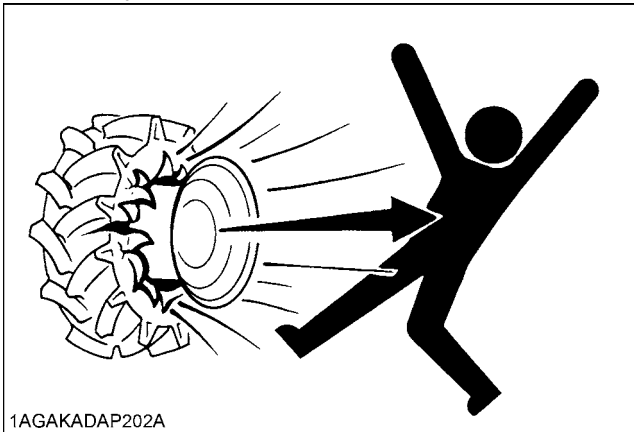

12. Securely support the tractor when either changing wheels or adjusting the wheel tread width.
13. Make sure that wheel bolts have been tightened to the specified torque.
14. Do not work under any hydraulically supported devices. They can settle, suddenly leak down, or be accidentally lowered. If it is necessary to work under tractor or any machine elements for servicing or adjustment, securely support them with stands or suitable blocking beforehand.

15. Escaping hydraulic fluid under pressure has sufficient force to penetrate skin, causing serious personal injury. Before disconnecting hydraulic lines, be sure to release all residual pressure. Before applying pressure to the hydraulic system, make sure that all connections are tight and that all lines, pipes, and hoses are free of damage.

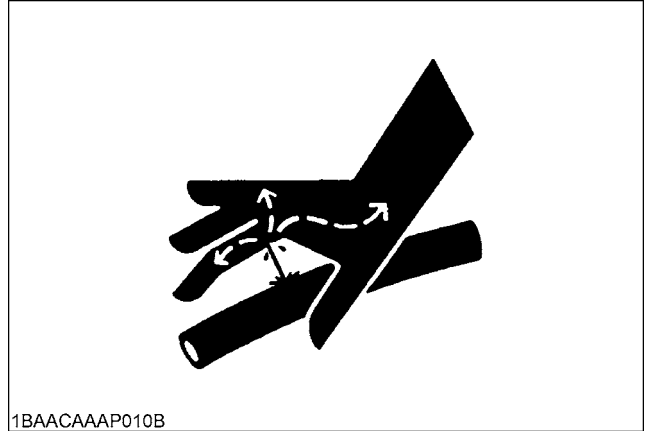

16. Fluid escaping from pinholes may be invisible. Do not use hands to search for suspected leaks; use a piece of cardboard or wood. Use of safety goggles or other eye protection is also highly recommended. If injured by escaping fluid, see a medical doctor at once. This fluid will produce gangrene or severe allergic reaction.

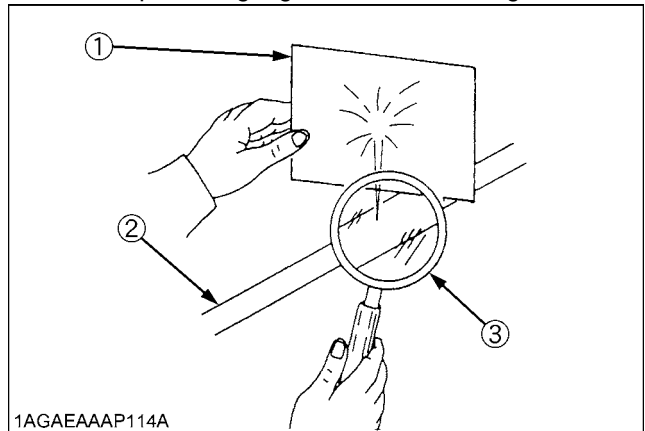

(1) Cardboard
 (2) Hydraulic line
 (3) Magnifying glass

7. DANGER, WARNING AND CAUTION LABELS

(1) Part No. 6C090-4958-2
Do not get your hands close to engine fan and fan belt.



1AGAIAZAP110A

(2) Part No. 3N300-4958-1
Do not touch hot surface like muffler, etc.

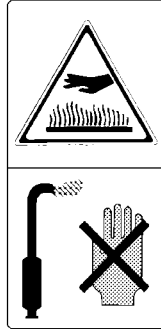

1AGAIAZAP071A

(3) Part No. 6C040-4741-1
No fire



1AGAIAZAP104A

(4) Part No. 3A851-7295-1

CAUTION REFRIGERANT UNDER HIGH PRESSURE

Improper service methods may cause injury. Air conditioning system should be serviced by qualified personnel. See Repair Manual.

Refrigerant: HFC134a Max. 0.95kg (2.09lbs.) USE ONLY Min. 0.85kg (1.87lbs.)
Oil: ND-OIL OR EQUIVALENT 8 SAE J-639

MFD. BY DENSO CORPORATION JAPAN.

ATTENTION REFRIGERANT SOUS HAUTE PRESSION

Un entretien incorrect peut provoquer des blessures. Le système de climatisation doit être entretenu par une personne qualifiée. Voir le manuel de réparation.

Refrigerant: HFC134a Max. 0.95kg (2.09lbs.) UNIQUEMENT Min. 0.85kg (1.87lbs.)
Huile: ND-OIL OR EQUIVALENTE 8 SAE J-639

FABRIQUE PAR DENSO CORPORATION JAPON.

09

1AGAIDGAP074A

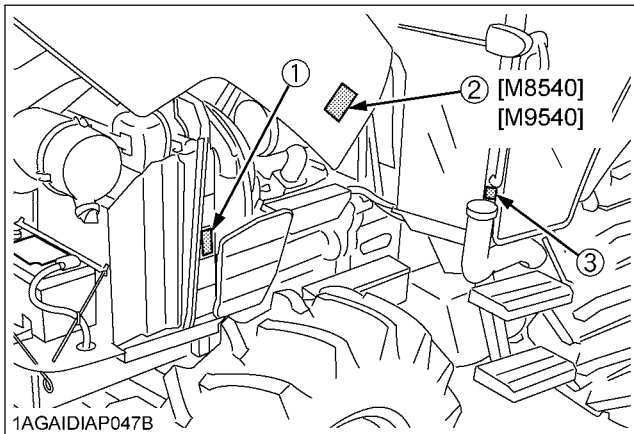



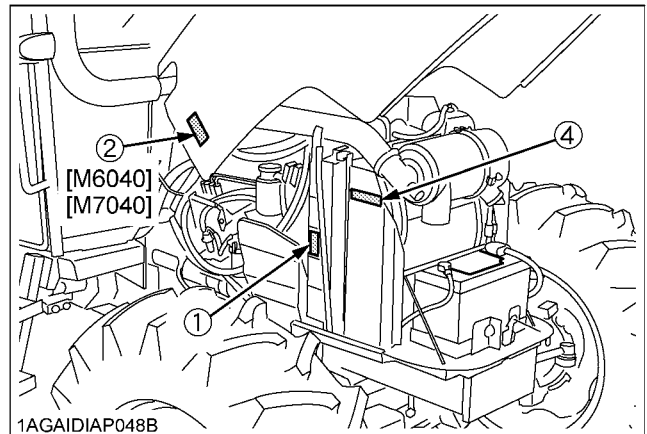



1AGAIDIAP047B



1AGAIDIAP048B

1AGAIDVAP003A

(1) Part No. 3N300-9892-1

<p>⚠ DANGER/POISON</p>			<p>KEEP OUT OF REACH OF CHILDREN. DO NOT TIP. DO NOT OPEN BATTERY.</p>	
<p> SHIELD EYES. EXPLOSIVE GASES CAN CAUSE BLINDNESS OR INJURY.</p>	<p> NO • SPARKS • FLAMES • SMOKING</p>	<p> SULFURIC ACID CAN CAUSE BLINDNESS OR SEVERE BURNS.</p>	<p>FLUSH EYES IMMEDIATELY WITH WATER.  GET MEDICAL HELP FAST.</p>	
<p>PROPOSITION 65 WARNING BATTERY POSTS, TERMINALS, AND RELATED ACCESSORIES CONTAIN LEAD AND LEAD COMPOUNDS, CHEMICALS KNOWN TO THE STATE OF CALIFORNIA TO CAUSE CANCER AND REPRODUCTIVE HARM. WASH HANDS AFTER HANDLING.</p>			<p>HYDROMETER</p> <p></p>	
<p> RECYCLE</p> <p>105E41R 12V</p> <p>RESERVE CAPACITY (MIN) 160 COLD CRANKING AMPS(-18°C) 900</p>				

1AGAICHAP100A

(2) Part No. TA040-4965-2 [M6040, M7040]

<p> </p>	<p>⚠ DANGER</p> <p>TO AVOID POSSIBLE INJURY OR DEATH FROM A MACHINE RUNAWAY.</p> <ol style="list-style-type: none"> Do not start engine by shorting across starter terminals or bypassing the safety start switch. Machine may start in gear and move if normal starting circuitry is bypassed. Start engine only from operator's seat with transmission and PTO OFF. Never start engine while standing on the ground.
---	--

1AGAIAZAP009A

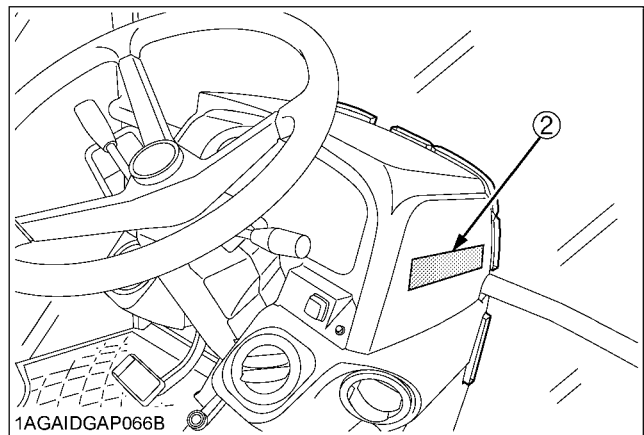
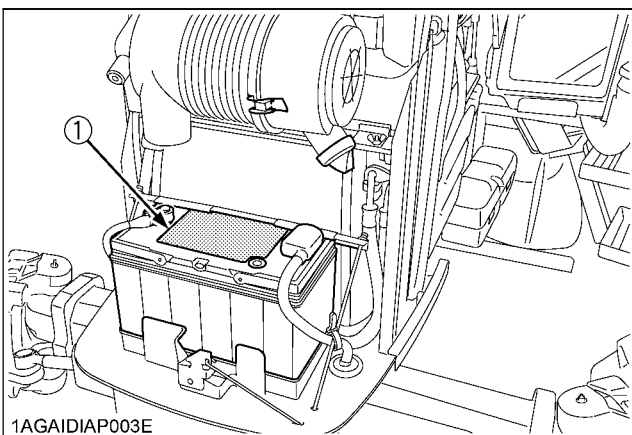

1AGAIDIAP055B

(1) Part No. 3F240-9857-1 [Hydraulic shuttle model]

 WARNING
<p>To avoid free wheeling when shifting the shuttle lever while on a slope : Stop completely by using the brake and by depressing the clutch pedal. Start off after selecting shuttle direction by releasing the clutch pedal.</p>

1AGAIBDAP039A

(2) Part No. TA040-4965-2 [M8540, M9540]

	 DANGER
	<p>TO AVOID POSSIBLE INJURY OR DEATH FROM A MACHINE RUNAWAY.</p> <ol style="list-style-type: none"> 1. Do not start engine by shorting across starter terminals or bypassing the safety start switch. Machine may start in gear and move if normal starting circuitry is bypassed. 2. Start engine only from operator's seat with transmission and PTO OFF. Never start engine while standing on the ground.

1AGAIAZAP009A

(3) Part No. 6C150-4743-1 [Hydraulic shuttle model]

 WARNING	<p>BEFORE DISMOUNTING TRACTOR:</p> <ol style="list-style-type: none"> 1. ALWAYS SET PARKING BRAKE. Leaving transmission in gear with the engine stopped will not prevent tractor from rolling. 2. PARK ON LEVEL GROUND WHENEVER POSSIBLE. If parking on a slope, position tractor across the slope. 3. LOWER ALL IMPLEMENTS TO THE GROUND. 4. STOP THE ENGINE.
	

1AGAIBDAP040A

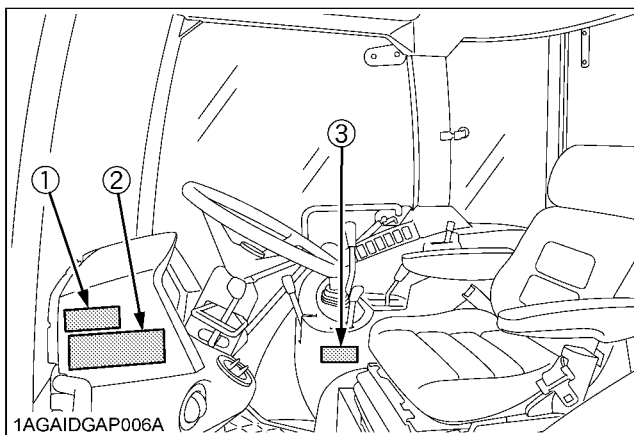

1AGAI DGAP006A

1AGAI DGAP072B

(1) Part No. 3F240-9836-2

⚠ CAUTION**TO AVOID PERSONAL INJURY:**

1. Read and understand the operator's manual before operation.
2. Before starting the engine, make sure that everyone is at a safe distance from tractor and the PTO is off.
3. Do not allow passengers on the tractor at any time.
4. Before allowing other people to use the tractor, have them read the operator's manual.
5. Check the tightness of nuts and bolts regularly.
6. Keep all shields in place and stay away from all moving parts.
7. Lock the two brake pedals together before driving on the road.
8. Slow down for turns, or rough roads, or when applying individual brakes.
9. On public roads use SMV emblem and hazard lights, if required by local traffic and safety regulations.
10. Pull only from the drawbar.
11. Before dismounting, lower the implement to the ground, set the parking brake, stop the engine and remove the key.
12. Securely support tractor and implements before working underneath.

1AGAICHAP113A

(2) Part No. TA040-4902-1

⚠ WARNING

TO AVOID INJURY OR DEATH FROM ROLL-OVER:
Always use seat belt when driving.

1AGAMAOAP078A

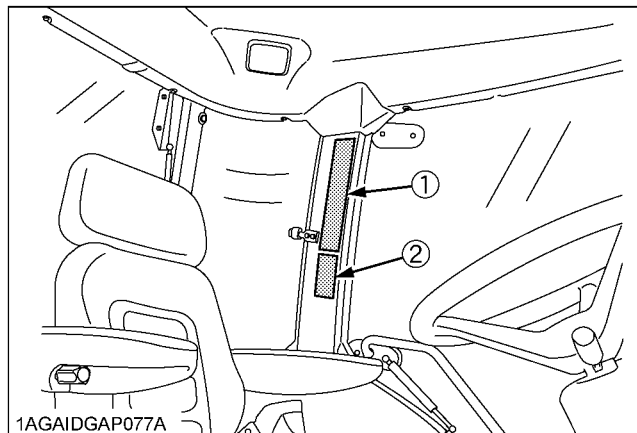

1AGAIDGAP077A

1AGAIDGAP071A

(1) Part No. 3P305-9856-1



1AGAICVAP046E

(2) Part No. TA040-4935-1



1AGAIAZAP056A

(3) Part No. TA040-4959-3

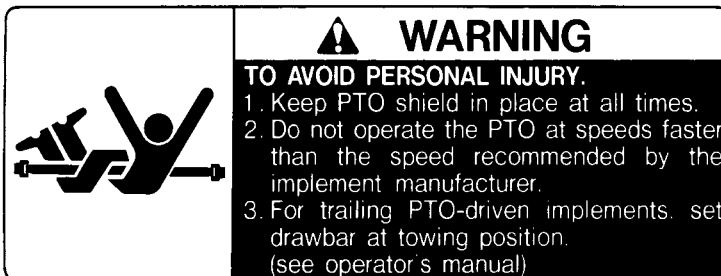

1AGAIAZAP116A

(4) Part No. 3F240-9819-1

[With Dual Speed model]

Do not stand by IMPLEMENT or between implement and tractor while operating remote hitch switch.

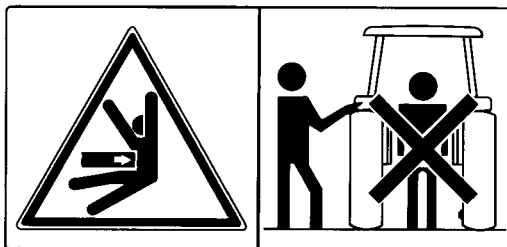

1AGAIBIAP1770

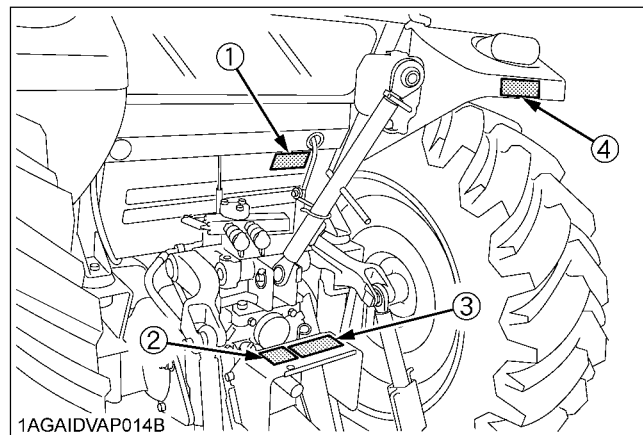

1AGAI DVAP014B

1AGAI DVAP015B

8. CARE OF DANGER, WARNING AND CAUTION LABELS

1. Keep danger, warning and caution labels clean and free from obstructing material.
2. Clean danger, warning and caution labels with soap and water, dry with a soft cloth.
3. Replace damaged or missing danger, warning and caution labels with new labels from your local KUBOTA Dealer.
4. If a component with danger, warning and caution label(s) affixed is replaced with new part, make sure new label(s) is (are) attached in the same location(s) as the replaced component.
5. Mount new danger, warning and caution labels by applying on a clean dry surface and pressing any bubbles to outside edge.

SPECIFICATIONS

SPECIFICATION TABLE

Model			M6040	M7040		M8540	M9540
			4WD	2WD	4WD	4WD	4WD
Engine	Model		V3307-DI			V3800-DI-T [V3800-DI-TE3]	
	Type		Direct Injection, liquid cooled 4 cylinder diesel				
	Number of cylinders		4				
	Total displacement	cm ³	3331			3769	
	Bore and stroke	mm	94 x 120			100 x 120	
	Rated speed	rpm	2600				
	Net power *1	kW	46.2	50.7	62.6	70.8	
	PTO power *1 (factory observed)	kW	41.0	46.2	56.0	62.7	
	Maximum torque	N-m / rpm	213 / 1300 to 1500	232 / 1300 to 1500	283 / 1400 to 1600	316 / 1400 to 1600 [314 / 1500 to 1700]	
	Battery capacity		12V, RC: 160 min, CCA 900A				
	Fuel		Diesel fuel No.1 (below-10 °C), Diesel fuel No.2 (above-10 °C)				
	Fuel tank capacity	L	90			110	
	Engine oil capacity	L	11			10.7	
Coolant capacity	L	8			9.0		
Dimensions	Overall length		mm	3505	3625	3505	3760 [3955]
	Overall width (minimum tread)		mm	1860			2010
	Overall height		mm	2555	2565		2570 [2650]
	Wheel base		mm	2110	2145	2110	2250
	Tread	Front	mm	1420, 1440, 1520	1420 to 1820	1420, 1440, 1520	1540, 1560, 1600 [1540, 1560, 1660]
		Rear	mm	1420 to 1720			1540 to 1940 [1498, 1598, 1698, 1798, 1898]
	Minimum ground clearance		mm	430 (Fuel tank stay)	440 (Fuel tank stay)		450 (Drawbar bracket)
Weight		kg	2430	2380	2440	2800	

2 SPECIFICATIONS

Model			M6040	M7040		M8540	M9540	
			4WD	2WD	4WD	4WD	4WD	
Traveling system	Standard tire size	Front tires	9.5-24	7.5-16	9.5-24	12.4-24 [360/70R24]		
		Rear tires *2	16.9-28	16.9-30		18.4-30 [480/70R34]		
	Clutch		Dry single plate / Multiple wet disks [Hydraulic multiple wet disks]					
	Steering		Hydraulic Power Steering					
	Braking system		Multiple wet disks mechanical			Hydraulic wet disks		
	Differential		Bevel gears with differential lock (Rear)					
Hydraulic unit	Hydraulic control system		Position, draft (top link sensing) & mix control					
	Pump capacity	L / min	41.6			64.3		
	Three point hitch		Category 1 and 2			Category 2		
	Max. lifting force	At lifting points *3	kg	1900 At lower link end with links horizontal			2500, 3900 with hydraulic High Capacity Lift Cylinders	
		24 in. behind lifting point	kg	1500			2100, 3300 with hydraulic High Capacity Lift Cylinders	
	Remote hydraulic control		2 standard (3rd & flow control valve optional)					
	System pressure	MPa (kgf/cm ²)	19.1 (195)			19.6 (200)		
	Traction system		Swinging drawbar, adjustable in direction					
PTO	Live PTO (Independent)	Direction of turning		Clockwise, viewed from tractor rear				
		PTO/ Engine speed	rpm	540 / 2160 540E / 1825			540 / 2035 540E / 1519	

The company reserves the right to change the specifications without notice.

NOTE: *1 Manufacturer's estimate

*2 Cast iron disks available for wheels.

*3 At lower link end with links horizontal.

A parenthesis [] shows a M9540 DUAL SPEED model.

TRAVELING SPEEDS

(At rated engine rpm)

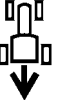
Model			M6040	M7040	M8540 / M9540	M9540	
Tire size (Rear)			16.9-28	16.9-30	18.4-30	480/70R34	
Transmission type			without Dual speed			with Dual speed	
						Hi	Lo
Shuttle shift lever	Range gear shift lever	Main gear shift lever	km/h	km/h	km/h	km/h	km/h
Forward 	CREEP	1	0.34	0.35	0.42	0.46	0.39
		2	0.48	0.50	0.54	0.59	0.50
		3	0.64	0.67	0.71	0.78	0.65
		4	1.0	1.1	0.91	0.99	0.84
		5	---	---	1.12	1.23	1.04
		6	---	---	1.35	1.48	1.25
	L	1	2.4	2.5	2.6	3.0	2.5
		2	3.4	3.5	3.4	3.8	3.2
		3	4.5	4.7	4.5	5.0	4.2
		4	7.4	7.7	5.7	6.4	5.4
		5	---	---	7.1	8.0	6.7
		6	---	---	8.5	9.6	8.1
	H	1	9.3	9.6	10.4	11.5	9.6
		2	13.1	13.6	13.4	14.7	12.4
		3	17.6	18.2	17.7	19.4	16.3
		4	28.6	29.7	22.6	24.8	20.9
		5	---	---	28.0	30.8	25.9
		6	---	---	33.7	37.0	31.1
Reverse 	CREEP	1	0.34	0.36	0.42	0.46	0.39
		2	0.49	0.51	0.53	0.60	0.50
		3	0.65	0.68	0.70	0.79	0.66
		4	1.1	1.1	0.90	1.01	0.85
		5	---	---	1.11	1.25	1.05
		6	---	---	1.34	1.50	1.26
	L	1	2.4	2.5	2.6	3.0	2.5
		2	3.4	3.6	3.4	3.9	3.3
		3	4.6	4.8	4.4	5.1	4.3
		4	7.5	7.8	5.7	6.5	5.5
		5	---	---	7.0	8.1	6.8
		6	---	---	8.5	9.7	8.2
	H	1	9.4	9.7	10.4	11.6	9.8
		2	13.3	13.8	13.3	14.9	12.5
		3	17.8	18.5	17.5	19.6	16.5
		4	29.0	30.1	22.5	25.1	21.1
		5	---	---	27.8	31.1	26.2
		6	---	---	33.4	37.5	31.5

The company reserves the right to change the specifications without notice

INSTRUMENT PANEL AND CONTROLS

■ Instrument Panel, Switches and Hand Controls

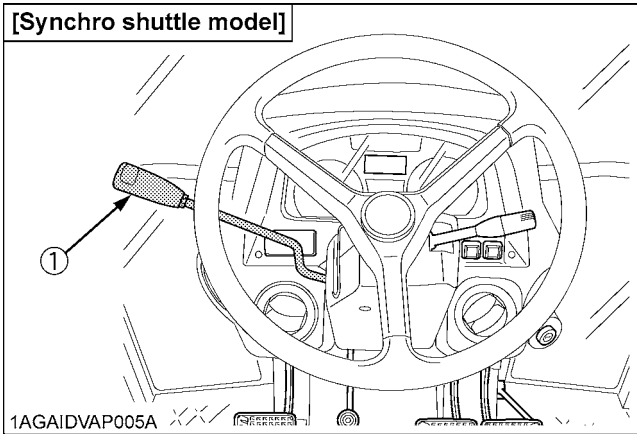
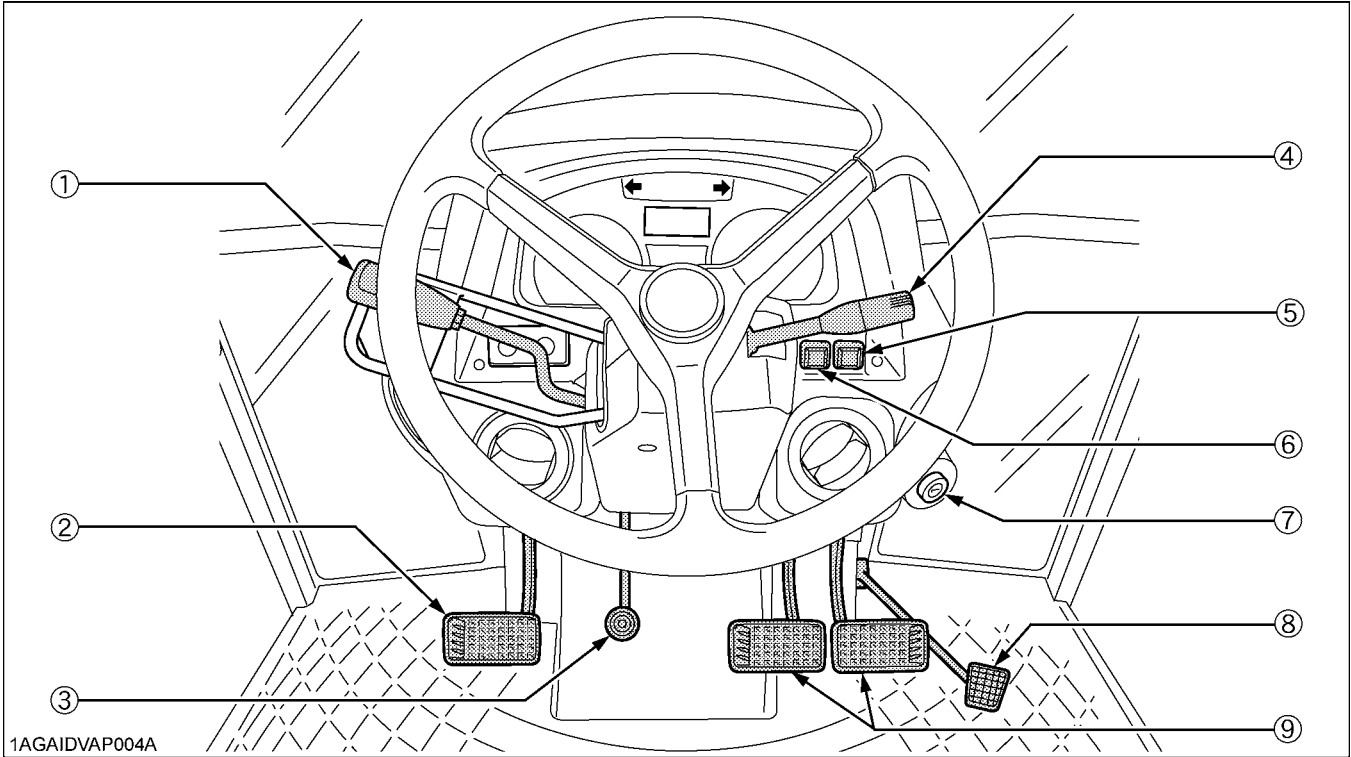

ILLUSTRATED CONTENTS

(1) Hydraulic-shuttle shift lever [Hydraulic shuttle model]	*
(1) Synchro-shuttle shift lever [Synchro shuttle model]	*
(2) Clutch pedal	*
(3) Tilt pedal	*
(4) Turn signal / Head light switch	11, 11
(5) Hazard light switch	11
(6) Horn button	*
(7) Key switch	*
(8) Foot throttle	*
(9) Brake pedal	*

* See operator's manual issued separately for the sister model. [M6040, M7040, M8540, M9540]

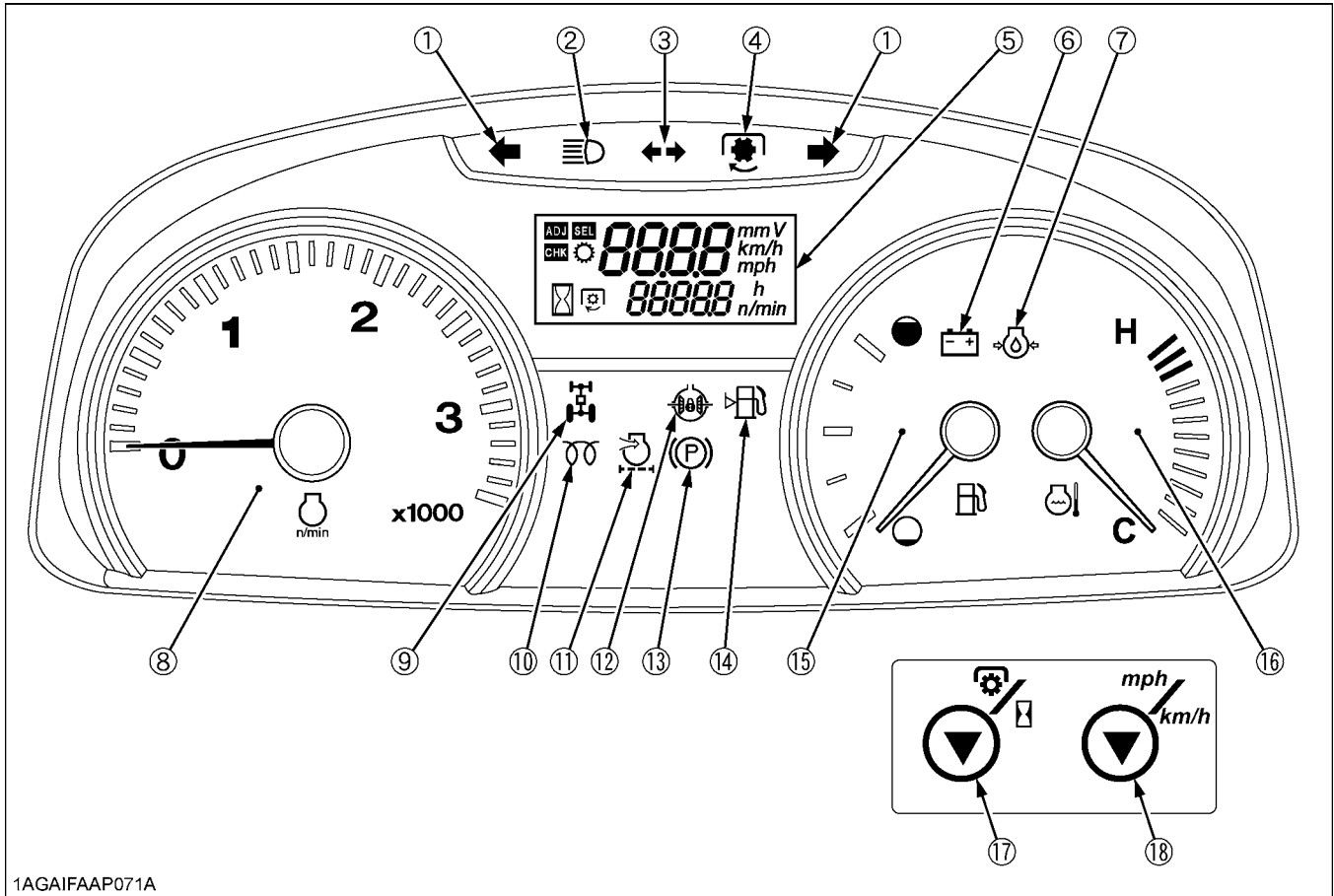

1AGAIFAAP071A

ILLUSTRATED CONTENTS

ILLUSTRATED CONTENTS

(1) Hazard / Turn signal indicator 11

(2) High beam indicator ---

(3) Trailer indicator 11

(4) PTO clutch indicator 15, 16

(5) Liquid crystal display *

(6) Electrical charge indicator *

(7) Engine oil pressure indicator *

(8) Tachometer *

(9) 4WD indicator *

(10) Heater indicator *

(11) Air cleaner indicator ---

(12) Rear wheel differential lock indicator *

(13) Parking brake indicator 13

(14) Fuel level indicator *

(15) Fuel gauge *

(16) Coolant temperature gauge *

(17) PTO / Hour meter select switch *

(18) Travel speed select switch *

NOTE :

- Only the M9540 dual speed model is equipped with an indicator (2) (3) (11) (12) and (13).
- Air cleaner indicator (11)
If the air cleaner clogged, the warning lamp in the Easy Checker(TM) will come on.
If this should happen during operation, clean the air cleaner element.
(See "Cleaning Air Cleaner Primary Element" in "EVERY 100 HOURS" in "PERIODIC SERVICE" section.)

■ Foot and Hand Controls

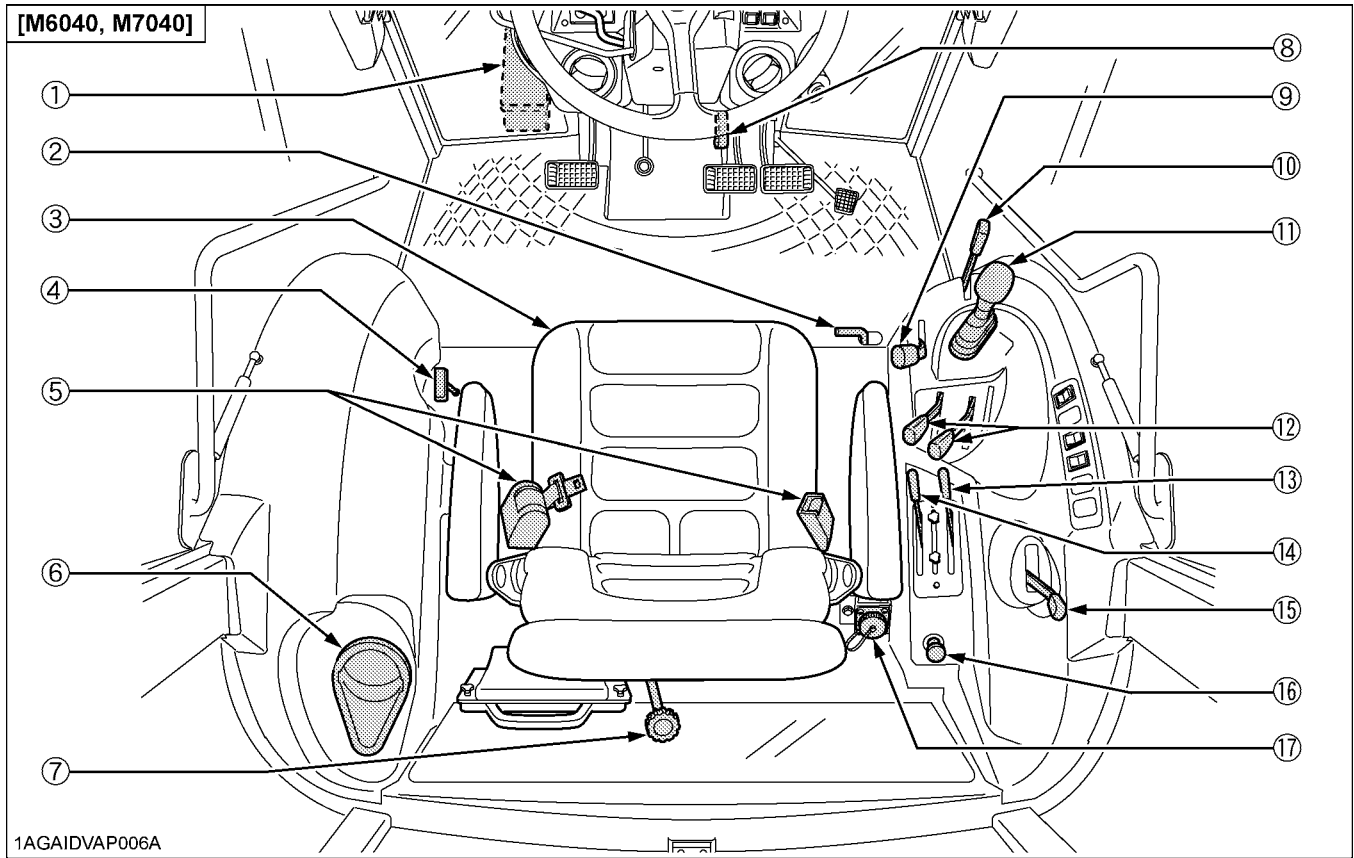

1AGAIDVAP006A

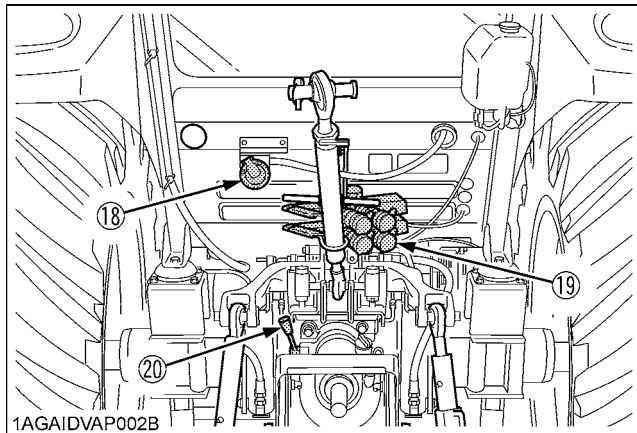

1AGAIDVAP002B

ILLUSTRATED CONTENTS

(1) Tool box	--
(2) Differential lock pedal	*
(3) Operator's seat	*
(4) Front wheel drive lever	*
(5) Seat belt	*
(6) Cup holder	--
(7) 3-Point hitch lowering speed knob	*
(8) Parking brake lever	*
(9) Hand throttle lever	*
(10) Range gear shift lever	*
(11) Main gear shift lever	*
(12) Remote control valve lever	20
(13) Position control lever	*
(14) Draft control lever	*
(15) PTO clutch control lever	15
(16) Cigarette lighter	*
(17) Electrical outlet	*
(18) Trailer electrical outlet	14
(19) Remote control valve coupler	*
(20) PTO gear shift lever	15

◆ without Dual Speed model

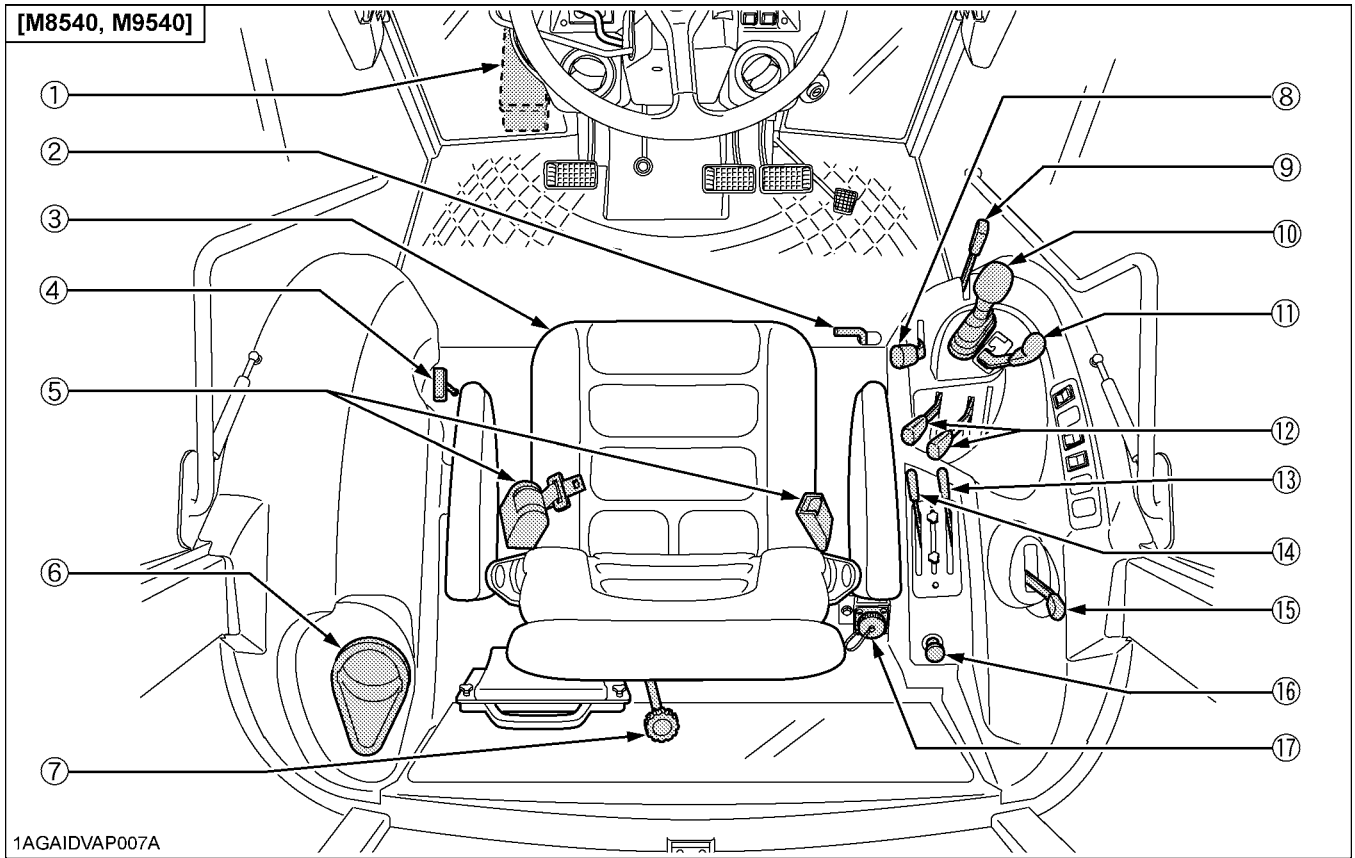

1AGAIDVAP007A

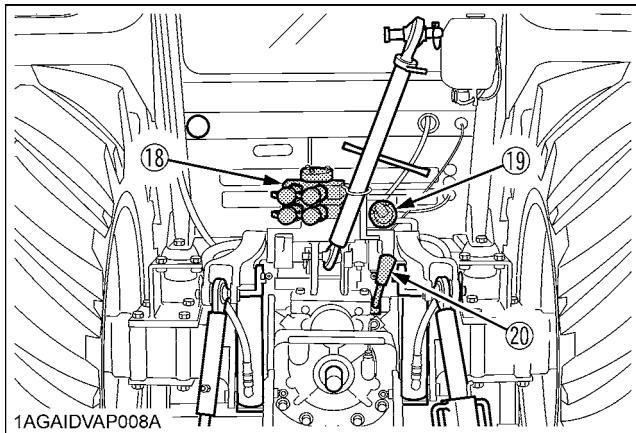

1AGAIDVAP008A

ILLUSTRATED CONTENTS

(1) Tool box	--
(2) Differential lock pedal	*
(3) Operator's seat	*
(4) Front wheel drive lever	*
(5) Seat belt	*
(6) Cup holder	--
(7) 3-Point hitch lowering speed knob	*
(8) Hand throttle lever	*
(9) Range gear shift lever	*
(10) Main gear shift lever	*
(11) Parking brake lever	*
(12) Remote control valve lever	20
(13) Position control lever	*
(14) Draft control lever	*
(15) PTO clutch control lever	15
(16) Cigarette lighter	*
(17) Electrical outlet	*
(18) Remote control valve coupler	*
(19) Trailer electrical outlet	14
(20) PTO gear shift lever	15

◆ with Dual Speed model

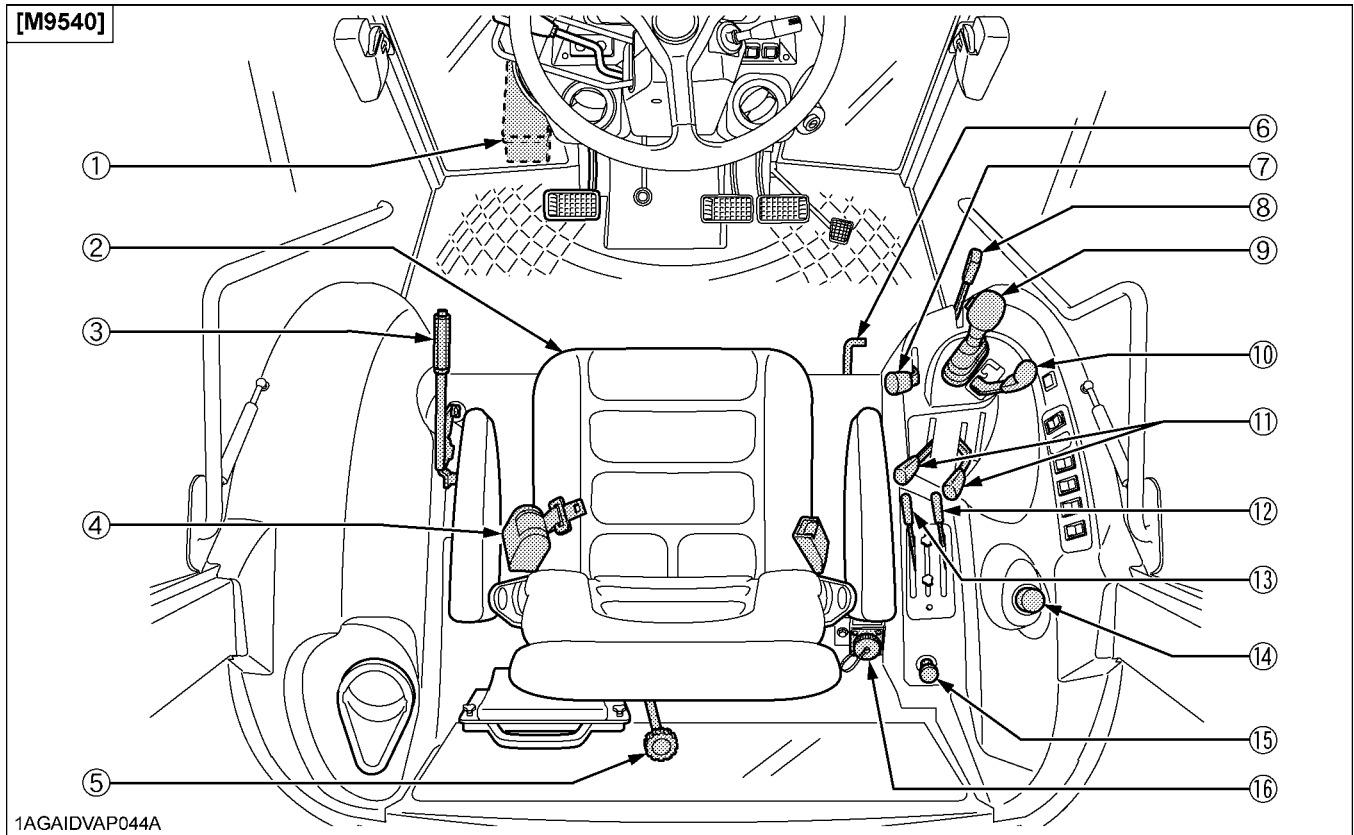

1AGAIDVAP044A

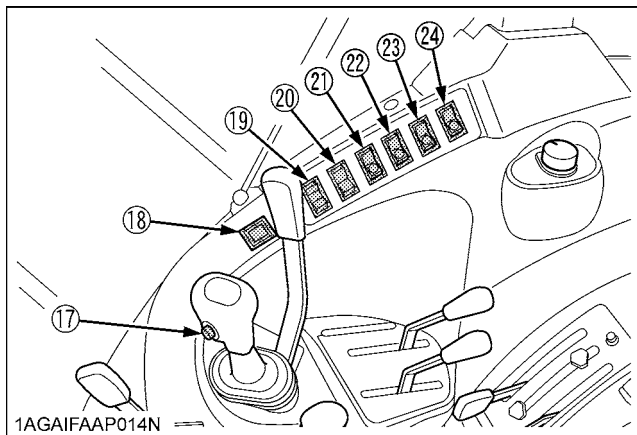

1AGAIFAAP014N

ILLUSTRATED CONTENTS

(1) Tool box	---
(2) Operator's seat	10
(3) Parking brake lever	13
(4) Seat belt	*
(5) 3-Point hitch lowering speed knob	*
(6) Differential lock pedal	*

ILLUSTRATED CONTENTS

(7) Hand throttle lever	*
(8) Range gear shift lever	*
(9) Main gear shift lever	*
(10) Gear locked parking lever	13
(11) Remote control valve lever	20
(12) Position control lever	*
(13) Draft control lever	*
(14) PTO clutch control switch	16
(15) Cigarette lighter	*
(16) Electrical outlet	*
(17) Dual speed shift switch	*
(18) Dual speed indicator	*
(19) Front wiper / Washer switch	*
(20) Rear wiper / Washer switch	*
(21) Front wheel drive switch (4WD)	*
(22) Front work light switch	*
(23) Rear work light switch	*
(24) Beacon light switch	*

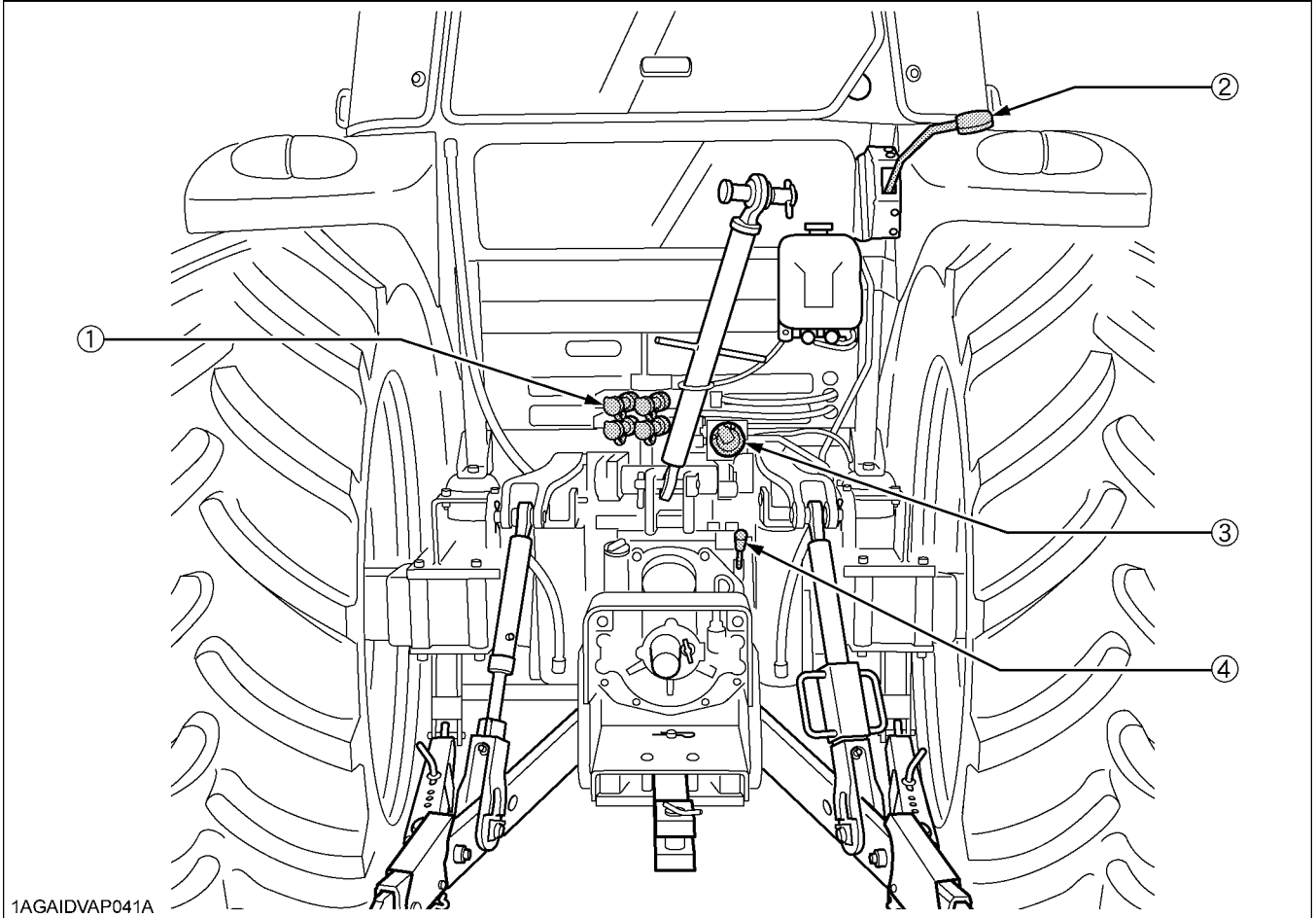

ILLUSTRATED CONTENTS

(1) Remote control valve coupler	*
(2) Remote hitch Up / Down lever	18
(3) Trailer electrical outlet	14
(4) PTO gear shift lever	15

OPERATING THE TRACTOR

STARTING

[With Dual Speed model]

Operator's Seat



CAUTION

To avoid personal injury:

- Make adjustments to the seat only while the tractor is stopped.
- Make sure that the seat is completely secured after each adjustment.
- Do not allow any person other than the operator to ride on the tractor.

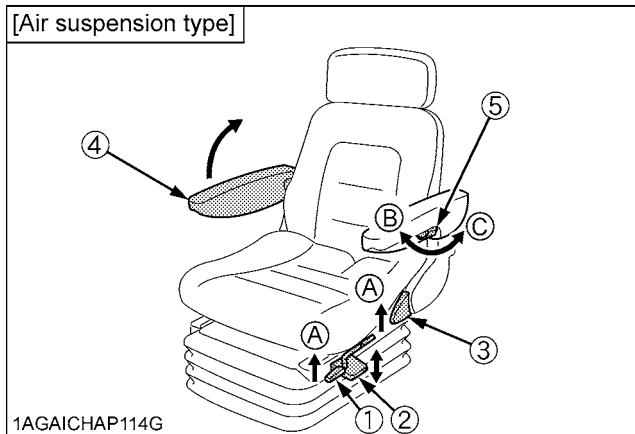

- | | |
|----------------------------------|-------------------------|
| (1) Travel adjust lever | (A) "UNLOCK" |
| (2) Weight / Height adjust lever | (B) "TO INCREASE ANGLE" |
| (3) Backrest tilt adjust lever | (C) "TO DECREASE ANGLE" |
| (4) Arm rest | |
| (5) Arm rest angle adjust knob | |

◆ Travel adjustment

Unlock the travel adjust lever and slide the seat backward or forward, as required. The seat will lock in position when the lever is released.

◆ Weight and Height adjustment

Turn on the key switch. The seat should be adjusted for the operator's weight by briefly pulling up or pushing down the weight / height adjust lever with the tractor in a stationary position and the operator sitting on the seat. The seat can be adjusted in its adjustable range.

NOTE :

- If the seat is lowered below the adjustable range, it automatically comes up to the lower limit of the adjustable range just when the weight / height adjust lever is released.
- When turning on the key switch, the seat may slightly move up depending on a preset seat position (height).

IMPORTANT :

- In order to avoid damage of the seat, do not operate the weight / height adjust lever for more than 1 minute.

◆ Tilt adjustment

Pull the backrest tilt adjust lever and tilt the backrest to the desired position.

◆ Arm rest

Armrest may be set at upright position if desired.

◆ Arm rest angle adjustment

Turn the arm rest angle adjust knob to the desired angle.

IMPORTANT :

- After adjusting the operator's seat, be sure to check to see that the seat is properly locked,

■ Light Switch

Turn the light switch clockwise, and the following lights are activated on the switch position.

- OFF..... Head lights OFF.
- ☉..... Head lights dimmed, low beam.
- ☉..... Head lights ON, high beam.

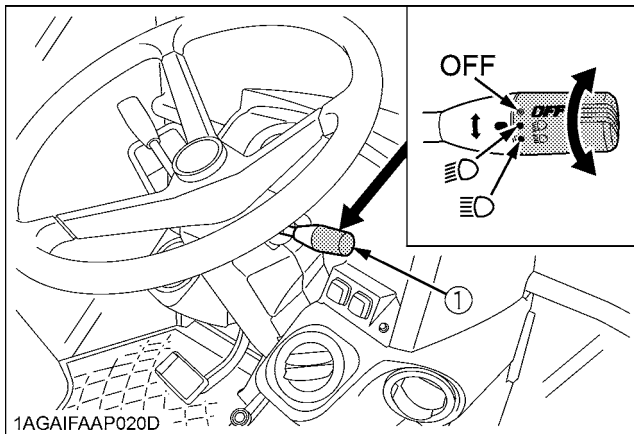

(1) Head light switch

■ Turn Signal / Hazard Light Switch

◆ Turn Signal Light Switch

To indicate a right turn, turn the turn signal light switch clockwise. To indicate a left turn, turn the turn signal light switch counter-clockwise. The corresponding right and left turn signal lights and indicator on the instrument panel will flash. Turn signal is active when key switch is in the "ON" position.

NOTE :

- Be sure to return switch to center position after turning.

◆ Hazard Light Switch

When hazard light switch is pushed, the hazard lights flash along with the indicator on the instrument panel. Press the hazard light switch again to turn off the light.

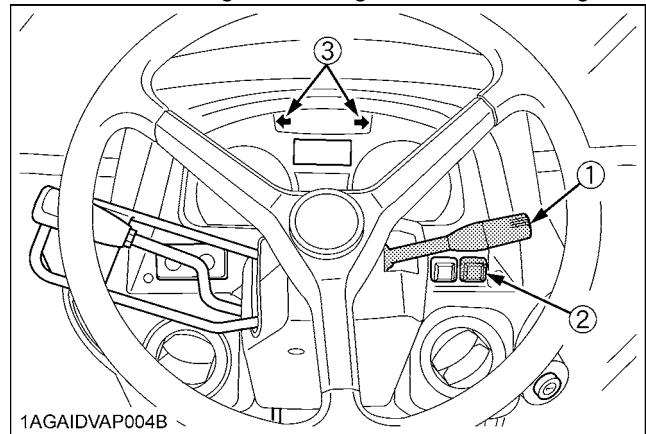

- (1) Turn signal light switch
- (2) Hazard light switch
- (3) Hazard / Turn signal indicator

■ With Trailer Connector

When you operate the turn signal light switch with the trailer power connector connected, the trailer indicator in the instrumental panel also starts flashing along with the turn signal indicator.

PTO RPM / TRAVEL SPEED MONITOR

■ PTO Speed Display Mode Switching

The PTO speed display mode has been factory-set as table below. Do not attempt to change the code. Otherwise the correct PTO speed will not be displayed in the LCD monitor.

(NOTE: The current code can be checked in the following procedure.)

◆ Switching procedure

- ① While pressing the PTO/Hour meter select switch, turn the key switch to "ON" position.

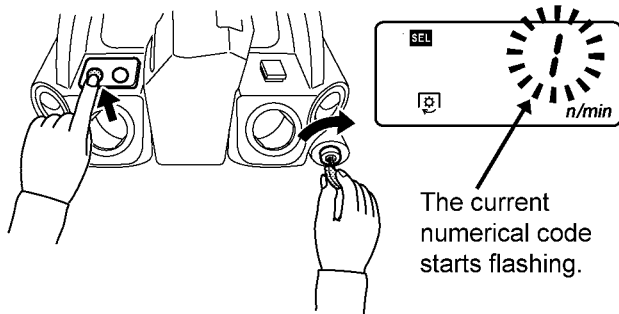

- ② Each time the PTO/Hour meter select switch is pressed, the code changes in the order of [1]→[2]→[1], [1]→[2]→[3]→[4]→[5]→[1]. Select the appropriate code according to the table below.

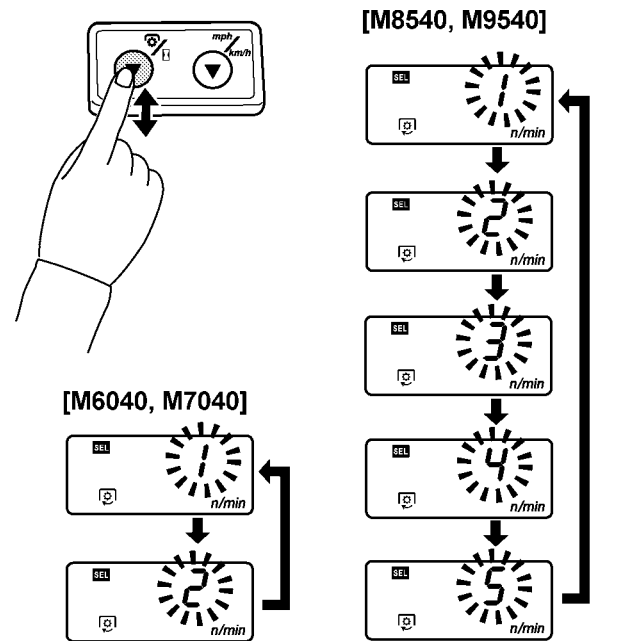

1AGAIDVAP009A

- ③ Press and hold the PTO/Hour meter select switch longer than 2 seconds. The setting is put in memory, and the LCD monitor goes back to the PTO speed display mode.

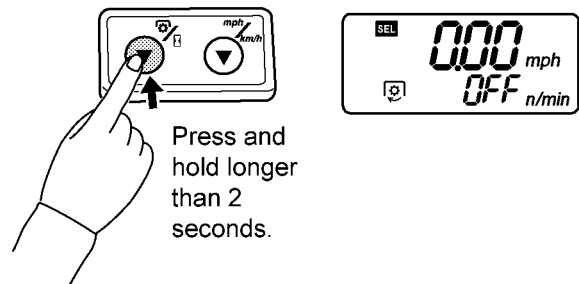

NOTE:

- The setting will be cancelled if the key switch is turned OFF halfway in the procedure.

Model	Numerical code	PTO speed (rpm)
M6040 M7040	1	540 / 540E (Oceania models)
M8540 M9540	4	

- It is the ban selection except the above mentioned code number.

PARKING

[With Dual Speed model]

When parking the tractor, set the both parking levers.



CAUTION

To avoid personal injury:
BEFORE DISMOUNTING TRACTOR

- ALWAYS SET PARKING BRAKE AND LOWER ALL IMPLEMENTS TO THE GROUND.
Leaving transmission in gear with the engine stopped will not prevent the tractor from accidental rolling.
- STOP THE ENGINE AND REMOVE THE KEY.

■ Parking Brake Lever

Pull the parking brake lever up to park.

The parking brake indicator light on the Easy Checker(TM) will come on while the parking brake is set.

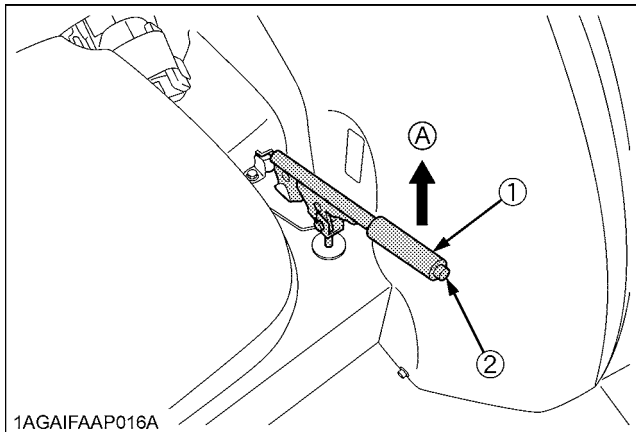

1AGAIFAAP016A

- (1) Parking brake lever (A) "PULL"
(2) Release button

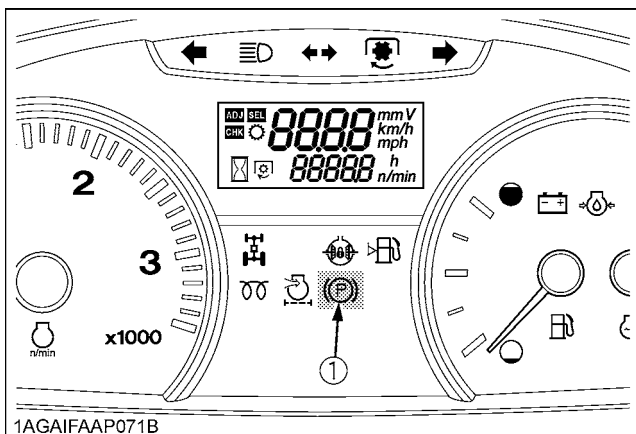

1AGAIFAAP071B

- (1) Parking brake indicator light

IMPORTANT :

- If the tractor is operated with the parking brake set, the parking brake will be damaged.

■ Gear Locked Parking Lever

1. To set the gear locked parking lever;
 - (1) Depress the brake pedals.
 - (2) Place the main gear shift lever in neutral position.
 - (3) Push the gear locked parking lever to parking position.
2. To release the gear locked parking lever, depress the brake pedals and shift the lever to transport position.

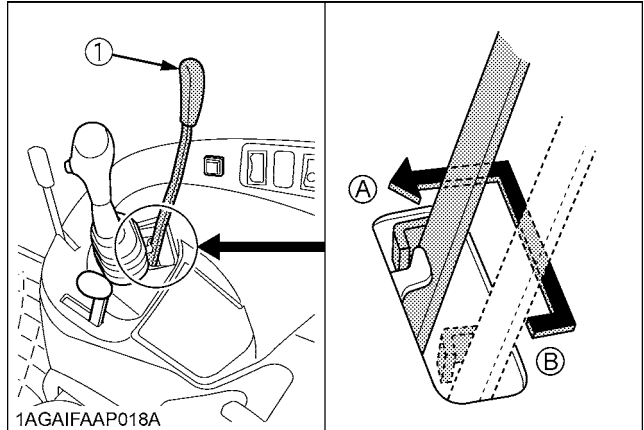

- (1) Gear locked parking lever (A) "PARKING POSITION"
(B) "TRANSPORT POSITION"

IMPORTANT :

- Bring the tractor to a complete stop before applying the gear locked parking lever.
- The gear locked parking lever can be turned ON and OFF only when the main gear shift lever is at the neutral position.

NOTE :

- In moving the gear locked parking lever, you may feel it heavy some time or light other time. This is not a trouble, however.

OPERATING TECHNIQUES

Trailer Electrical Outlet

A trailer electrical outlet is supplied for use with trailer or implement.

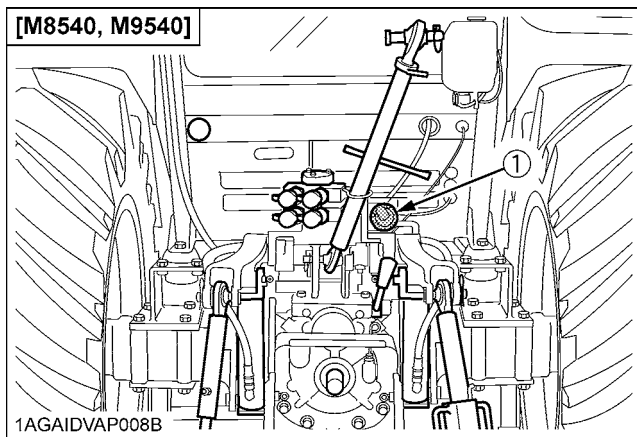
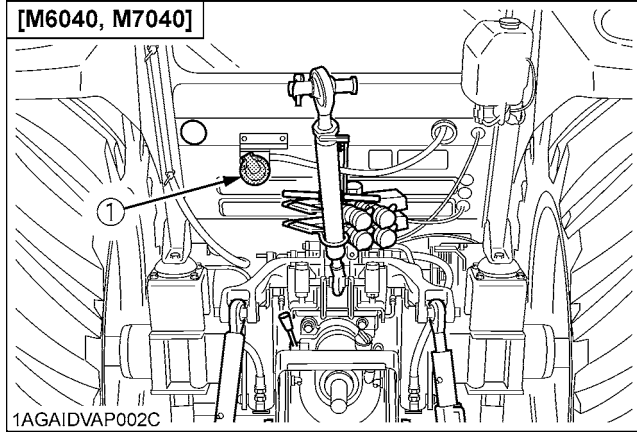

(1) Trailer electrical outlet

Function of each terminals in trailer electrical outlet

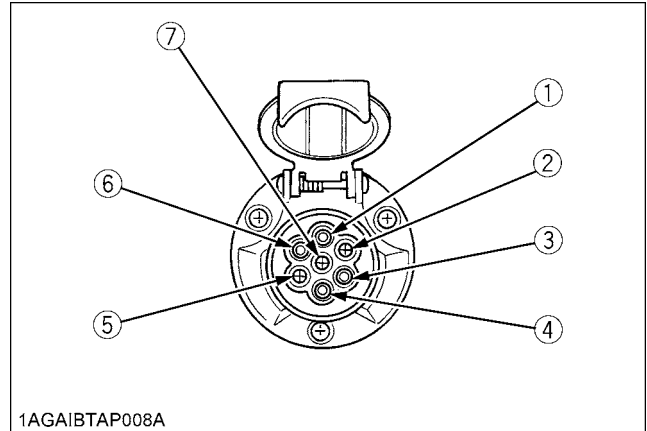

Terminal	Function
(1)	Turn signal light (LH)
(2)	---
(3)	Ground
(4)	Turn signal light (RH)
(5)	Tail light Sidemarker light Parking light
(6)	Brake stop light
(7)	Number plate light

PTO

PTO OPERATION



CAUTION

To avoid personal injury:

- Disengage PTO, stop engine, and allow all rotating components to come to a complete stop before connecting, disconnecting, adjusting, or cleaning any PTO driven equipment.

PTO Gear Shift Lever



WARNING

To avoid personal injury:

- Be sure to observe the PTO shaft speed prescribed for the individual implements. It is extremely dangerous to run an implement at high speed that is meant to be operated at low speed. Use only when this higher rpm is specifically recommended by the implement manufacturer.

The PTO gear shift lever can be set to either 540 rpm or 540E rpm positions.

Move this lever to either position with the PTO clutch control switch or lever set to "OFF".

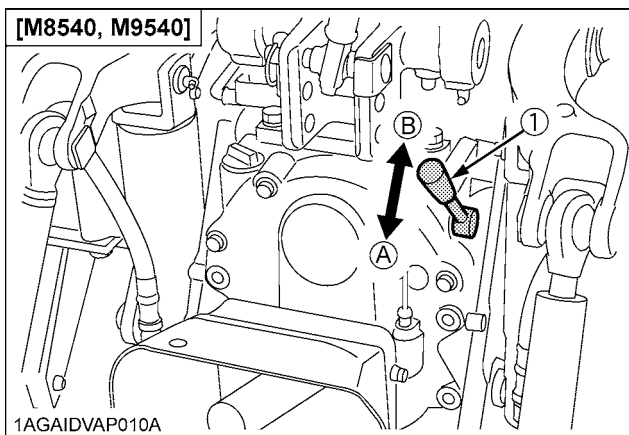
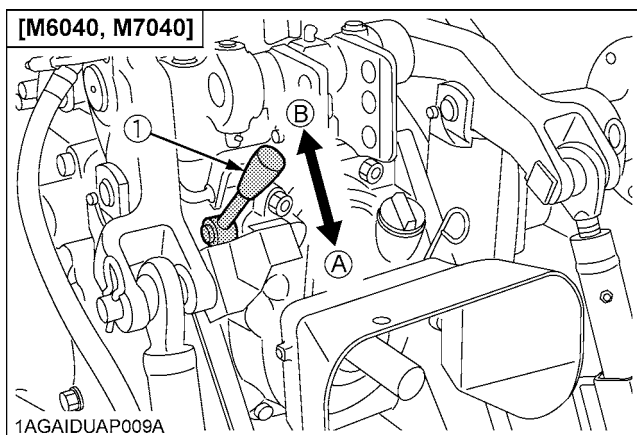

(1) PTO gear shift lever

(A) 540 rpm

(B) 540E rpm

NOTE :

- When light load, select the "540E" position for economical operation.

PTO Clutch Control Lever

[Without Dual Speed model]

The PTO clutch control lever engages or disengages the PTO clutch which gives the PTO independent control. Shift the lever to "ON" to engage the PTO clutch. Shift the lever to "OFF" to disengage the PTO clutch.

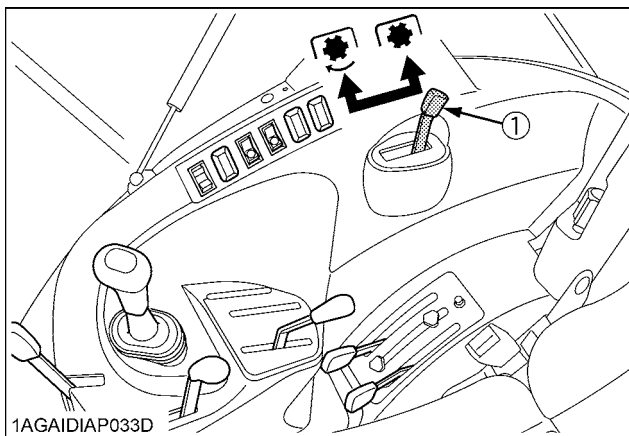

(1) PTO clutch control lever

☑ "ON" (Engaged)

☒ "OFF" (Disengaged)

IMPORTANT :

- To avoid shock loads to the PTO, reduce engine speed when engaging the PTO, then open the throttle to the recommended speed.
- To avoid damage of PTO clutch and implement, shift the PTO clutch control lever slowly, when engaging the PTO clutch. Do not keep the PTO clutch control lever half way.

Tractor model	(A) 540	(B) 540E
	PTO / Engine speed rpm	
M6040 M7040	540 / 2160	540 / 1825
M8540 M9540	540 / 2035	540 / 1519

NOTE :

- Tractor engine will not start if PTO clutch control lever is in the engaged "ON" position.
- If the PTO system is engaged and you stand up from the seat, the warning buzzer will whistle for about 10 seconds after standing up.
This is because the tractor is equipped with "Operator Presence Control System".

◆ PTO Clutch Indicator

The PTO clutch indicator turns on while PTO clutch control lever is in "ON" (Engage) position.

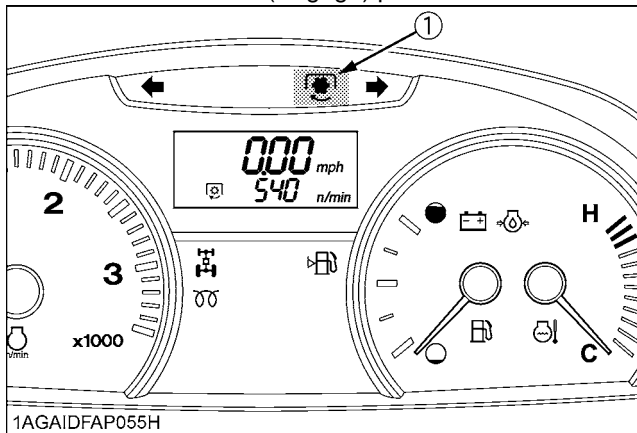

(1) PTO clutch indicator

■ PTO Clutch Control Switch

[With Dual Speed model]

The PTO clutch control switch engages or disengages the PTO clutch which gives the PTO independent control. Turn the switch to "ON" to engage the PTO clutch. Turn the switch to "OFF" to disengage the PTO clutch.

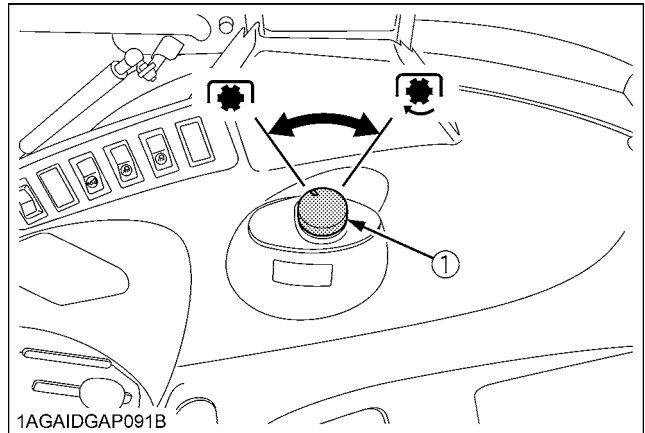

(1) PTO clutch control switch ☸ "ON" ☸ "OFF"

◆ PTO Clutch Control Switch

To turn ON

While pushing the switch, turn clockwise to the "☸" position and release your hand. (In the ON position, switch slightly rises itself.)

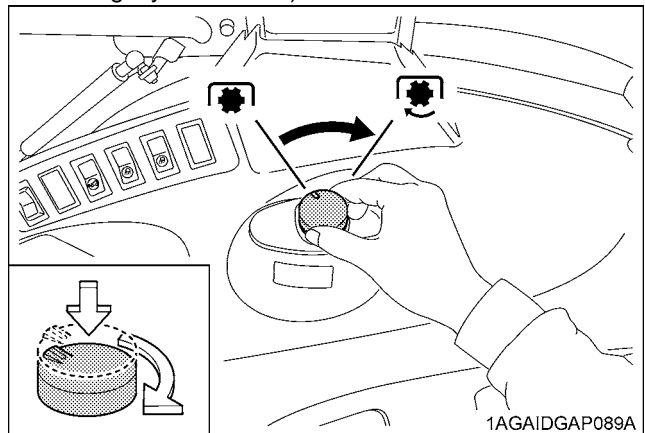

To Turn OFF

Tap on top of the switch, and the switch will return to the OFF position.

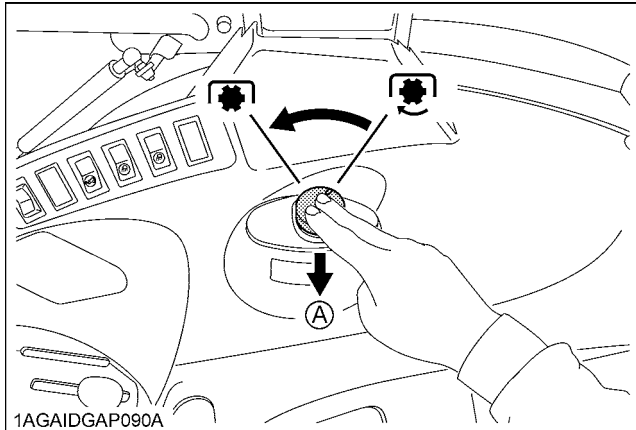

(A) "PUSH"

IMPORTANT :

- To avoid shock loads to the PTO, reduce engine speed when engaging the PTO, then open the throttle to the recommended speed.

NOTE :

- Tractor engine will not start if PTO clutch control switch is in the engaged "ON" position.
- If the PTO system is engaged and you stand up from the seat, the warning buzzer will whistle for about 10 seconds after standing up. This is because the tractor is equipped with "Operator Presence Control System".

◆ PTO Clutch Indicator

The PTO clutch indicator turns on while PTO clutch control switch is in "ON" (Engage) position.

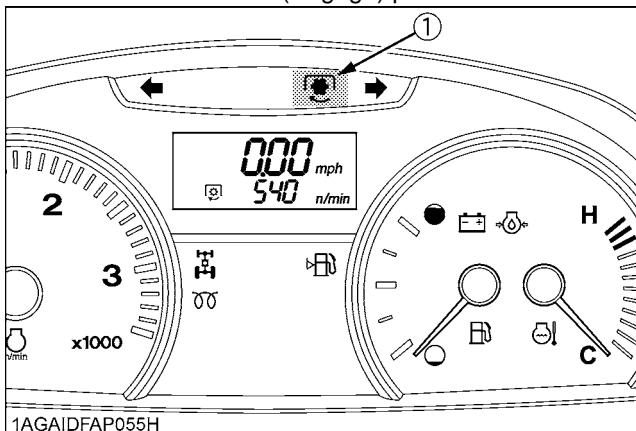

(1) PTO clutch indicator

■ LCD Monitor Message

1. The PTO rpm can be checked in the LCD monitor. (See "PTO RPM / TRAVEL SPEED MONITOR" in "OPERATING THE TRACTOR" section.)
2. When the PTO system gets engaged (ON), the indicator lights up.

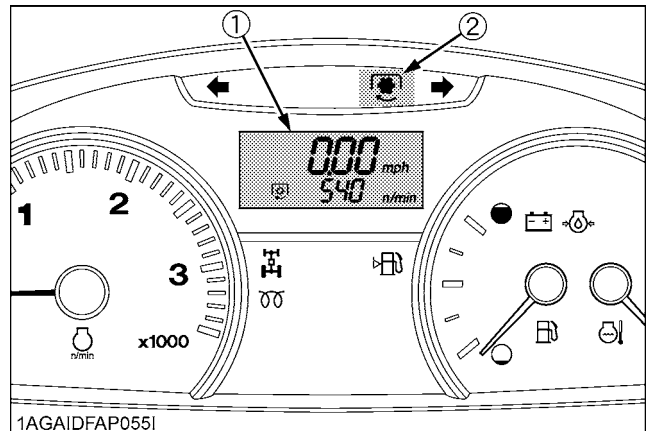

- (1) LCD monitor
(2) PTO clutch indicator

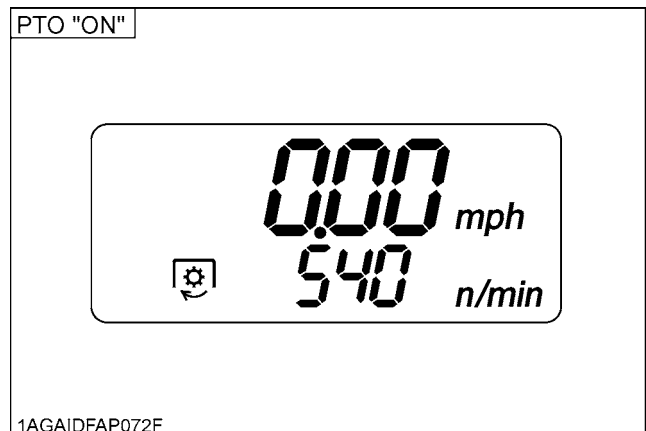

THREE-POINT HITCH & DRAWBAR

3-POINT HITCH

■ Remote Hitch UP / DOWN Lever
[With Dual Speed model]

CAUTION

To avoid personal injury:

- Do not use the Remote hitch up / down lever when the implement is attached on the 3-point hitch.

This lever is used to raise and lower the 3-point hitch for aligning the arm with the implement only.

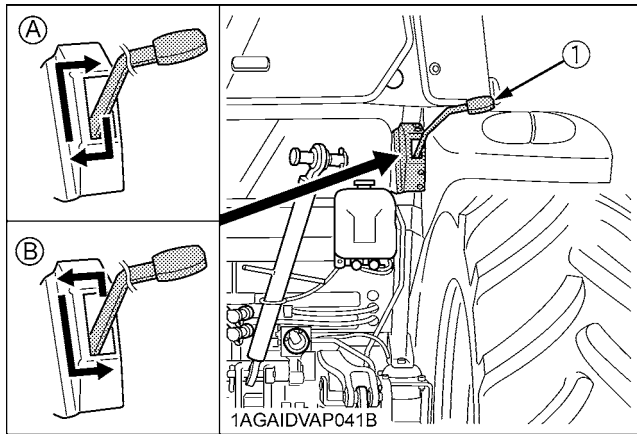

(1) Remote hitch up / down lever

(A) "UP"
(B) "DOWN"

DRAWBAR

WARNING

To avoid personal injury:

- Never pull from the top link, the rear axle or any point above the drawbar. Doing so could cause the tractor to tip over rearward causing personal injury or death.

■ Adjusting Drawbar Length

When towing an implement, it is recommended that the (A) hole in drawbar be utilized.

The drawbar load is specified in the "IMPLEMENT LIMITATIONS" section.

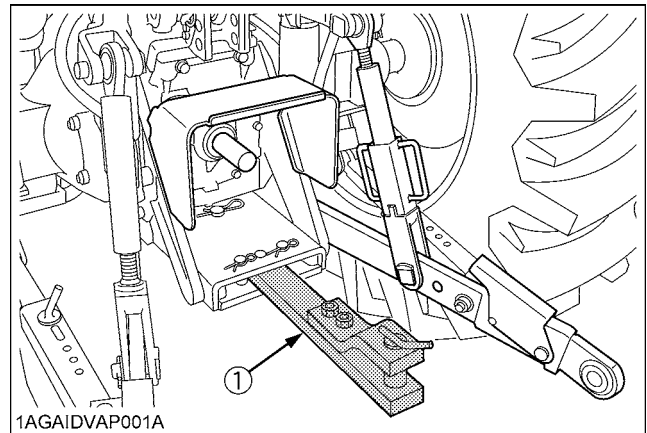

1AG AIDVAP001A

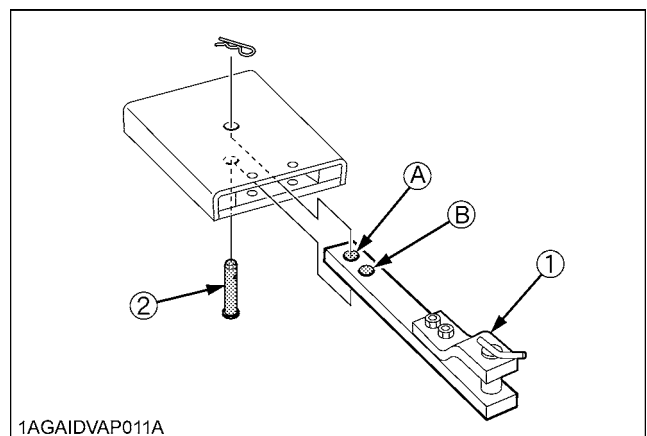

(1) Drawbar
(2) Pivot pin

Holes: (A), (B)

■ Swing Drawbar

The drawbar can be used in three different ways as illustrated below. Assemble it correctly with locating pins.

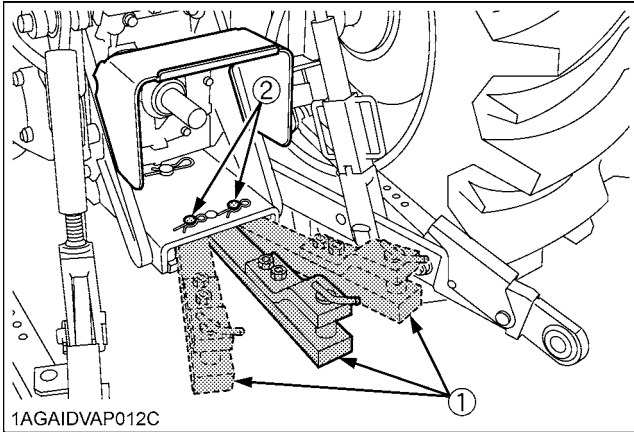

- (1) Drawbar
- (2) Locating pin

HYDRAULIC UNIT

REMOTE HYDRAULIC CONTROL SYSTEM

The hydraulic auxiliary control valves can be installed up to triple segments.

It is not possible to use triple segments with flow control valve.

Remote Control Valve

There are three types of remote valves available for these models.

- **Double acting valve with detents and self cancelling:**
This valve may be placed in the detent mode. The lever will stay in this position until the pressure reaches a predetermined level or a cylinder reaches the end of its stroke. Then it will automatically return to neutral.
- **Double acting valve with float position:**
This valve may be placed in the float mode with the control lever all the way forward. The cylinder is free to extend or retract, letting an implement such as a loader bucket follow the ground.
- **Single/double acting valve:**
This valve can be utilized as single or double acting valve by adjusting the auxiliary control valve selector knob located on the valve.
 - 1) Turn the auxiliary control valve selector knob clockwise all the way to utilize as single acting valve.
 - 2) Turn the auxiliary control valve selector knob anticlockwise all the way to utilize as double acting valve.

NOTE :

- This float valve can be attached as the second or third segment.

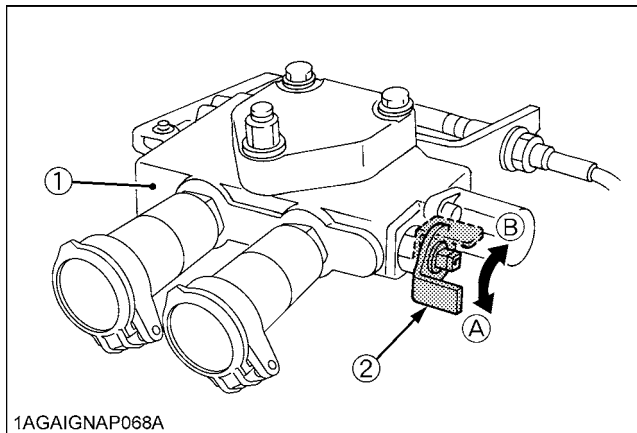

(1) Single / double acting valve
(2) Auxiliary control valve selector knob

(A) Double acting
(B) Single acting

Remote Control Valve Lever

The remote control valve lever directs pressurized oil flow to the implement hydraulic system.

[Without Dual Speed model]

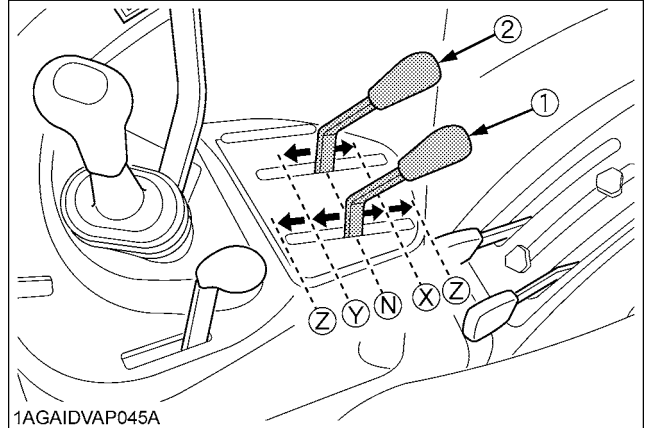

(1) Remote control valve lever with Double acting valve /
(2) Detents and self cancelling
Remote control valve lever with Single / Double acting valve

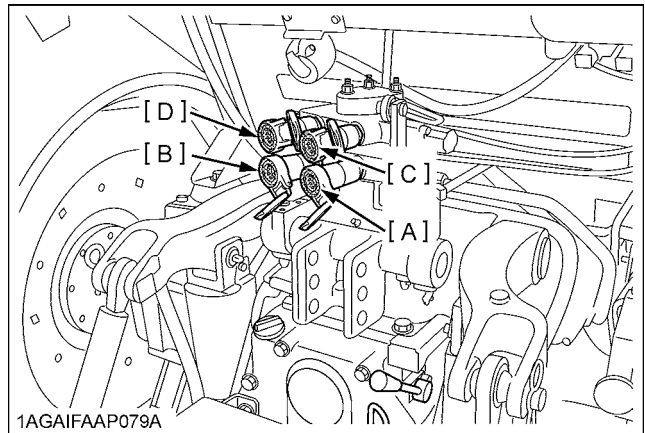

Pressure →
Returning ←

Lever (1)	Lever position			
	Z (detent)	Y	X	Z (detent)
Port	[A]	Out →		In ←
	[B]	In ←		Out →

		Double-acting		Single-acting	
Lever (2)		Y	X	Y	X
Port	[C]	Out →	In ←	-	-
	[D]	In ←	Out →	In ←	Out →

[With Dual Speed model]

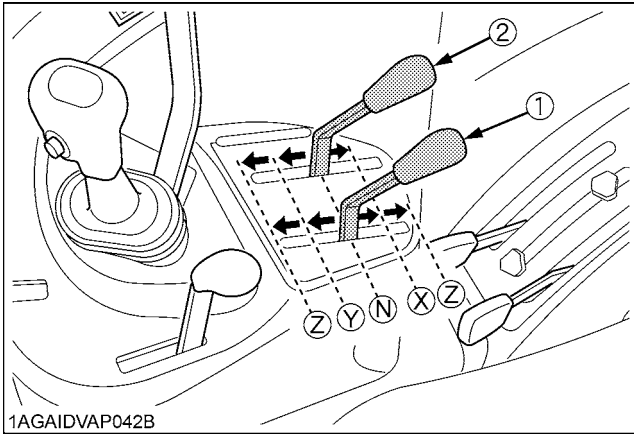

1AGAIDVAP042B

(1) Remote control valve lever with Double acting valve /
 (2) Detents and self cancelling
 Remote control valve lever with Double acting valve /
 Float position

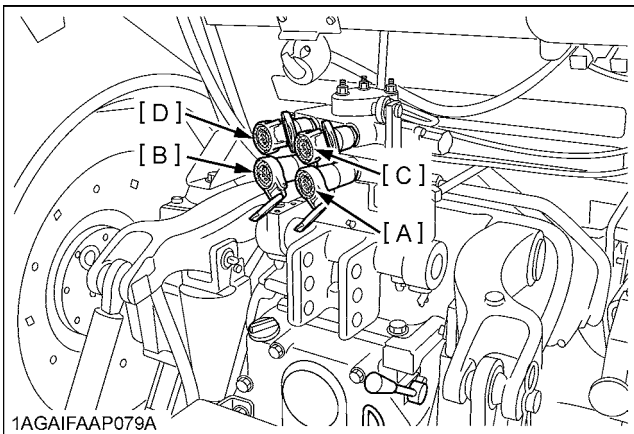

1AGAIFAAP079A

Pressure →
 Returning ←

Lever (1)		Lever position			
		Z (detent)	Y	X	Z (detent)
Port	[A]	Out →		In ←	
	[B]	In ←		Out →	

Lever (2)		Lever position		
		Z (detent)	Y	X
Port	[C]	In	Out →	In ←
	[D]	Out	In ←	Out →

IMPORTANT :

- Do not hold the lever in the "REARWARD" or "FORWARD" position once the remote cylinder has reached the end of the stroke, as this will cause oil to flow through the relief valve. Forcing oil through the relief valve for extended periods will overheat the oil.
- When using the tractor hydraulic system to power front loader, do not operate boom and bucket cylinders simultaneously.

NOTE :

- Connect the pressure of load side of implement cylinders to ports [B] or [D] which have built in load check valve to prevent leak down.
- To use the single-acting cylinder with the float valve, connect this cylinder to the [B] or [D] port. To extend a single-acting cylinder, pull the remote control valve lever rearward. To retract a cylinder, push it fully forward to the "FLOAT" position. Do not hold it in the "FORWARD" position, the transmission fluid may be overheat.

TIRES, WHEELS AND BALLAST

TIRES



WARNING

To avoid personal injury:

- Do not attempt to mount a tire on a rim. This should be done by a qualified person with the proper equipment.
- Always maintain the correct tire pressure. Do not inflate tires above the recommended pressure shown in the operator's manual.

IMPORTANT :

- Do not use tires other than those approved by KUBOTA.

NOTE :

- When optional different-diameter tires are fitted on the machine, the travel speed display mode must be changed. Otherwise the travel speed will not get correctly displayed. Such mode switching is also needed when the original tires are back on the machine.
(See "PTO RPM / TRAVEL SPEED MONITOR" in "OPERATING THE TRACTOR" section.)

■ Inflation Pressure

Though the tire pressure is factory-set to the prescribed level, it naturally drops slowly in the course of time. Thus, check it everyday and inflate as necessary.

	Tire sizes	Inflation Pressure
Front	6.50-16, 6PR	320 kPa (3.2 kgf/cm ²)
	7.50-16, 6PR	280 kPa (2.8 kgf/cm ²)
	9.5L-15, 6PR	220 kPa (2.2 kgf/cm ²)
	9.5-20, 6PR	200 kPa (2.0 kgf/cm ²)
	9.5-22, 6PR	200 kPa (2.0 kgf/cm ²)
	9.5-24, 6PR	180 kPa (1.8 kgf/cm ²)
	360/70R24	160 kPa (1.6 kgf/cm ²)
Rear	14.9-28, 6PR	140 kPa (1.4 kgf/cm ²)
	16.9-28, 6PR	120 kPa (1.2 kgf/cm ²)
	16.9-30, 6PR	120 kPa (1.2 kgf/cm ²)
	18.4-30, 6PR	120 kPa (1.2 kgf/cm ²)
	16.9-34, 6PR	120 kPa (1.2 kgf/cm ²)
	480/70R34	120 kPa (1.2 kgf/cm ²)

NOTE :

- Maintain the maximum pressure in front tires, if using a front loader or when equipped with a full load of front weights.

■ Dual Tires

Dual tires are not approved.

WHEEL ADJUSTMENT



CAUTION

To avoid personal injury:

- When working on slopes or when working with trailer, set the wheel tread as wide as practical for maximum stability.
- Support tractor securely on stands before removing a wheel.
- Do not work under any hydraulically supported devices. They can settle, suddenly leak down, or be accidentally lowered. If necessary to work under tractor or any machine elements for servicing or adjustment, securely support them with stands or suitable blocking beforehand.
- Never operate tractor with a loose rim, wheel, or axle.

■ Front Wheels (with four wheel drive)

Front tread width can be adjusted as shown with the standard equipped tires.

To change the tread width

1. Remove the wheel rim and disk mounting bolts.
2. Change the position of the rim and disk (right and left) to the desired position, and tighten the bolts.
3. Adjust the toe-in: [2 to 8mm]
See "Adjusting Toe-in" in "EVERY 200 HOURS" in "PERIODIC SERVICE" section.

IMPORTANT :

- Always attach wheels as shown in the drawing.
- If not attached as illustrated, transmission parts may be damaged.
- When re-fitting or adjusting a wheel, tighten the bolts to the following torques then recheck after driving the tractor 200m (200 yards) and thereafter according to service interval. (See "MAINTENANCE" section.)

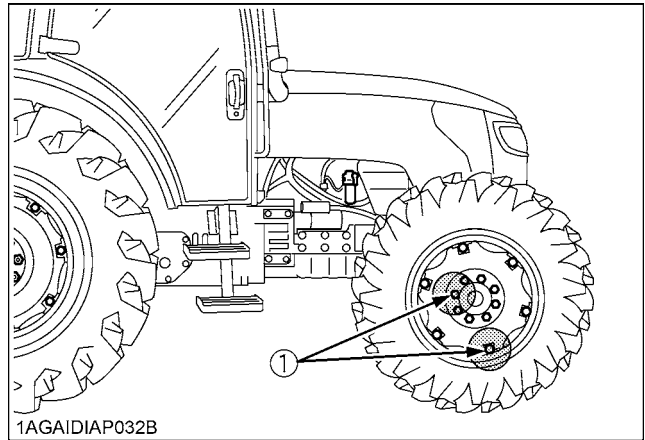

(1) 260 to 304 N-m (26.5 to 31 kgf-m)

NOTE :

- Wheels with beveled or tapered holes: Use the tapered side of lug nut.

<p>1AGAI FSAP0711</p>		<p>1AGAI FSAP072A</p>		<p>1AGAI FSAP073A</p>	
M6040	9.5-24	1420 mm	1440mm	1520 mm	
M7040	9.5-22	1510 mm	---	---	
M8540	12.4-24	1560 mm	1540mm	1660 mm	
M9540	360/70R24	1560 mm	1540mm	1660 mm	

■Rear Wheels

Rear tread width can be adjusted as shown with the standard equipped tires.

To change the tread width

1. Remove the wheel rim and / or disk mounting bolts.
2. Change the position of the rim and / or disk (right and left) to the desired position, and tighten the bolts.

IMPORTANT :

- Always attach wheels as shown in the drawing.
- If not attached as illustrated, transmission parts may be damaged.
- When re-fitting or adjusting a wheel, tighten the bolts to the following torques then recheck after driving the tractor 200m (200 yards) and thereafter according to service interval.
(See "MAINTENANCE" section.)

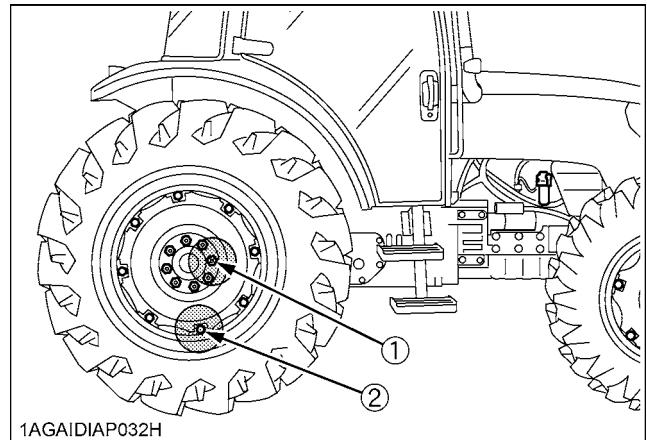

N-m (kgf-m)

	(1)	(2)
M6040, M7040	260 to 304 (26.5 to 31.0)	260 to 304 (26.5 to 31.0)
M8540, M9540	343 to 402 (35.0 to 41.0)	

Rear wheel disc		Rear wheel rim		Tread		Tread		Tread		Tread	
1AGAI DVAP043A											
M6040	16.9-28 (steel disc)	---	1420 mm	1520 mm	1620 mm	1720 mm					
M7040	16.9-30 (steel disc)										
M8540 M9540	18.4-30 (steel disc)	1540 mm	1620 mm	1740 mm	1820 mm	1940 mm					
	16.9-34 (cast iron disc)	1500 mm	1650 mm	1780 mm	1850 mm	1980 mm					
	480/70R34	1498 mm	1598 mm	1698 mm	1798 mm	1898 mm					

MAINTENANCE

SERVICE INTERVALS

No.	Items		Indication on hour meter													Interval	Ref. page			
			50	100	150	200	250	300	350	400	450	500	550	600	650				700	
[M6040, M7040]																				
1	Fan / Air-conditioner belt	Adjust		○		○		○		○		○		○		○	every 100 Hr	*		
2	Alternator belt	Adjust		○		○		○		○		○		○		○	every 100 Hr	*		
[M8540, M9540]																				
1	Fan belt	Adjust		○		○		○		○		○		○		○	every 100 Hr	*		
2	Parking brake lever	Adjust		○		○		○		○		○		○		○	every 100 Hr	28		
	Gear locked parking lever	Check		○		○		○		○		○		○		○	every 100 Hr	28		
3	Turbo charger	Check															every 3000 Hr	*	*4	
4	Intake air heater	Check															every 3000 Hr	*	*4	
5	Master cylinder filter	Clean															every 2 years	*	*4	
6	Master cylinder kit	Replace															every 2 years	*	*4	
7	Equalizer kit	Replace															every 2 years	*	*4	
8	Brake seal 1 and 2	Replace															every 2 years	*	*4	
9	Brake system	Bleed															Service as required	*	*4	
[COMMON ITEMS]																				
1	Engine start system	Check	○	○	○	○	○	○	○	○	○	○	○	○	○	○	○	every 50 Hr	*	
2	Wheel bolt torque	Check	○	○	○	○	○	○	○	○	○	○	○	○	○	○	○	every 50 Hr	*	
3	Battery condition	Check		○		○		○		○		○		○		○	every 100 Hr	*	*5	
4	Greasing	---		○		○		○		○		○		○		○	every 100 Hr	*		
5	Brake pedal	Adjust		○		○		○		○		○		○		○	every 100 Hr	*		
6	Clutch pedal [Synchro shuttle model]	Adjust	◎	○		○		○		○		○		○		○	every 100 Hr	*		

No.	Items		Indication on hour meter													Interval	Ref. page	
			50	100	150	200	250	300	350	400	450	500	550	600	650			
7	Air cleaner element	Primary element	Clean		○		○		○		○		○		○	every 100 Hr	*	*1
			Replace													every 1 year	*	*2
		Secondary element	Replace														every 1 year	*
8	Fuel line	Check		○		○		○		○		○		○	every 100 Hr	*		
		Replace														every 2 years	*	*4
9	Toe-in	Adjust				○				○				○	every 200 Hr	*		
10	Fuel tank water	Drain				○				○				○	every 200 Hr	*		
11	Intake air line	Check				○				○				○	every 200 Hr	*		
		Replace													every 2 years	*	*3	
12	Power steering oil line	Check				○				○				○	every 200 Hr	*		
		Replace													every 2 years	*	*4	
13	Radiator hose and clamp	Check				○				○				○	every 200 Hr	*		
		Replace													every 2 years	*		
14	Engine oil	Change	◎						○					○	every 300 Hr	*		
15	Hydraulic oil filter	Replace	◎						○					○	every 300 Hr	*		
16	Greasing (2WD front wheel hub)	---								○					every 400 Hr	*		
17	Water separator	Clean								○					every 400 Hr	*		
18	Fuel filter	Replace								○					every 400 Hr	*		
19	Engine oil filter	Replace	◎											○	every 600 Hr	*		
20	Transmission fluid	Change	◎											○	every 600 Hr	*		
21	Front differential case oil	Change	◎											○	every 600 Hr	*		
22	Front axle gear case oil	Change	◎											○	every 600 Hr	*		
23	Front axle pivot	Adjust												○	every 600 Hr	*		
24	Engine valve clearance	Adjust													every 800 Hr	*	*4	
25	Fuel injection nozzle injection pressure	Check													every 1500 Hr	*	*4	

No.	Items		Indication on hour meter													Interval	Ref. page			
			50	100	150	200	250	300	350	400	450	500	550	600	650				700	
26	Injection pump	Check																every 3000 Hr	*	*4
27	Cooling system	Flush																every 2 years	*	
28	Coolant	Change																every 2 years	*	
29	Lift cylinder hose	Replace																every 2 years	*	*4
30	Fuel system	Bleed																Service as required	*	
31	Clutch housing water	Drain																Service as required	*	
32	Fuse	Replace																Service as required	28	
33	Light bulb	Replace																Service as required	30	

* : See operator's manual issued separately for the sister model. [M6040, M7040, M8540, M9540]

IMPORTANT :

- The jobs indicated by © must be done after the first 50 hours of operation.
- *1 Air cleaner should be cleaned more often in dusty conditions than in normal conditions.
- *2 Every year or every 6 times of cleaning.
- *3 Replace only if necessary.
- *4 Consult your local KUBOTA Dealer for this service.
- *5 When the battery is used for less than 100 hours per year, check the battery condition by reading the indicator annually.

PERIODIC SERVICE

EVERY 100 HOURS

■ Adjusting Parking Brake Lever



CAUTION

To avoid personal injury:

- Stop the engine and chock the wheels before checking parking brake.

Proper parking brake lever free travel	3 to 5 notches (Ratchet sound 3 to 5)
--	--

1. Raise the parking brake lever to the parking position while counting the ratchet sound made by the parking brake lever.
2. If adjustment is needed, loosen the lock nut and adjust the parking brake rod length within acceptable limit.
3. Retighten the lock nut.

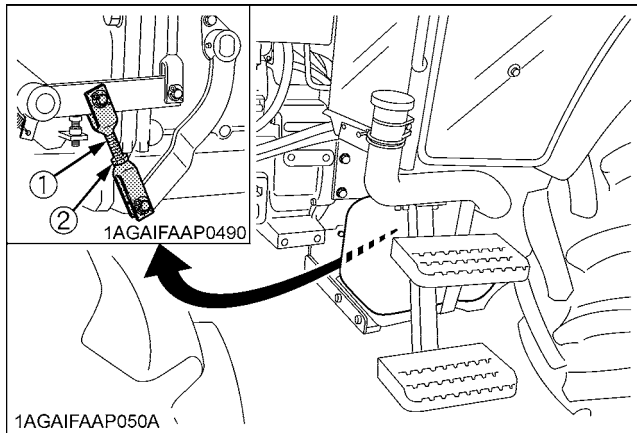

(1) Parking brake rod
(2) Lock nut

■ Checking Gear Locked Parking Lever



CAUTION

To avoid personal injury:

- Do not dismounting the tractor while checking the gear locked parking lever.

Confirm the tractor (tractor unit only) can surely be parked on the slope of about 15 degrees (Slope that rises by 2.7 meters every 10 meters).

If the tractor moves, consult your local KUBOTA Dealer. Always engage the gear locked parking lever before dismounting the tractor.

SERVICE AS REQUIRED

■ Replacing Fuse

The tractor electrical system is protected from potential damage by fuses.

A blown fuse indicates that there is an overload or short somewhere in the electrical system.

If any of the fuses should blow, replace with a new one of the same capacity.

IMPORTANT :

- Before replacing a blown fuse, determine why the fuse blew and make any necessary repairs. Failure to follow this procedure may result in serious damage to the tractor electrical system. Refer to the "TROUBLESHOOTING" section of this manual or your local KUBOTA Dealer for specific information dealing with electrical problems.

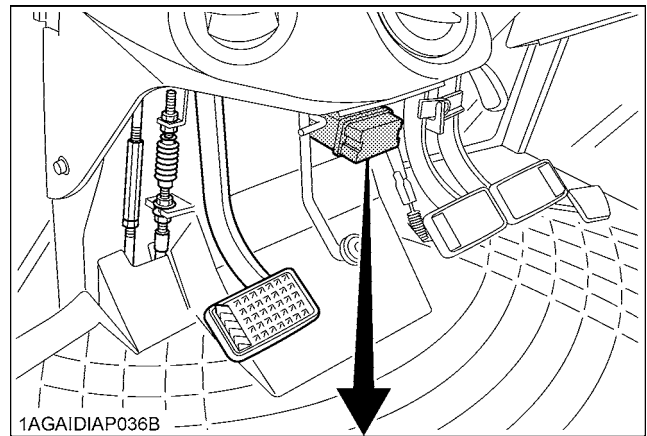

M6040
M7040

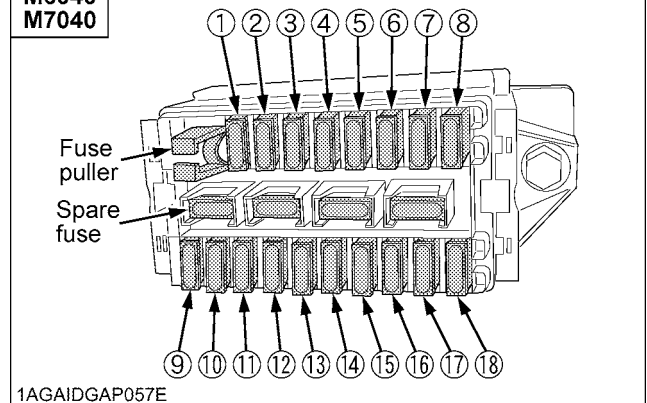

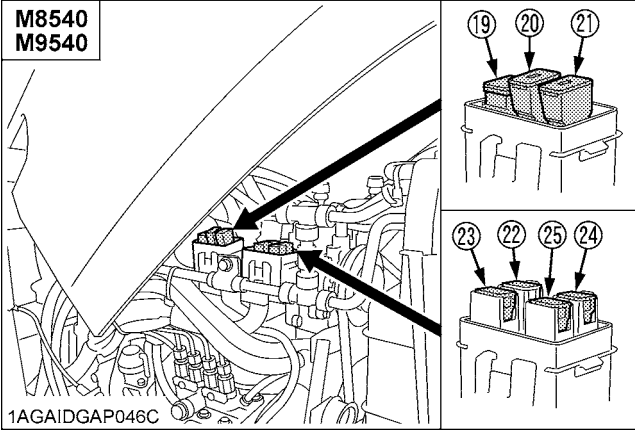
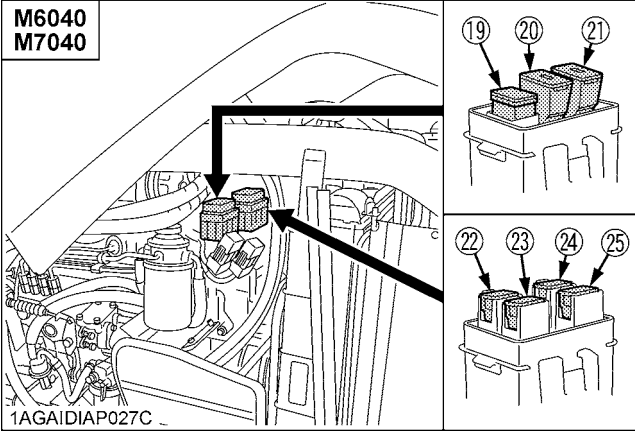
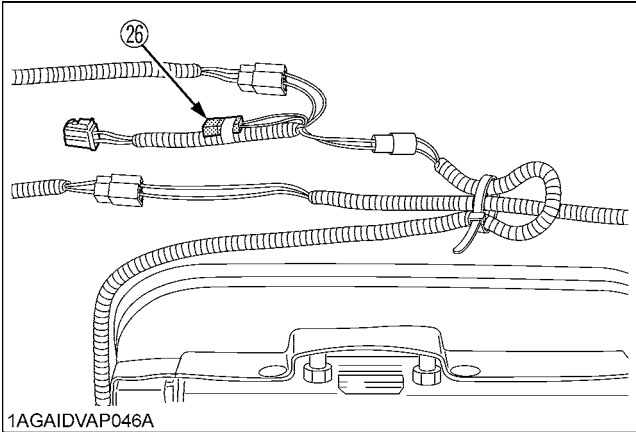
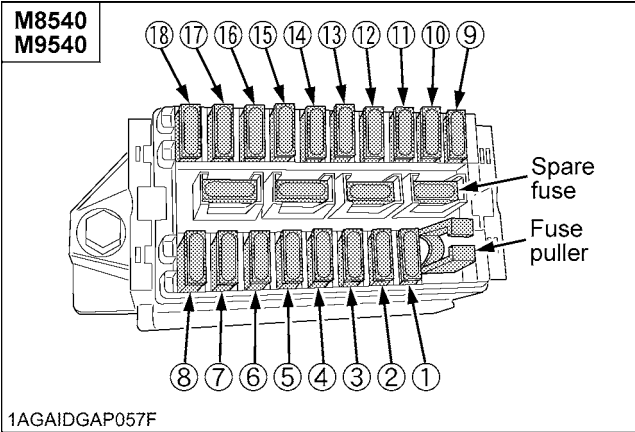

Fuse No.	Capacity (A)	Protected circuit
(1)	5	Starter Relay
(2)	15	Auxiliary Power / Air Suspension Seat (if equipped)
(3)	15	Work Light (Front, Side)
(4)	10	Air Conditioner (Compressor)
(5)	30	Air Conditioner (Fan Motor)
(6)	15	Cigarette Lighter
(7)	15	Work Light (Front)
(8)	15	Work Light (Rear)
(9)	20	Spare Fuse
(10)	20	Flasher (Hazard)
(11)	20	Head Light, Tail Lamp
(12)	10	Meter, Radio (Back Up), Horn
(13)	10	Turn Signal, Stop Lamp
(14)	5	Meter Panel, OPC
(15)	5	Alternator, Engine, Heater
(16)	15	Wiper
(17)	5	Air Conditioner (Control)
(18)	5	Radio
(19)	100	Charge
(20)	50	Air Heater
(21)	50	Head Light, Hazard
(22)	30	Work Light, Fuel Cut Solenoid
(23)	30	Key Switch
(24)	30	Electrical Outlet
(25)	40	Air Conditioner
(26)	15	Air Suspension Seat (if equipped)

■ Replacing Light Bulb

Light	Capacity
Head lights	12 V, 55 / 60 W (H4)
Turn signal / Hazard lights	12 V, 21 W
Brake stop light / Tail light	12 V, 21 / 5 W
Work light (for outer roof)	12 V, 55 W
Front work light	12 V, 21 W
Dome light (Room lamp)	12 V, 5 W

OPTIONS

Consult your local KUBOTA Dealer for further details.

- Double Acting Remote Hydraulic Control Valve with Detents and Self-Cancelling
- Flow Control Valve Kit
- Double Acting Remote Hydraulic Control Valve with Detents and Self-Cancelling for Flow Control Valve
- Double Acting Remote Hydraulic Control Valve with Float Position
- Front end weights
For front ballast
- Rear Wheel Weights
For rear ballast